

30
60

simons  VOSS

G2 Transponder

Manual

14.03.2023

Simons  Voss
technologies

Contents

1	General safety instructions	3
2	General	6
2.1	How it works	6
2.2	Incorporating the transponder in different locking systems	7
2.3	Higher-ranking locking level	8
3	Special models	10
3.1	Password transponder	10
3.2	Switch transponder.....	10
3.3	Explosion protection transponder (EX protection)	10
3.4	Bonded transponder.....	10
3.5	Transponder with integrated RFID chip	10
3.6	Fire service key tube transponder.....	11
3.7	G2 battery replacement transponder	11
4	Explosion protection transponder	12
4.1	General	12
4.2	Industrial standards	12
4.3	Classification	12
5	Additional functions	13
5.1	Time zone control	13
5.2	Date of validity.....	13
5.3	Activation transponder.....	13
6	Battery replacement	14
7	Replacing the FSR transponder battery	15
8	Loss of the transponder	18
8.1	Emergency opening.....	18
8.2	Replacement transponder [G1]	18
9	Technical data	19
9.1	Dimensions.....	20
10	Declaration of conformity	21
11	Help and other information	22

1 General safety instructions

Signal word (ANSI Z535.6)	Possible immediate effects of non-compliance
DANGER	Death or serious injury (likely)
WARNING	Death or serious injury (possible, but unlikely)
PRUDENCE	Minor injury
IMPORTANT	Property damage or malfunction
NOTE	Low or none



WARNING

Blocked access

Access through a door may stay blocked due to incorrectly fitted and/or incorrectly programmed components. SimonsVoss Technologies GmbH is not liable for the consequences of blocked access such as access to injured or endangered persons, material damage or other damage!

Blocked access through manipulation of the product

If you change the product on your own, malfunctions can occur and access through a door can be blocked.

- Modify the product only when needed and only in the manner described in the documentation.

Do not swallow battery. Danger of burns from hazardous substances

This product contains lithium button cell batteries. Swallowing the button cell battery, in can result in severe internal burns leading to death in as little as two hours.

1. Keep new and used batteries away from children.
2. If the battery compartment does not close securely, cease using the product and keep it away from children.
3. If you think batteries have been swallowed or are in any part of the body, seek medical attention immediately.

Risk of explosion due to incorrect battery type

Inserting the wrong type of battery can cause an explosion.

- Only use the batteries specified in the technical data.

**PRUDENCE****Fire hazard posed by batteries**

The batteries used may pose a fire or burn hazard if handled incorrectly.

1. Do not try to charge, open, heat or burn the batteries.
2. Do not short-circuit the batteries.

IMPORTANT**Damage resulting from electrostatic discharge (ESD)**

This product contains electronic components that may be damaged by electrostatic discharges.

1. Use ESD-compliant working materials (e.g. Grounding strap).
2. Ground yourself before carrying out any work that could bring you into contact with the electronics. For this purpose, touch earthed metallic surfaces (e.g. door frames, water pipes or heating valves).

Damage resulting from liquids

This product contains electronic and/or mechanic components that may be damaged by liquids of any kind.

- ❑ Keep liquids away from the electronics.

Damage resulting from aggressive cleaning agents

The surface of this product may be damaged as a result of the use of unsuitable cleaning agents.

- ❑ Only use cleaning agents that are suitable for plastic or metal surfaces.

Damage as a result of mechanical impact

This product contains electronic components that may be damaged by mechanical impacts of any kind.

1. Avoid touching the electronics.
2. Avoid other mechanical influences on the electronics.

Damage due to polarity reversal

This product contains electronic components that may be damaged by reverse polarity of the power source.

- ❑ Do not reverse the polarity of the voltage source (batteries or mains adapters).

Operational malfunction due to radio interference

This product may be affected by electromagnetic or magnetic interference.

- ❑ Do not mount or place the product directly next to devices that could cause electromagnetic or magnetic interference (switching power supplies!).

Communication interference due to metallic surfaces

This product communicates wirelessly. Metallic surfaces can greatly reduce the range of the product.

- ❑ Do not mount or place the product on or near metallic surfaces.



NOTE

Intended use

SimonsVoss-products are designed exclusively for opening and closing doors and similar objects.

- ❑ Do not use SimonsVoss products for any other purposes.

Malfunctions due to poor contact or different discharge

Contact surfaces that are too small/contaminated or different discharged batteries can lead to malfunctions.

1. Only use batteries that are approved by SimonsVoss.
2. Do not touch the contacts of the new batteries with your hands.
3. Use clean and grease-free gloves.
4. Always replace all batteries at the same time.

Different times for G2 locks

The internal time unit of the G2 locks has a technical tolerance of up to ± 15 minutes per year.

Qualifications required

The installation and commissioning requires specialized knowledge.

- ❑ Only trained personnel may install and commission the product.

Incorrect installation

SimonsVoss Technologies GmbH accepts no liability for damage caused to doors or components due to incorrect fitting or installation.

Modifications or further technical developments cannot be excluded and may be implemented without notice.

The German language version is the original instruction manual. Other languages (drafting in the contract language) are translations of the original instructions.

Read and follow all installation, installation, and commissioning instructions. Pass these instructions and any maintenance instructions to the user.

2 General



Transponder 3064 is a digital "key" which is programmed with locking plan software and functions using contactless, wireless communication. All functions are activated by pressing a button. These include authorisation identification and the opening and locking of doors, gates, barriers, furniture locks and similar items. The transponder communicates with digital components – cylinders, SmartRelays and activation units – by sending and receiving constantly changing crypto codes, which ensure that the system cannot be misused.

As System 3060 functions using active transponder technology, the transponder features its own power source, a battery. Advantages over passive technologies include lower power requirements in the cylinder and the greater operating range.

SimonsVoss supplies different transponder models. These models are described in this document.

The second transponder generation G2 replaces the first generation G1. G2 features a more efficient communication protocol than G1. It will allow you to create larger, more efficient locking systems. Authorisations are also written on both the locking cylinder and the transponder, making programming more flexible.

A G2 system can also form a virtual network, i.e. authorisations and blocking lists are written on the transponder and transmitted to the locking system.

This manual looks at the specific differences between transponders. Read the G2 manual for more details.

The G2 transponder features both the G1 and G2 protocols and can thus be programmed for both locking system generations.

2.1 How it works

To carry out an action, the user holds the transponder close to the digital lock and presses the transponder button.

Refer to the recommended distances:

Digital Cylinder AX	5 cm to 20 cm
Locking Cylinder 3061	15 cm to 40 cm
SmartHandle AX	5 cm to 30 cm
SmartHandle 3062	5 cm to 40 cm
SmartLocker AX	5 cm to 30 cm
Padlock AX	5 cm to 20 cm
Padlock	15 cm to 40 cm
SmartRelais 3 Advanced	5 cm to 100 cm
SmartRelais 2.G2	5 cm to 120 cm

The transponder and locking device then exchange keys and authorisation data. The user can only perform the required action, such as opening or locking the door, if the transponder is authorised for the digital lock.

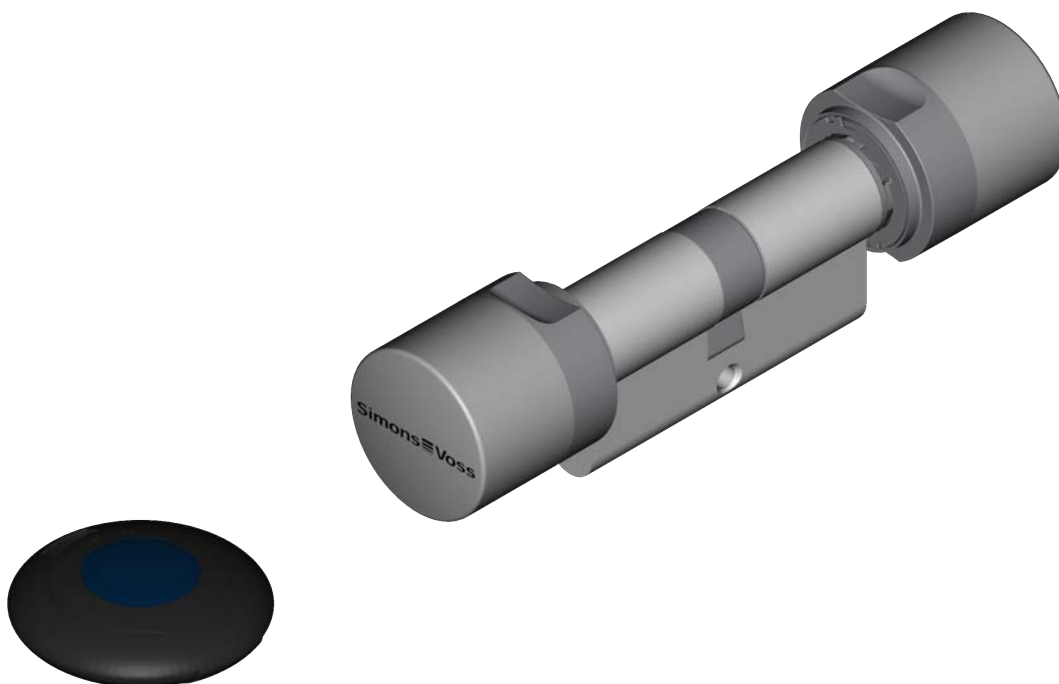

2.2 Incorporating the transponder in different locking systems

Each transponder can be used in three [G1] or four [G2] completely separate locking systems, providing no areas of validity are programmed. Each locking system receives its own password and is managed separately. The following screen shows an example of use.

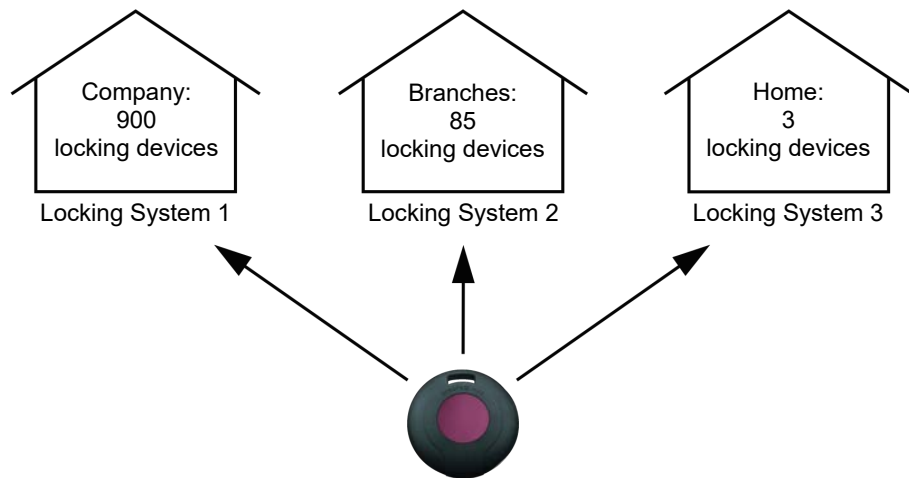

Fig. 1: A transponder for several separate locking systems

2.3 Higher-ranking locking level

Transponders can be authorised for more than three [G1] or four [G2] locking systems. To ensure this is the case, higher-ranking locking levels need to be set up in the locking systems concerned. A maximum of three higher-ranking locking levels can be set up per locking system (green, blue and red).



PRUDENCE

Opening deactivated locking devices using the red level

Transponders which have been assigned to the red locking level can also open deactivated locking devices using a block lock function.

- Assign the red locking level to emergency services such as the fire service only.



NOTE

Reprogramming a higher-ranking locking level

Higher-ranking locking levels can only be programmed directly on the locking device.

200 [G1] or 1024 [G2] transponder IDs (TIDs) are reserved for each level in LSM. Authorisations for different transponders in the higher-ranking locking levels may be different.

The following screen shows an example of use.

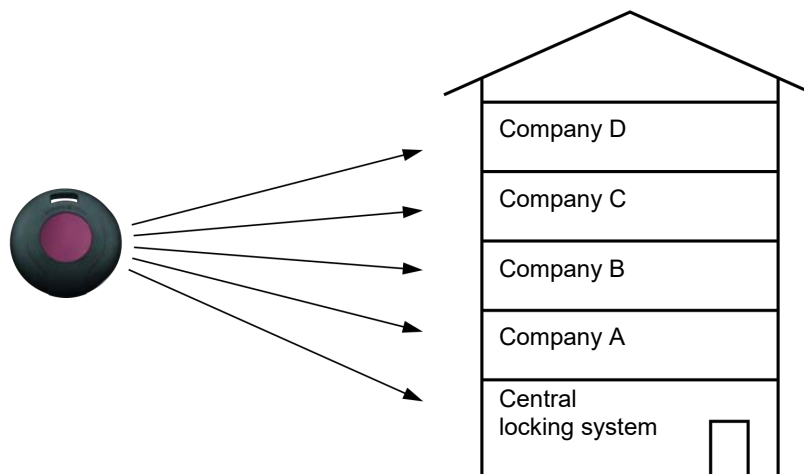

Fig. 2: Higher-ranking transponder

Four companies are based in an office building with a main lock which is used by all the companies. Each company manages its own locking system with its own password. Each employee receives a transponder which is authorised for two locking systems, the main lock and their company's own system. The building management or on-site technicians and cleaning staff require access to all levels. The fire service, for example, requires a transponder which is valid for all five locking systems in the building. They also require access if the alarm system is activated and the block lock function has disabled the locking cylinders. Higher-ranking locking levels are created in each of the five locking systems to provide access to all five locking systems. Each level receives the same password for all locking systems.

3 Special models

3.1 Password transponder

Instead of being entered manually, the locking system password can be transmitted by radio using a special transponder. Standard transponders cannot be used as a password transponder.

3.2 Switch transponder

For this type of transponder, a two-wire cable (about 1 m long) is connected to the switch contacts on the button and fed to the outside. When the two wires are connected, the transponder interconnects and is able to trigger actions.

Examples of use:

- Linking third-party systems
- Remote activation of a digital locking cylinder or SmartRelay

3.3 Explosion protection transponder (EX protection)

This transponder has the same functions as a Transponder 3064, but it is also approved for use in Explosion Protection Zone 1 (see *Explosion protection transponder* [▶ 12]).

3.4 Bonded transponder

This transponder is almost identical to the standard transponder, but has a bonded casing. This prevents the end user from misusing the transponder electronics or opening the casing.

3.5 Transponder with integrated RFID chip

Transponders can be supplied with different integrated RFID chips as an option. These RFID Chips do not necessarily need to be programmed with the LSM software. The active transponder and passive RFID part are independent from one another.

The following different RFID technologies are available:

- EM® 4102
- HITAG® 1
- HITAG® 2
- MIFARE® Classic
- MIFARE® DESFire
- LEGIC® MIM 256

■ LEGIC® advant 128

3.6 Fire service key tube transponder

Almost identical to the standard transponder, but has a narrower casing (33 mm) and can be kept in a standardised fire service key tube.

3.7 G2 battery replacement transponder

A G2 battery replacement transponder can be created in the LSM software (Version 3.0 or higher) for G2 locking systems. If the battery is low, the locking device will switch to freeze mode and can no longer be opened with normal transponders. The battery replacement transponder can eliminate freeze mode when activated on the cylinder. The locking device can then be opened with an authorised transponder. This means you no longer need to take the programming device to enable the locking device.



PRUDENCE

Depleting batteries through misuse

The battery is depleted further each time it opens a locking device in conjunction with a battery replacement transponder. This may lead to the batteries being fully discharged if the transponder is not used for its intended purpose! The batteries must be replaced immediately in such cases.

4 Explosion protection transponder

4.1 General

This transponder is a special product which can be carried and used in Zone 1 potentially explosive areas. Zone 1 refers to an area where a potentially explosive atmosphere sometimes occurs during day-to-day operations. The following aspects must be taken into account:

- The casing must not be opened.
- Unlike with Standard Transponders 3064, only SimonsVoss may change the battery in this transponder.
- As a general rule, users must comply with explosion protection regulations such as the German Operating Regulations BGR132 when using the device in Zone 1.

4.2 Industrial standards

This transponder has been tested in accordance with applicable explosion protection standards.

Refer to the following for further information:

- Directive 94/9/EC
- EN 60079-0 (Equipment for explosive atmospheres)
- EN 60079-11 (Equipment protection by intrinsic safety "i!")

4.3 Classification

The transponder is classified as follows:

Explosion Protection Zone	1
Intrinsic safety	ib
Explosion group	IIC
Temperature class	T3
Device group	II2 G

This applies to areas where a potentially explosive atmosphere may occur due to gases, vapours or mist. The information given refers to an ambient temperature between -20°C and +40°C in the area of use.

5 Additional functions

The functions described below can be activated in the LSM software.

5.1 Time zone control

Transponders can be programmed to have locking authorisation for digital access control locking devices at certain times only (time zones). Such time zones are added to the LSM software and the transponders are then allocated to the relevant time zone group.

Example: Mr Smith receives the following authorisations:

Monday to Friday	Between 09:00 and 18:30
Saturday	Between 09:00 and 12:45
Sunday	No authorisation

5.2 Date of validity

Transponder authorisations can be linked to a validity date. The locking device does not need to be an access control locking device.

- Transponders which are valid **from** a specific point in time
(e.g. from 08:00 on July 12, 2005)
- Transponders which are valid **until** a specific point in time
(e.g. until 17:00 on July 12, 2005)
- Transponders which are valid **for** a specific time period
(e.g. between 1 July, 2003 until 31 July, 2005)



NOTE

Data record creation

A data record is created each time for the activation or expiry date.

5.3 Activation transponder

As the result of a Block Lock function, all authorised transponders are blocked for digital locking devices in a safety area when the alarm system is activated to prevent false alarms.

Transponders can be programmed which eliminate this blocking mode and can then be used in an emergency by the fire service, for example (see *Higher-ranking locking level* [▶ 8]). The door can then only be opened using an authorised transponder.

6 Battery replacement

The transponder battery can be replaced at any time.



WARNING

Risk of explosion due to incorrect battery replacement

A battery fitted incorrectly into an explosion protection transponder may ignite an explosive atmosphere. Therefore, only SimonsVoss Technologies GmbH may replace the battery in explosion protection transponders.



PRUDENCE

Lack of power supply on battery replacement

The transponder may lose data due to the interruption in power supply. Do not interrupt the power supply for longer than two minutes. Do not press the button when there is no power and avoid short circuits.

7 Replacing the FSR transponder battery

Replace the battery on a yearly basis.



NOTE

Need for programming following a short circuit

Short-circuits can make reprogramming necessary.

1. Avoid short circuits during battery replacement.
2. If necessary, reprogram the transponder.



NOTE

Shorter battery life due to poor contact

Skin oil impairs contact between the battery and the battery holder.

1. Do not touch the contacts on new batteries with your hands when replacing old ones.
2. Use clean cotton gloves free of fat or grease.



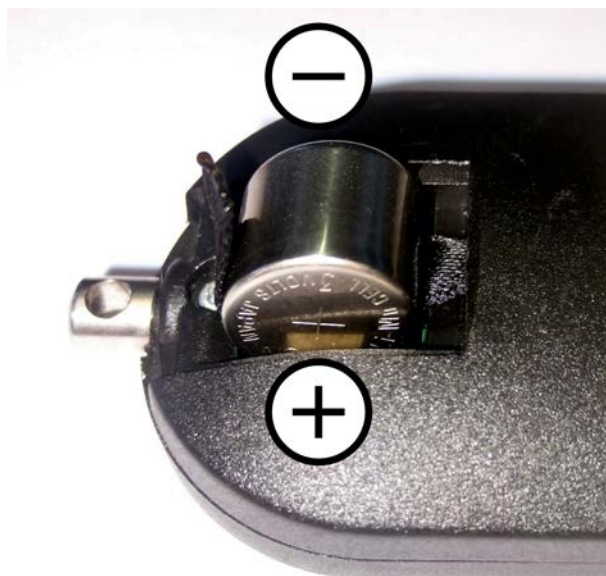



8 Loss of the transponder

8.1 Emergency opening

You may carry out an emergency opening with the SmartCD and PDA and by entering the locking system password.

8.2 Replacement transponder [G1]

If a transponder is lost, it can be blocked in the locking plan and a replacement transponder added. If the locking system is operated in overlay mode [G1], the transponder is automatically disabled as soon as the replacement transponder is activated on the locking device (see LSM manual for programming).

9 Technical data

Housing	Material	Weatherproof plastic (polyamide)
	Colours	Casing: black
		Buttons: different colours
	Diameter	42.0 mm
	Height	13.7 mm
Ambient conditions	Temperature range	-20 °C to 60 °C
	Standard protection rating	IP65
		IP66 (.SPEZ version)
Environmental Class	III	
Batteries	Type	CR2032
	Manufacturer	Varta, Panasonic, Murata
	Quantity	1x
	Voltage	3 V
	Battery life	Up to 400,000 activations or up to 10 years on standby
Range	Digital Cylinder AX	5 cm to 20 cm
	Locking Cylinder 3061	15 cm to 40 cm
	SmartHandle AX	5 cm to 30 cm
	SmartHandle 3062	5 cm to 40 cm
	SmartLocker AX	5 cm to 30 cm
	Padlock AX	5 cm to 20 cm
	Padlock	15 cm to 40 cm
	SmartRelais 3 Advanced	5 cm to 100 cm
	SmartRelais 2.G2	5 cm to 120 cm

Radio emissions

24.50 kHz - 25.06 kHz	-20 dB μ A/m (10 m distance)
-----------------------	----------------------------------

13.564 MHz - 13.564 MHz Only for item numbers: TRA2.G2.*RFID*	
---------------------------------------------------------------------	--

9.1 Dimensions

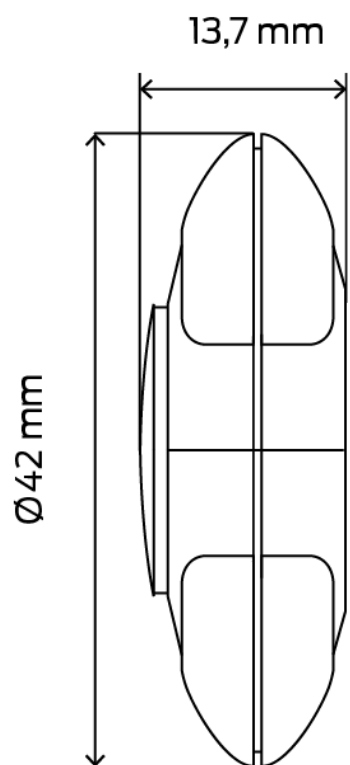

10 Declaration of conformity

The company SimonsVoss Technologies GmbH hereby declares that the articles (TRA2.G2.*, TRA2.G2.*RFID*) comply with the following guidelines:

- 2014/53/EU -RED-
or for the UK: UK statutory 2017 No. 1206 -Radio equipment-
- 2011/65/EU -RoHS-
or for the UK: UK statutory 2012 No. 3032 -RoHS-



The full text of the EU Declaration of conformity is available at the following internet address: <https://www.simons-voss.com/en/certificates.html>.
The full text of the UK Declaration of conformity is available at the following internet address: <https://www.simons-voss.com/en/certificates.html>.

11 Help and other information

Information material/documents

You will find detailed information on operation and configuration and other documents on the website:

<https://www.simons-voss.com/en/documents.html>

Declarations of conformity

You will find declarations of conformity and other certificates on the website:

<https://www.simons-voss.com/en/certificates.html>

Information on disposal

- Do not dispose the device (TRA2.G2.*, TRA2.G2.*RFID*) in the household waste. Dispose of it at a collection point for electronic waste as per European Directive 2012/19/EU.
- Recycle defective or used batteries in line with European Directive 2006/66/EC.
- Observe local regulations on separate disposal of batteries.
- Take the packaging to an environmentally responsible recycling point.



Technical support

Our technical support will be happy to help you (landline, costs depend on provider):

+49 (0) 89 / 99 228 333

Email

You may prefer to send us an email.

support-simonsvoss@allegion.com

FAQs

You will find information and help in the FAQ section:

<https://faq.simons-voss.com/otrs/public.pl>

Address

SimonsVoss Technologies GmbH
Feringastr. 4
D-85774 Unterfoehring
Germany



This is SimonsVoss

SimonsVoss, the pioneer in remote-controlled, cable-free locking technology provides system solutions with a wide range of products for SOHOs, SMEs, major companies and public institutions. SimonsVoss locking systems combine intelligent functionality, high quality and award-winning design Made in Germany.

As an innovative system provider, SimonsVoss focuses on scalable systems, high security, reliable components, powerful software and simple operation. As such, SimonsVoss is regarded as a technology leader in digital locking systems.

Our commercial success lies in the courage to innovate, sustainable thinking and action, and heartfelt appreciation of employees and partners.

SimonsVoss is a company in the ALLEGION Group, a globally active network in the security sector. Allegion is represented in around 130 countries worldwide (www.allegion.com).

Made in Germany

SimonsVoss is truly committed to Germany as a manufacturing location: all products are developed and produced exclusively in Germany.

© 2023, SimonsVoss Technologies GmbH, Unterföhring

All rights are reserved. Text, images and diagrams are protected under copyright law.

The content of this document must not be copied, distributed or modified. More information about this product can be found on the SimonsVoss website. Subject to technical changes.

SimonsVoss and MobileKey are registered brands belonging to SimonsVoss Technologies GmbH.

SimonsVoss
technologies

Made in Germany

A BRAND OF

ALLEGION™