

30
60

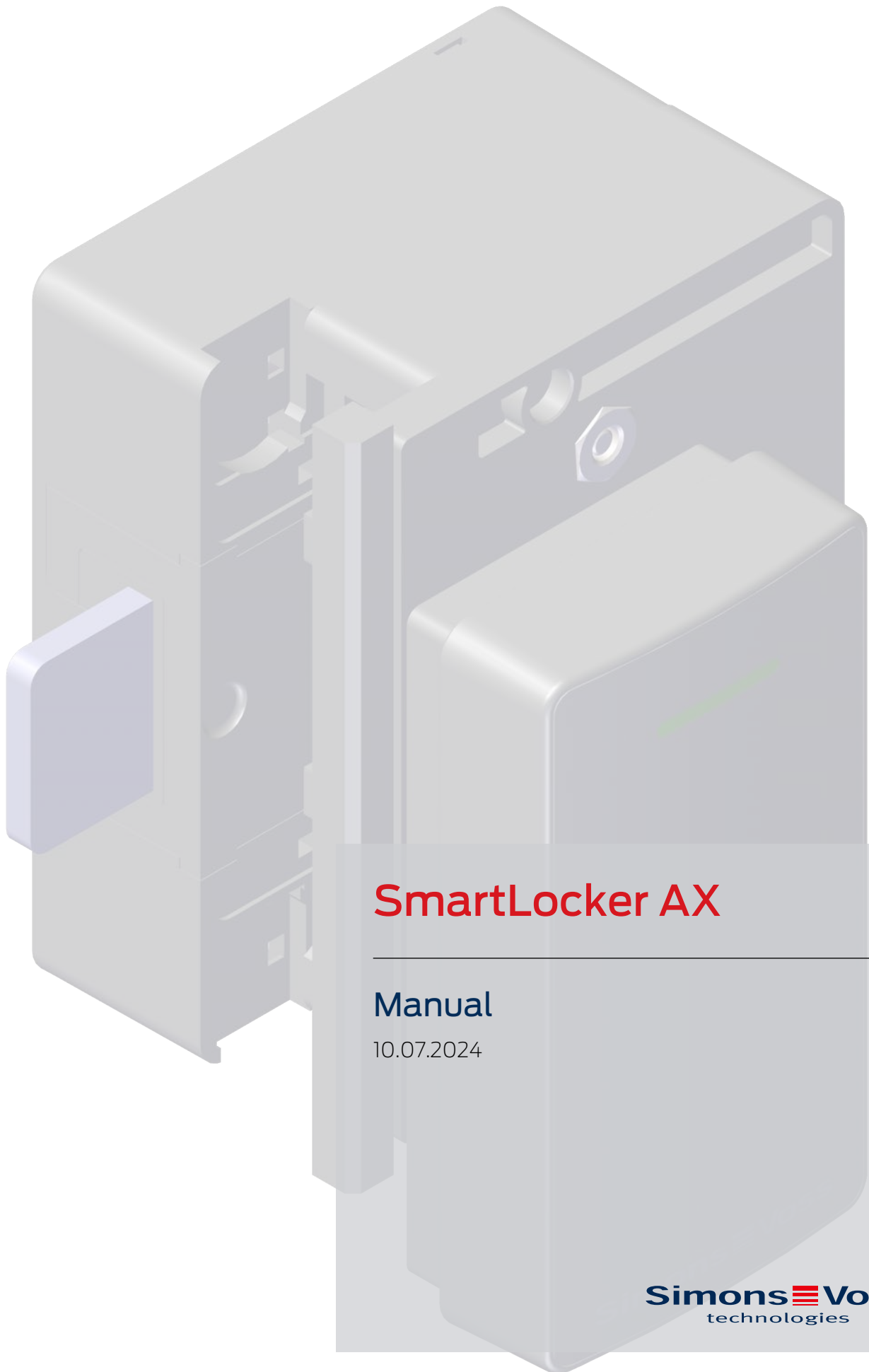

SmartLocker AX

Manual

10.07.2024

Simons  Voss
technologies

Contents

1.	Intended use.....	3
2.	General safety instructions	4
3.	Scope of delivery	7
4.	Exploded view.....	8
5.	Initial operation	9
5.1	Programming.....	9
5.2	Measurement and calculation.....	10
5.3	Installation	11
6.	Subsequent fixation on wooden doors.....	26
7.	Operation	27
8.	LockNode	28
8.1	Intended use	28
8.2	Installation	28
9.	Battery change	40
9.1	Emergency power supply	42
10.	Signalisation.....	43
11.	Disassembly	44
12.	Technical specifications.....	45
12.1	Dimensional drawings.....	46
12.2	Drawings of installation situations.....	48
13.	Declaration of conformity.....	52
14.	Help and other information	53

1. Intended use

SmartLocker AX allows you to manage and control your cabinets and lockers conveniently and efficiently. You can programme directly from your workstation or carry out remote opening via the optional radio link. SmartLocker AX is operated with passive identification media, active transponders or both.

2. General safety instructions

Signal word: Possible immediate effects of non-compliance

WARNING: Death or serious injury (possible, but unlikely)

CAUTION: Minor injury

IMPORTANT: Property damage or malfunction

NOTE: Low or none



WARNING

Blocked access

Access through a door may stay blocked due to incorrectly fitted and/or incorrectly programmed components. SimonsVoss Technologies GmbH is not liable for the consequences of blocked access such as access to injured or endangered persons, material damage or other damage!

Blocked access through manipulation of the product

If you change the product on your own, malfunctions can occur and access through a door can be blocked.

- ❑ Modify the product only when needed and only in the manner described in the documentation.



CAUTION

Fire hazard posed by batteries

The batteries used may pose a fire or burn hazard if handled incorrectly.

1. Do not try to charge, open, heat or burn the batteries.
2. Do not short-circuit the batteries.

IMPORTANT

Damage resulting from electrostatic discharge (ESD) when enclosure is open

This product contains electronic components that may be damaged by electrostatic discharges.

1. Use ESD-compliant working materials (e.g. Grounding strap).
2. Ground yourself before carrying out any work that could bring you into contact with the electronics. For this purpose, touch earthed metallic surfaces (e.g. door frames, water pipes or heating valves).

Damage resulting from liquids

This product contains electronic and/or mechanic components that may be damaged by liquids of any kind.

- ❑ Keep liquids away from the electronics.

Damage resulting from aggressive cleaning agents

The surface of this product may be damaged as a result of the use of unsuitable cleaning agents.

- ❑ Only use cleaning agents that are suitable for plastic or metal surfaces.

Damage as a result of mechanical impact

This product contains electronic components that may be damaged by mechanical impacts of any kind.

1. Avoid touching the electronics.
2. Avoid other mechanical influences on the electronics.

Damage due to polarity reversal

This product contains electronic components that may be damaged by reverse polarity of the power source.

- ❑ Do not reverse the polarity of the voltage source (batteries or mains adapters).

Operational malfunction due to radio interference

This product may be affected by electromagnetic or magnetic interference.

- ❑ Do not mount or place the product directly next to devices that could cause electromagnetic or magnetic interference (switching power supplies!).



NOTE

Intended use

SimonsVoss-products are designed exclusively for opening and closing doors and similar objects.

- ❑ Do not use SimonsVoss products for any other purposes.

Malfunctions due to poor contact or different discharge

Contact surfaces that are too small/contaminated or different discharged batteries can lead to malfunctions.

1. Only use batteries that are approved by SimonsVoss.
2. Do not touch the contacts of the new batteries with your hands.
3. Use clean and grease-free gloves.
4. Always replace all batteries at the same time.

Different times for G2 locks

The internal time unit of the G2 locks has a technical tolerance of up to ± 15 minutes per year.

- ❑ Regularly reprogram time-critical locking devices.

Qualifications required

The installation and commissioning requires specialized knowledge.

- ❑ Only trained personnel may install and commission the product.

Incorrect installation

SimonsVoss Technologies GmbH accepts no liability for damage caused to doors or components due to incorrect fitting or installation.

Modifications or further technical developments cannot be excluded and may be implemented without notice.

The German language version is the original instruction manual. Other languages (drafting in the contract language) are translations of the original instructions.

Read and follow all installation, installation, and commissioning instructions. Pass these instructions and any maintenance instructions to the user.

3. Scope of delivery

- Reader
- Motor block
- Connection socket
- 3 adapter plates (can be reordered: LL.PLATE5)
- Adapter plate with positioning guide (can be reordered: LL.PLATEVAR)
- 2 flange extensions (can be re-ordered)
- M4 screws with round head (16 mm, 20 mm, 25 mm)
- M4 hex nut
- Tensioning element with tapping screw
- 4 bolt blocks (one of which is pre-fitted)
- 2 fastening pieces for wooden doors
- 0.9 mm hex wrench
- Fastening tool for M4 screws
- Tool for ribbon cable connectors
- Quick guide

The reader unit also contains two spare screws for the cover lock ex works.

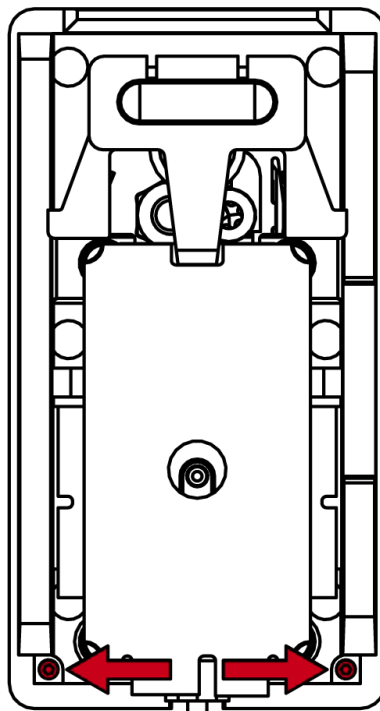

4. Exploded view

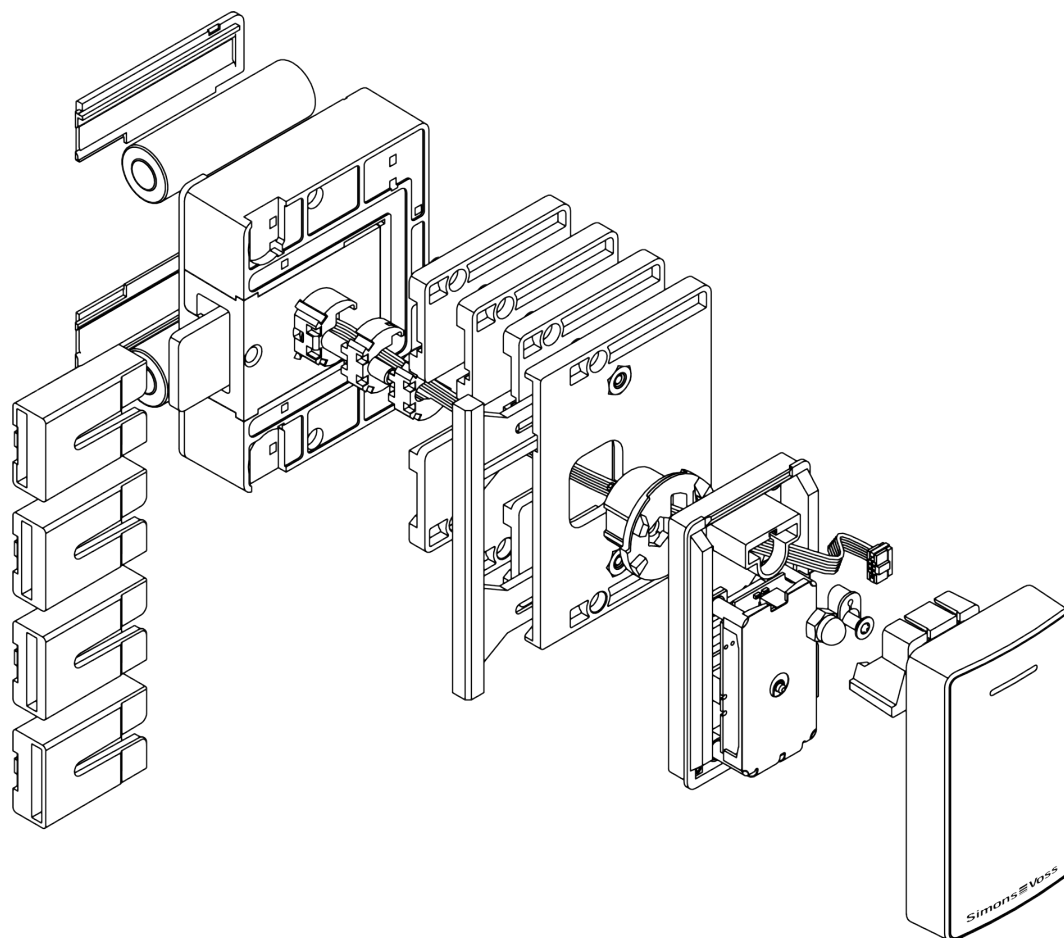

5. Initial operation

5.1 Programming

✓ LSM open.

1. Click  to open the window "New lock".

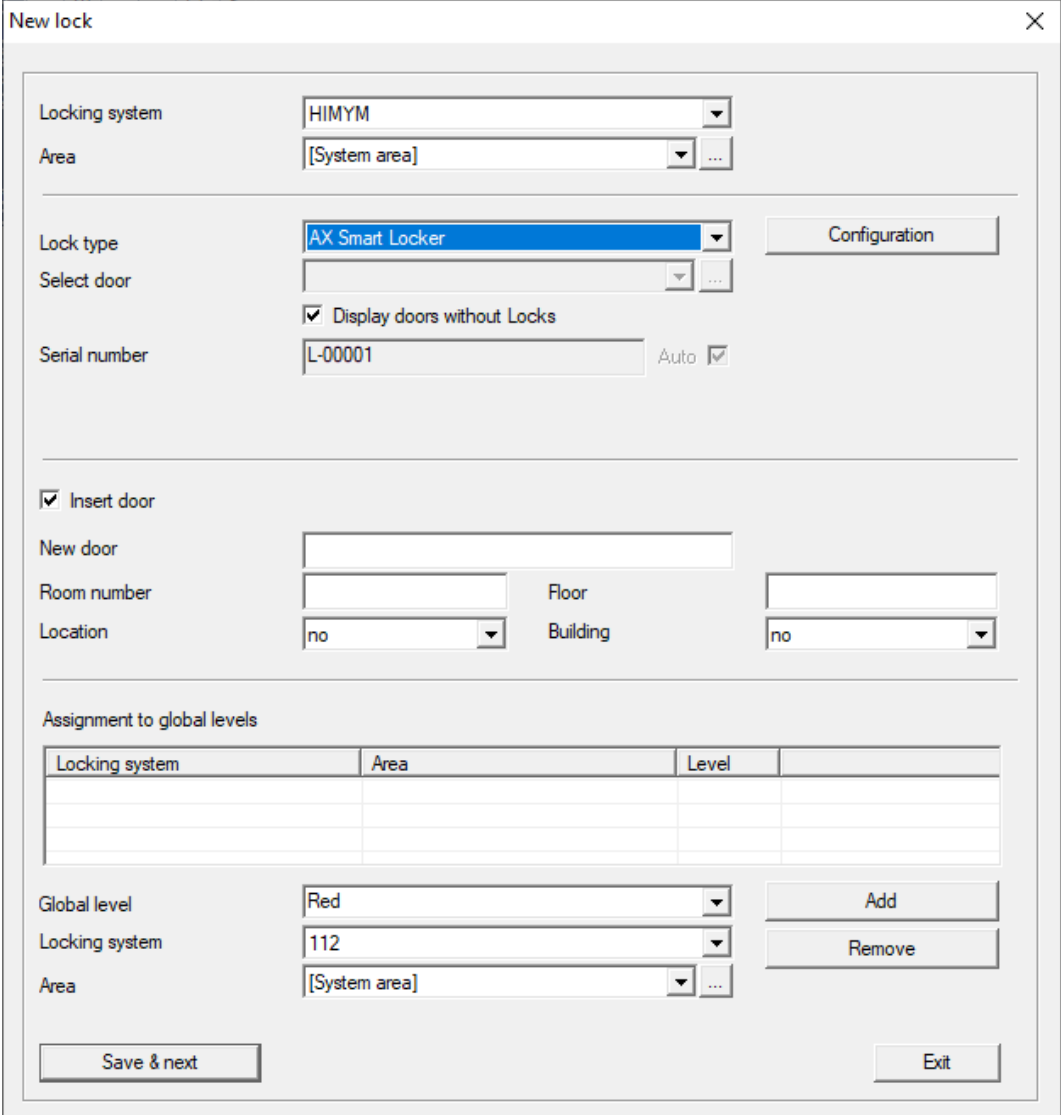

New lock

Locking system: HIMYM
Area: [System area]

Lock type: AX Smart Locker
Select door: []
 Display doors without Locks

Serial number: L-00001 Auto

Insert door

New door: []
Room number: [] Floor: []
Location: no Building: no

Assignment to global levels

Locking system	Area	Level	

Global level: Red
Locking system: 112
Area: [System area]

Buttons: Configuration, Add, Remove, Save & next, Exit

2. Use ▼ Lock type to select "AX SmartLocker".

3. Program the SmartLocker AX.

↳ SmartLocker AX is programmed.

5.2 Measurement and calculation

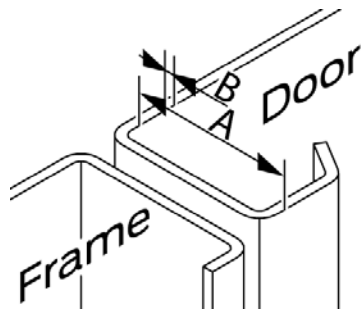

1. Measure the distance between the inside of the door and the dead-bolt stop (A), e.g. with the depth rod of a caliper gauge.

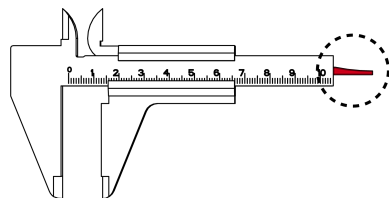

2. Measure the thickness of the door/door panel (B).
3. Refer to the tables for the parts required from the scope of delivery (adapter plates, dead-bolt fixture, flange extensions and screw). Additional parts can be ordered (see manual).

Inner side of door up to dead-bolt stop (A)	Adapter plate P (LL.PLATE5)	Dead-bolt fixture R
0.0 mm to 5.95 mm	None	4 (5.9 mm)
6.05 mm to 7.25 mm	None	3 (7.5 mm)
7.35 mm to 8.85 mm	None	2 (9.1 mm)
8.95 mm to 10.45 mm	None	1 (10.4 mm)
10.55 mm to 10.95 mm	5 mm	4 (5.9 mm)
11.05 mm to 12.25 mm	5 mm	3 (7.5 mm)
12.35 mm to 13.85 mm	5 mm	2 (9.1 mm)
13.95 mm to 15.45 mm	5 mm	1 (10.4 mm)
15.55 mm to 15.95 mm	2 × 5 mm	4 (5.9 mm)
16.05 mm to 17.25 mm	2 × 5 mm	3 (7.5 mm)
17.35 mm to 18.85 mm	2 × 5 mm	2 (9.1 mm)
18.95 mm to 20.45 mm	2 × 5 mm	1 (10.4 mm)
20.55 mm to 20.95 mm	3 × 5 mm	4 (5.9 mm)
21.05 mm to 22.25 mm	3 × 5 mm	3 (7.5 mm)

Inner side of door up to dead-bolt stop (A)	Adapter plate P (LL.PLATE5)	Dead-bolt fixture R
22.35 mm to 23.85 mm	3 × 5 mm	2 (9.1 mm)
23.95 mm to 25.45 mm	3 × 5 mm	1 (10.4 mm)

Dead-bolt fixtures are numbered:

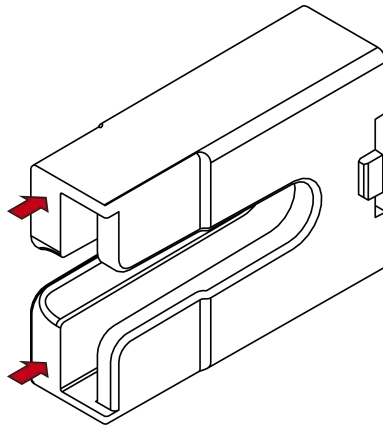

Door/door panel thickness B+ adapter plates P	Flange extensions F	Screw
10 mm to 16.0 mm	None	M4×16 mm
16.1 mm to 19.0 mm	1×	M4×20 mm
19.1 mm to 25.0 mm	2×	M4×25 mm
25.1 mm to 30 mm	3×	M4×30 mm

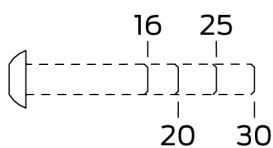

5.3 Installation

The adapter plates are not used for wooden doors. Use the supplied fastening pieces.

You will need the following tools:

- 0.9 mm hex wrench (included)
- Electronics needle-nosed pliers
- PH1 screwdriver
- Slotted screwdriver (if the dead-bolt block needs to be replaced)
- 2.5 mm hex wrench
- TX10 screwdriver

- ✓ SmartLocker AX locked ex works = dead bolt extended, programme if necessary (see *Programming* [▶ 9]).
 - ✓ Door and parts calculated (see *Measurement and calculation* [▶ 10]).
1. Insert the 0.9 mm hex key into the lower screw.

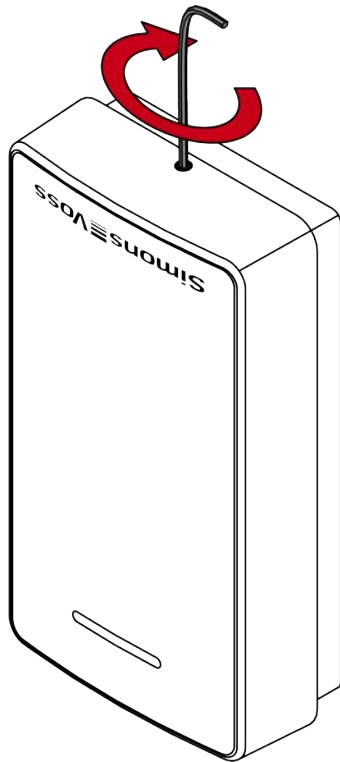

2. Gently press the reader cover against the floor and turn the lower screw clockwise inwards until you can lift off the cover.

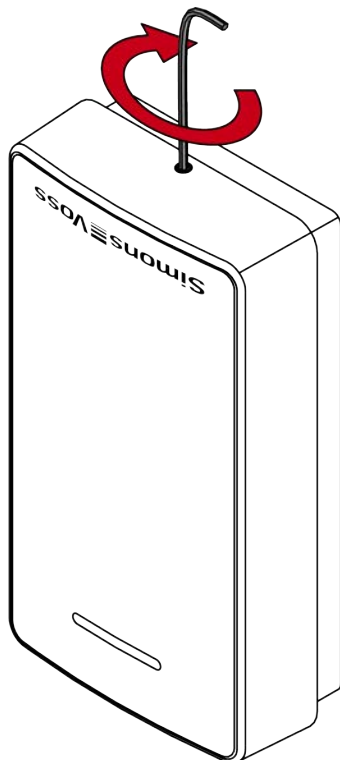

3. Remove the cover.

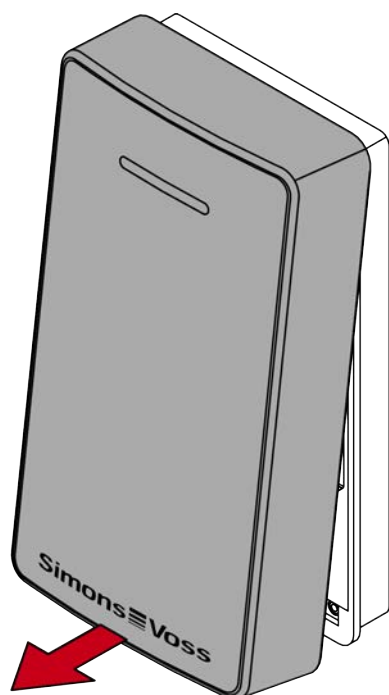

4. Using needle-nosed pliers, disconnect the plug of the cable below the circuit board.
5. Disassemble the reader and engine block.
6. Insert the socket into the D-hole (mount for nut pointing towards the edge of the door).

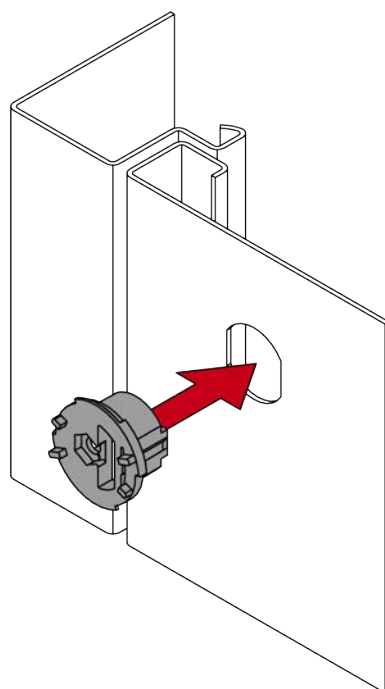

7. Insert the adapter plate with the parallel forced guide onto the socket from the rear.

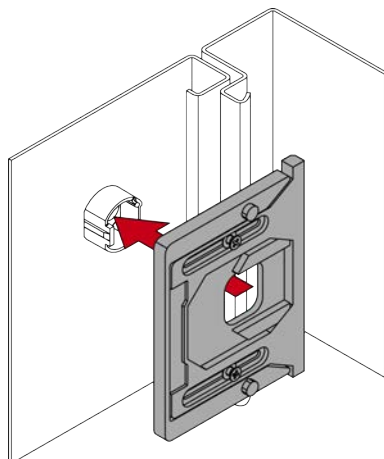

8. Slide the forced guide out until it rests against the inner edge of the door.

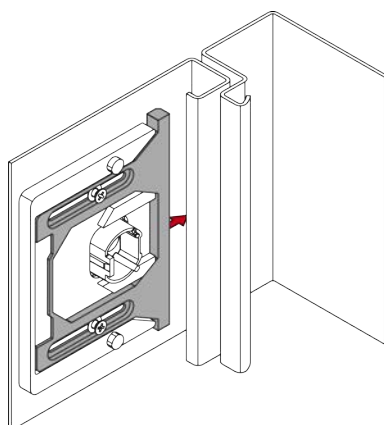

9. Continue to press the forced guide against the inner edge and screw the screws tight with approx. 20 Ncm (PH1 screwdriver) until the forced guide can no longer be moved.

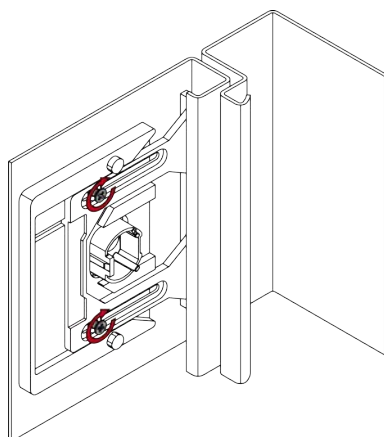

10. If necessary, insert additional adapter plates into the socket.

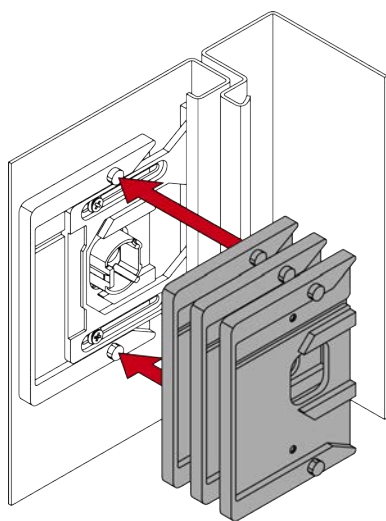

11. If necessary, lever the dead-bolt block out of the engine block using a slotted screwdriver.

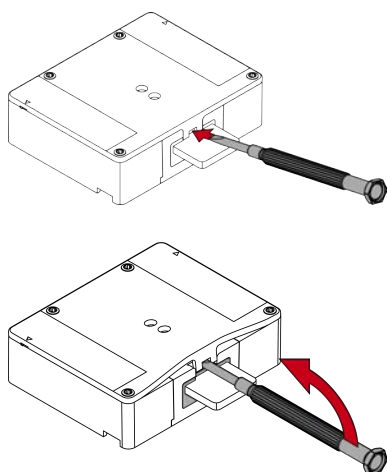

12. If necessary, insert another dead-bolt block into the engine block.

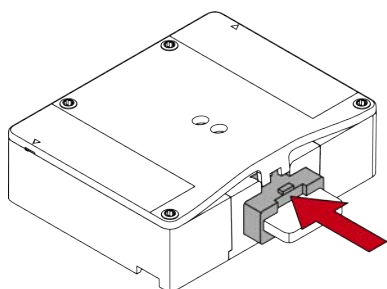

13. Hook the screw into the holder and hold it in place.

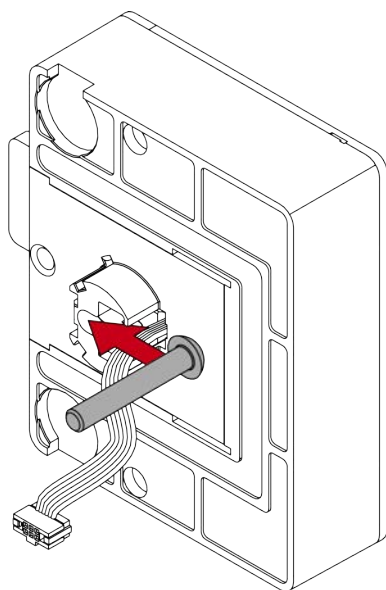

14. Fix the screw through the dead-bolt side hole on the back with the plastic mounting tool.

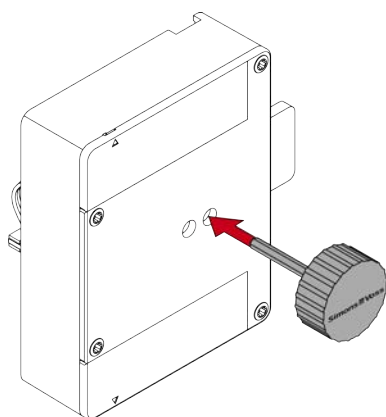

15. If necessary, plug in the flange extensions on the engine block.

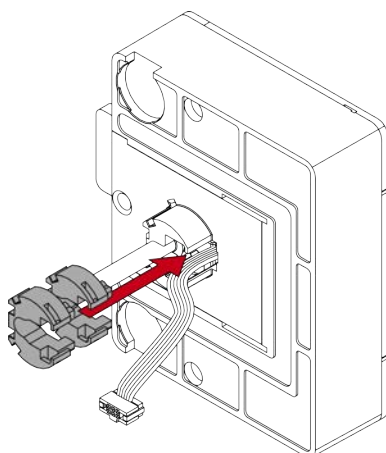

16. For wooden doors: Insert the fastening pieces into the recesses provided.

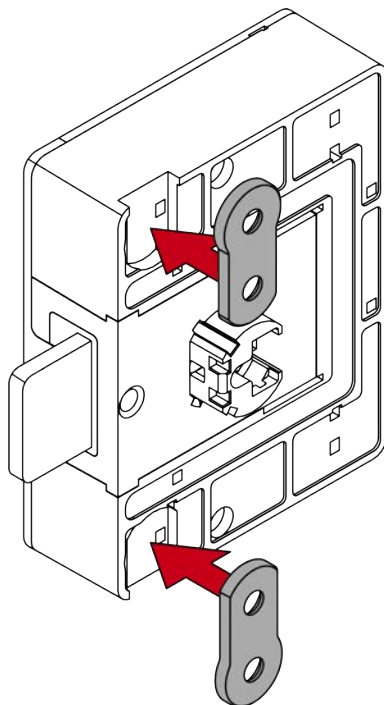

17. Hold the plastic mounting tool with one finger and place the engine block on the adapter plate or through the D-hole bushing.

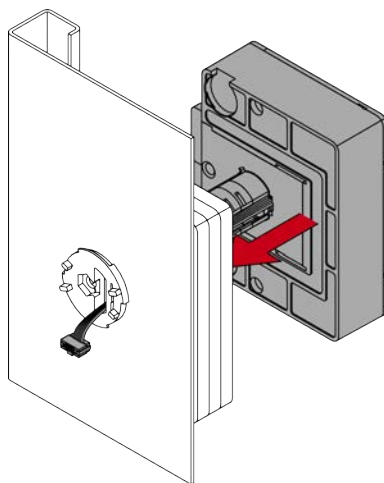

18. Thread the socket cable through the socket.

19. Place the nut on the screw and carefully tighten the nut with the assembly tool already inserted until it sits on the hexagonal mount.

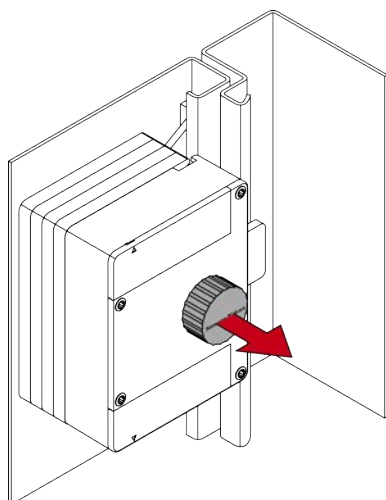
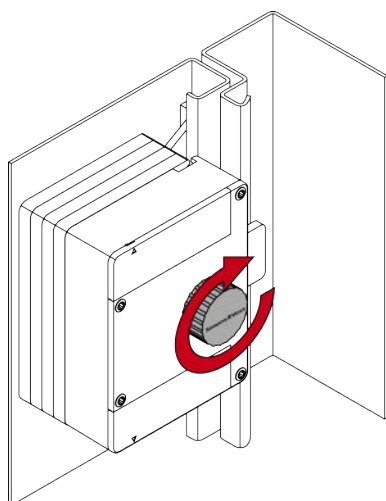
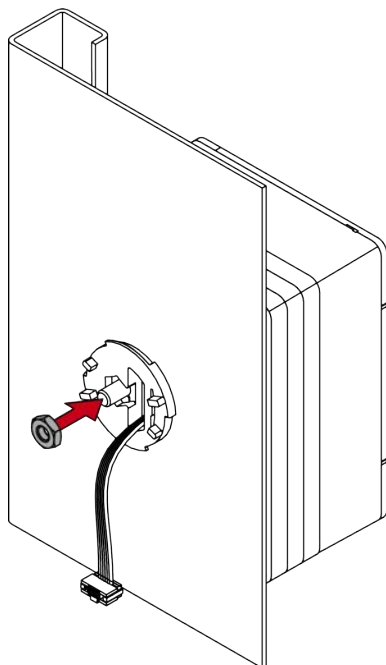

20. For wooden doors: Straighten the motor block and firmly tighten the fastening pieces with suitable screws.

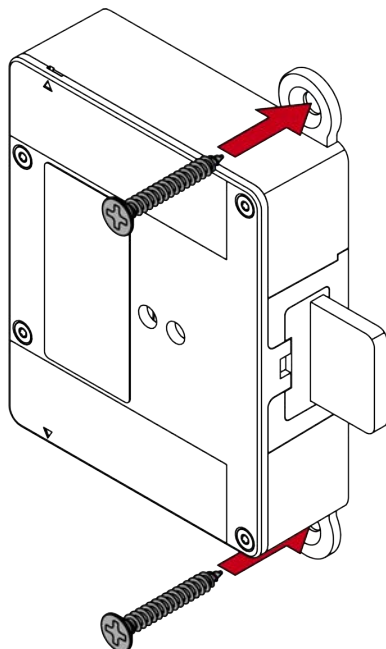

21. Tighten the nut with 1 Nm (2.5 mm hex wrench).

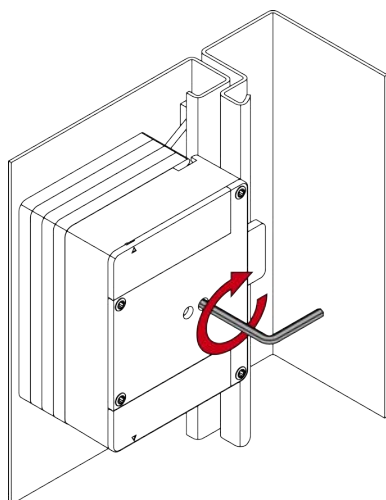
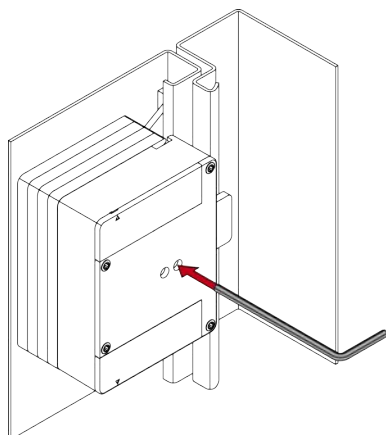

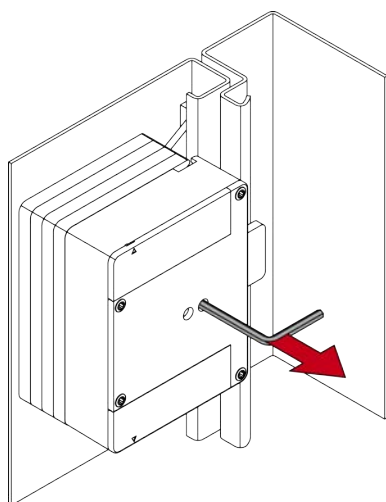

22. Insert the clamping element and the plastic countersunk screw into the D-hole bushing from the front.

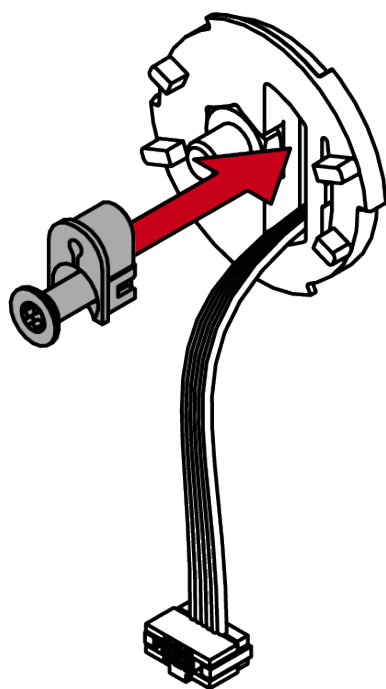

23. Screw the tensioner until it stops (TX10 key) without screwing through the screw.

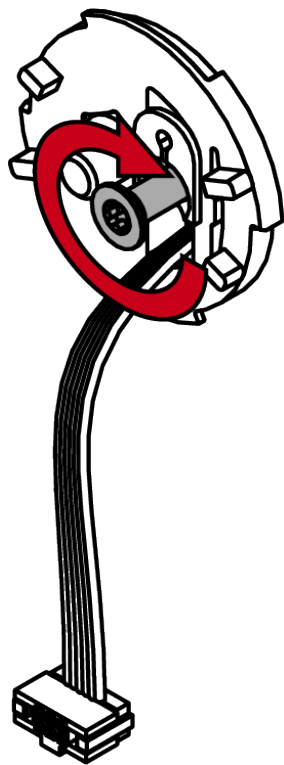

24. Place the reader at an angle (approx. 60°).

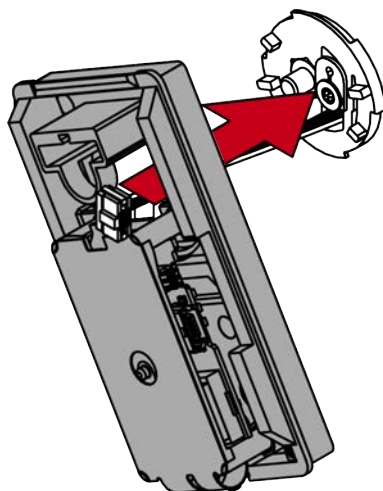

25. Turn the reader clockwise straight (bayonet mount).

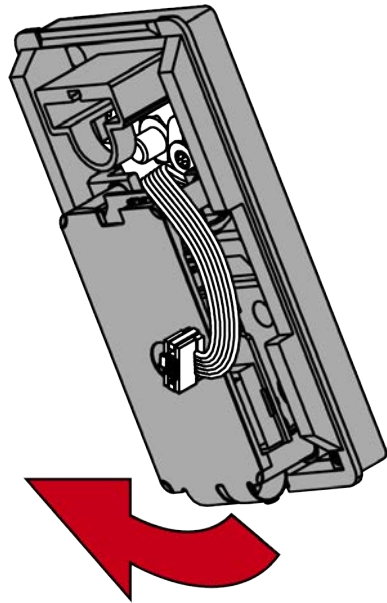

26. Route the cable past next to the area of the light guide.

27. Insert the plug into the socket with the lug facing the circuit board using the special tool.

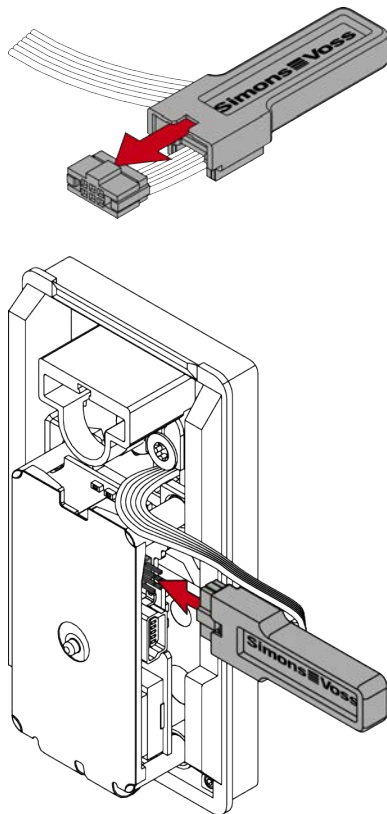

↳ The reader beeps and flashes three times.

28. Attach the light guide and press it firmly.

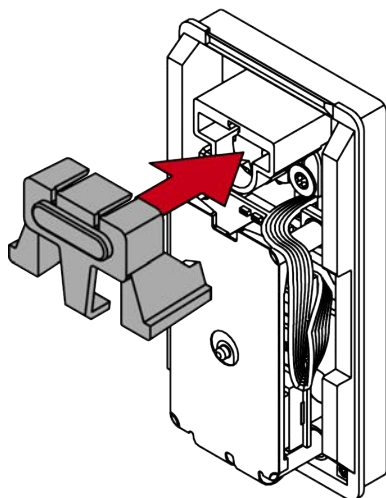

↳ Reader protected against twisting.

29. Store the excess cable in the gap next to the PCB.

30. Hook the lid on top.

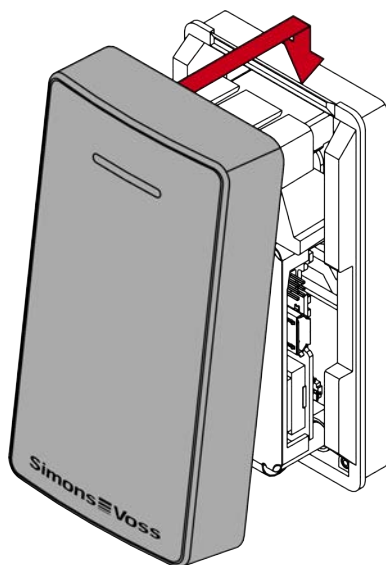

31. Close the lid downwards.

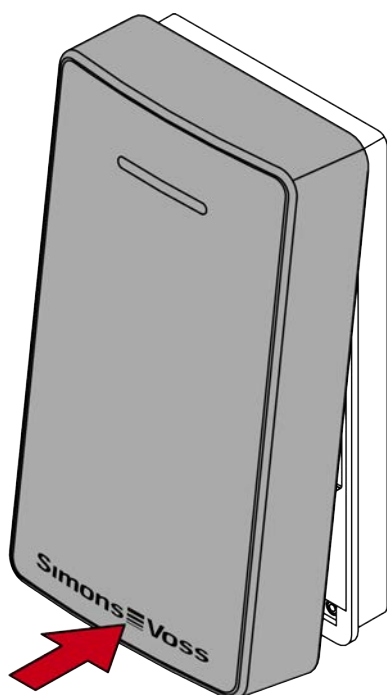

32. Gently press the lid against the floor and unscrew the lower screw counterclockwise (0.9 mm hex wrench) until it is flush with the lid surface.

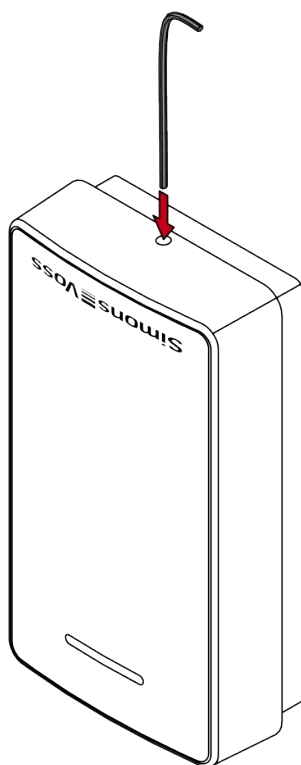

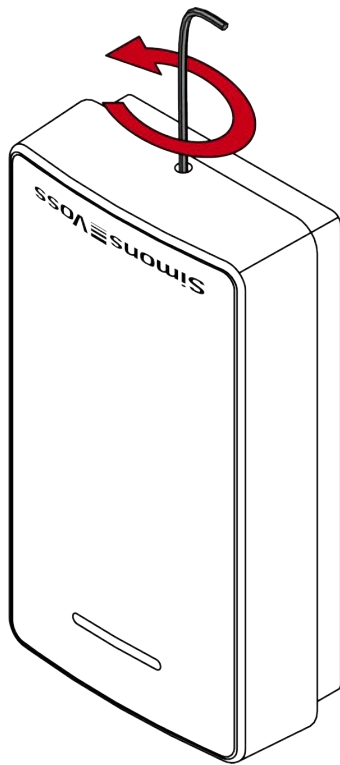

↳ SmartLocker AX is completely assembled.

6. Subsequent fixation on wooden doors

You can also attach the fixings to the SmartLocker AX after installation. To do this, insert the fixing elements into the already mounted SmartLocker AX and then screw them tight.

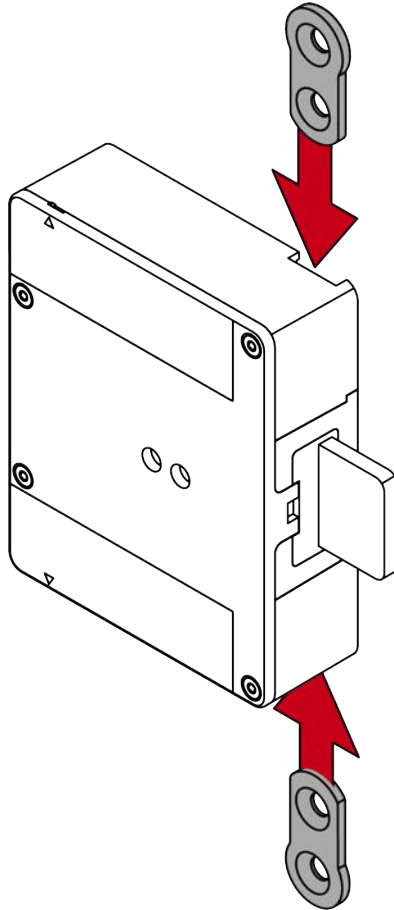

7. Operation

- Present an ID medium to the SmartLocker AX.
- ↳ SmartLocker AX signals reaction (see *Signalisation* [▶ 43]).
- ↳ SmartLocker AX reacts as configured.

8. LockNode

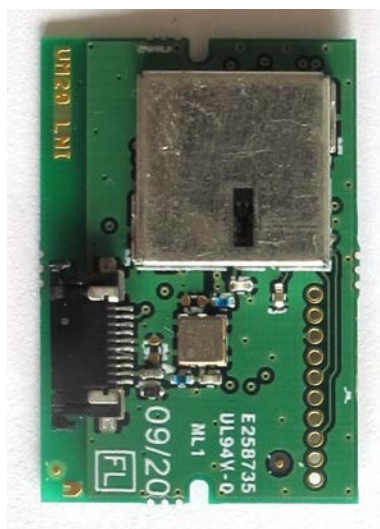

8.1 Intended use

With LockNode integrated (LNI) installed, you can network the SmartLocker AX and connect to WaveNet.

8.2 Installation

You will need the following tools:

- 0.9 mm hex wrench (included)
- Electronics needle-nosed pliers
- TX6 screwdriver

✓ Grounding completed (e.g. on radiator).

1. Insert the 0.9 mm hex key into the lower screw.

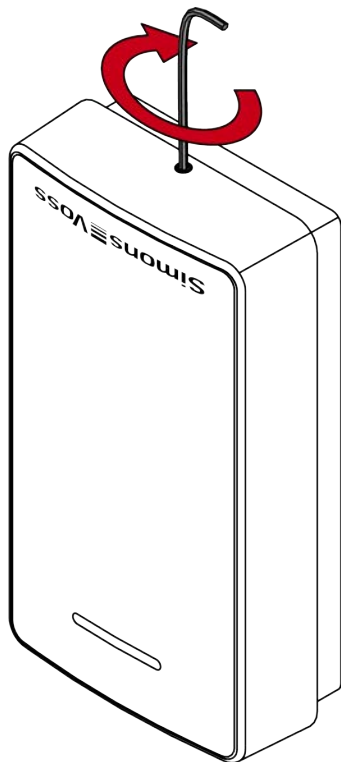

2. Gently press the reader cover against the floor and turn the lower screw clockwise inwards until you can lift off the cover.

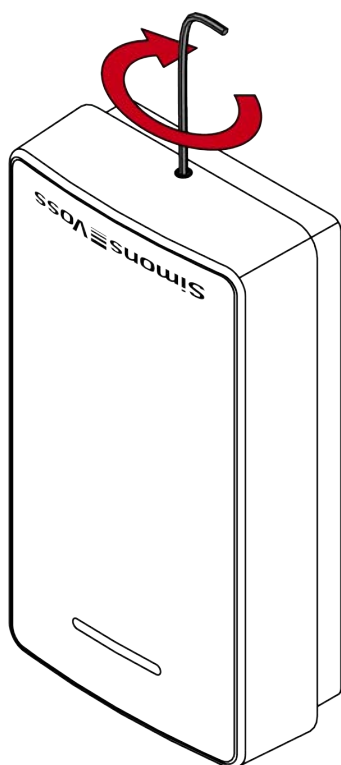

3. Remove the cover.

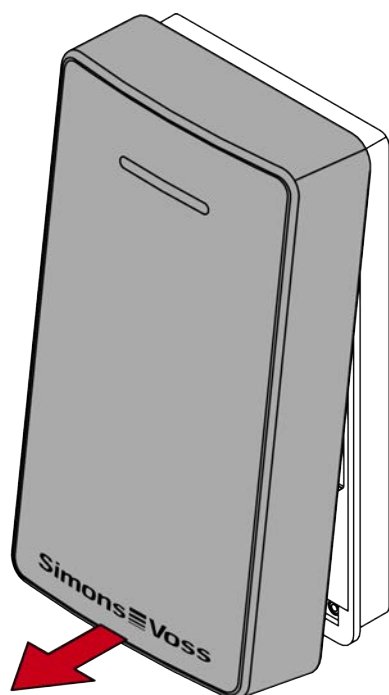

4. Pull the optical fibre out of the reader.

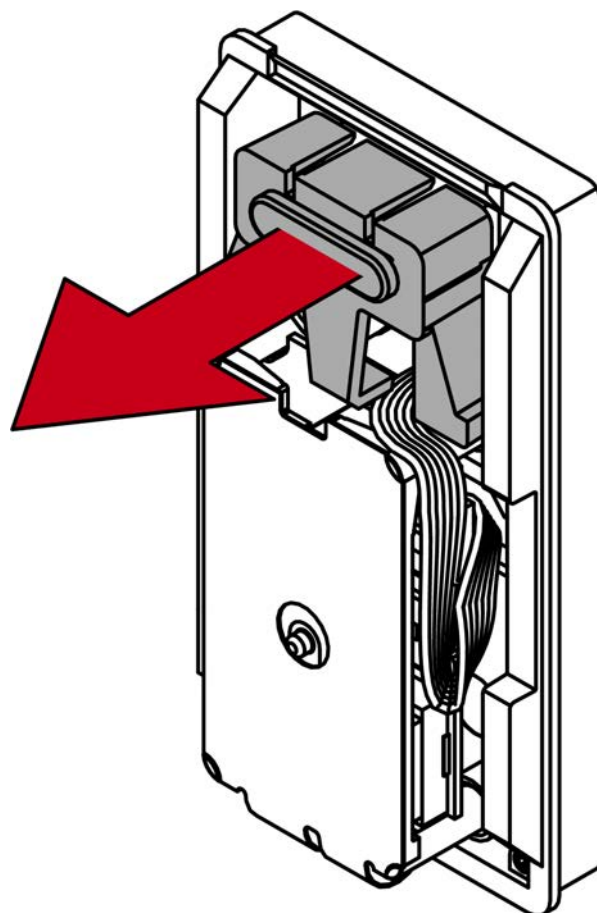

5. Using needle-nosed pliers, disconnect the plug of the cable below the circuit board.

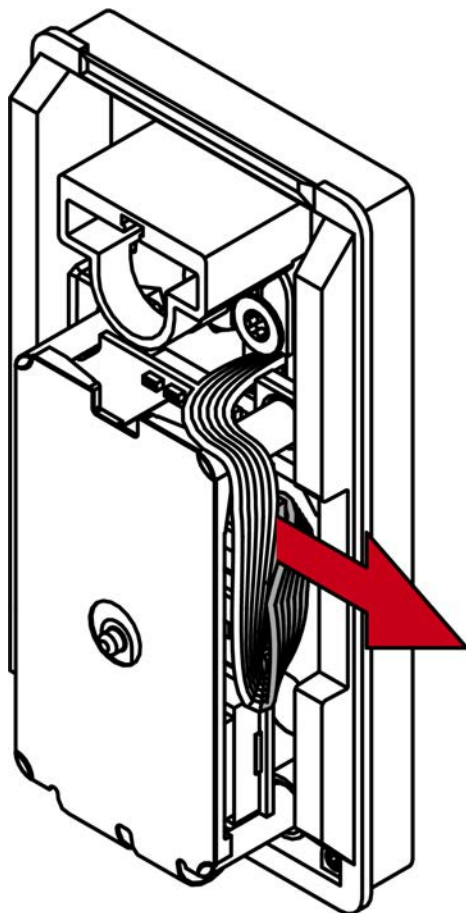

6. Turn the reader 60° anti-clockwise (bayonet mount).

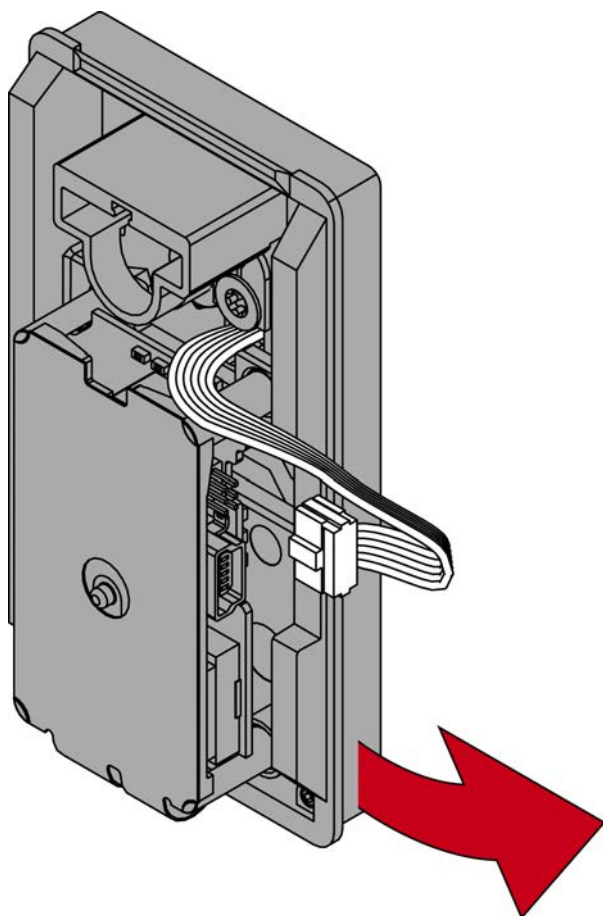

7. Remove the reader from the D socket.

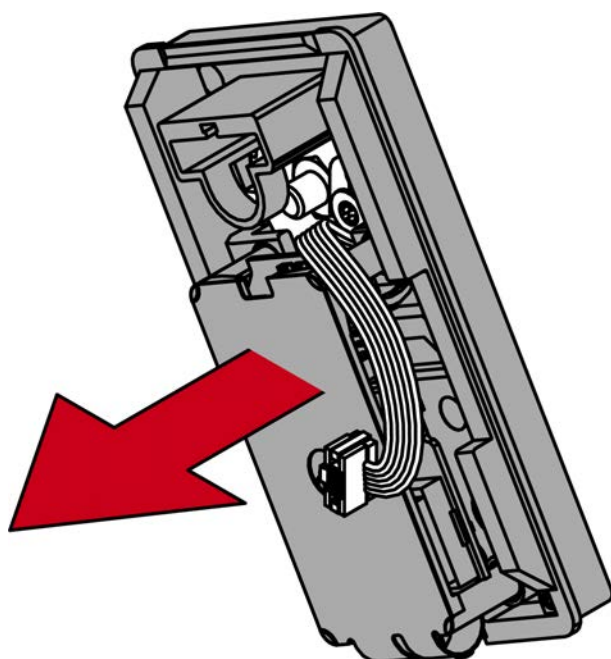

8. Undo the four screws from the circuit board mount to separate the circuit board mount from the reader base.

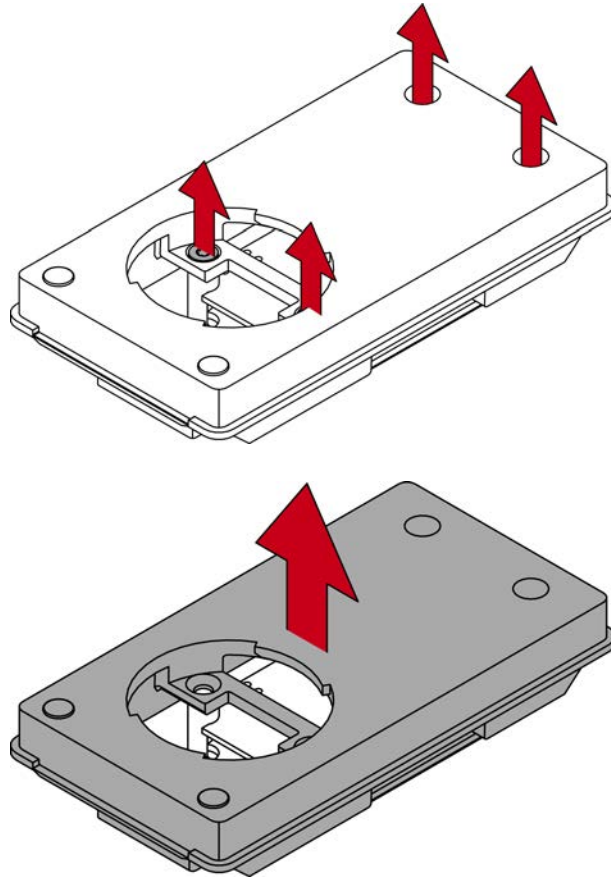

9. Open the FPC connector folding mechanism on the LNI.

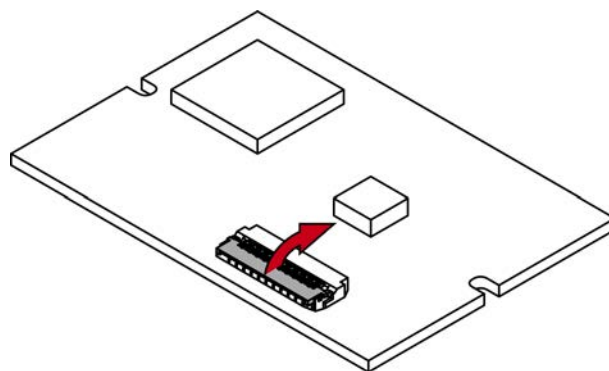

10. Insert the reader's non-assigned connection into the open FPC connector.

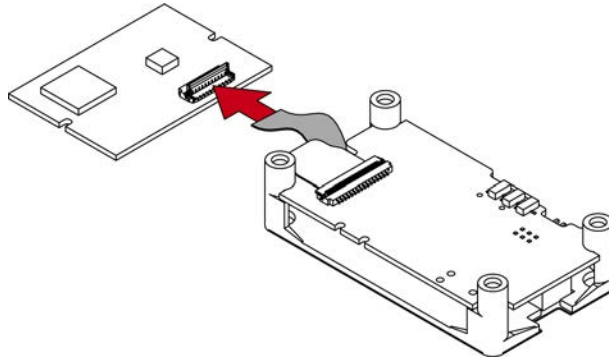

11. Close the FPC connector's folding mechanism.

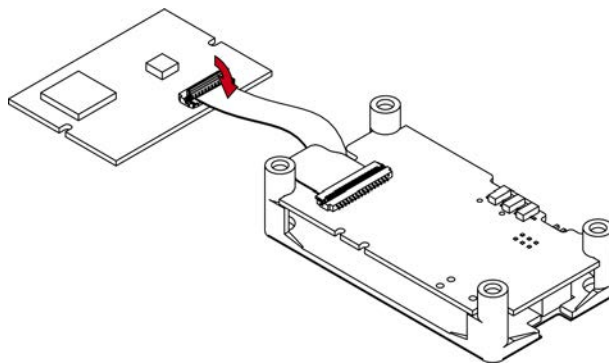

12. Screw the circuit board mount and the reader base back together.

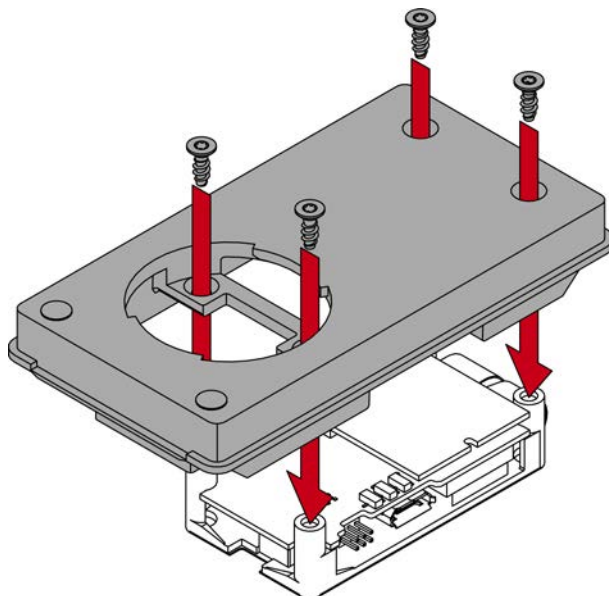

13. Place the reader at an angle (approx. 60°).

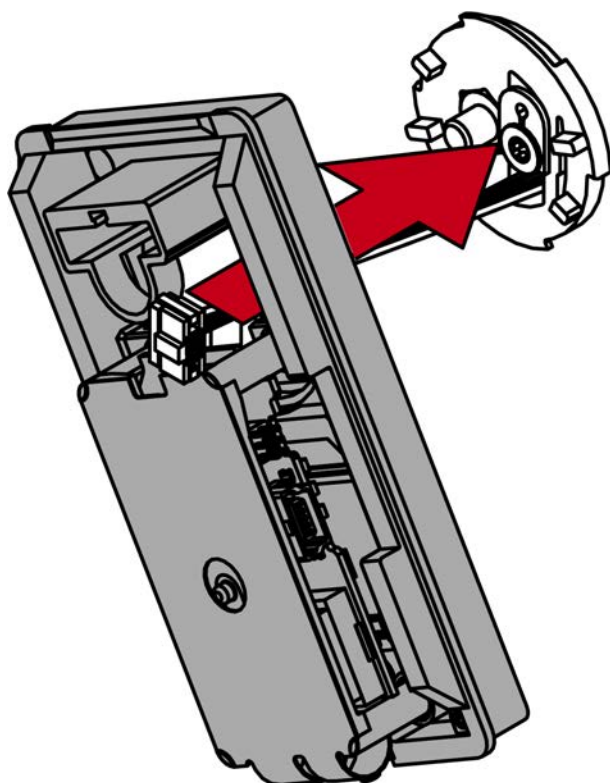

14. Turn the reader clockwise straight (bayonet mount).

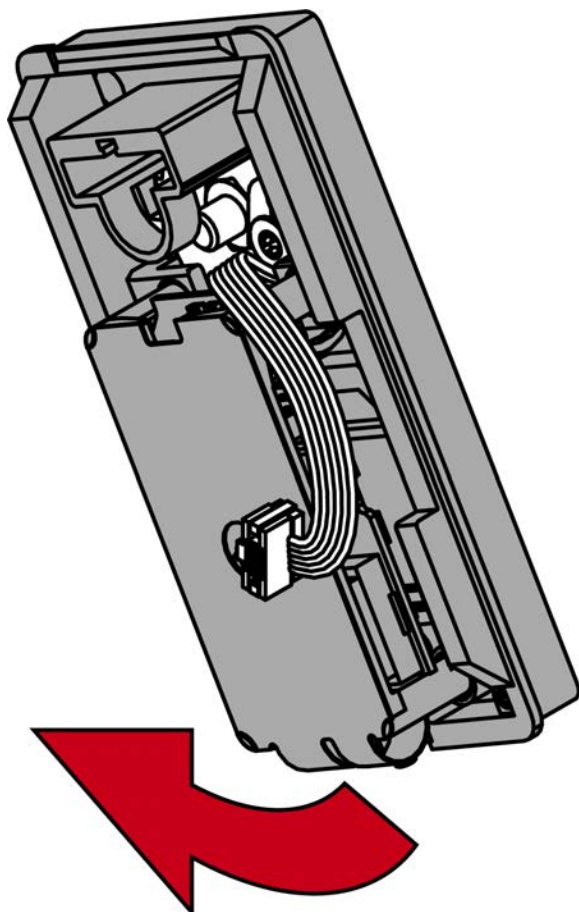

15. Route the cable past next to the area of the light guide.
16. Insert the plug into the socket with the lug facing the circuit board using the special tool.

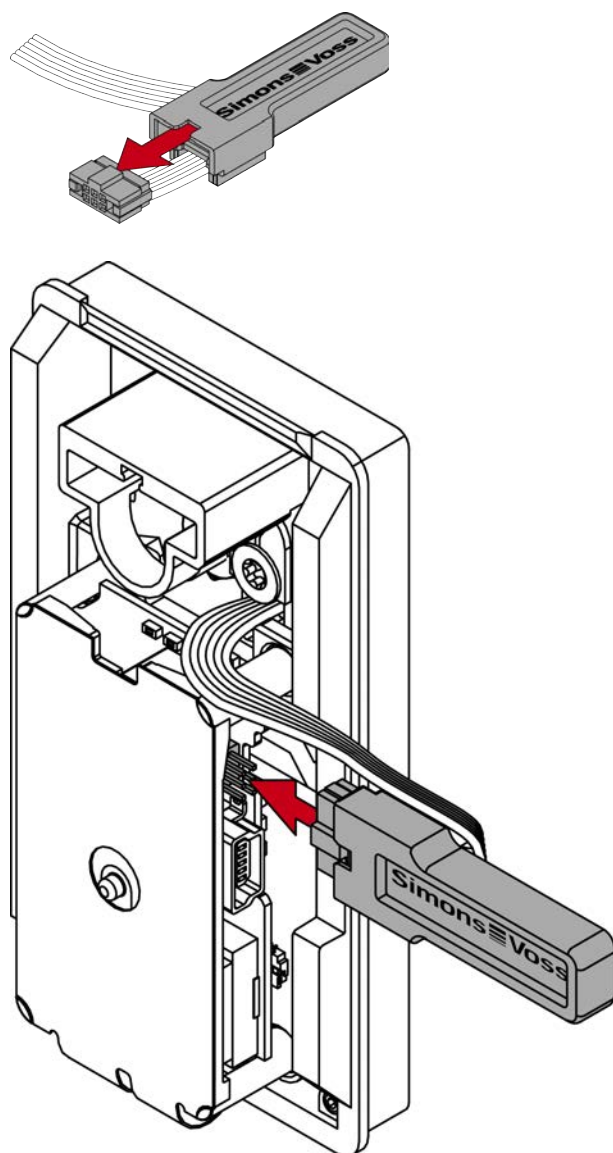

↳ The reader beeps and flashes three times.

17. Attach the light guide and press it firmly.

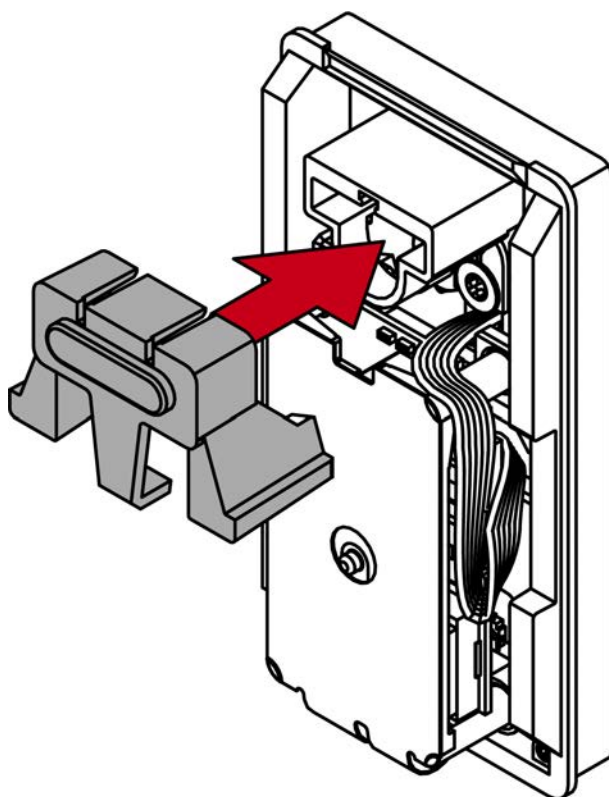

↳ Reader protected against twisting.

18. Store the excess cable in the gap next to the PCB.

19. Hook the lid on top.

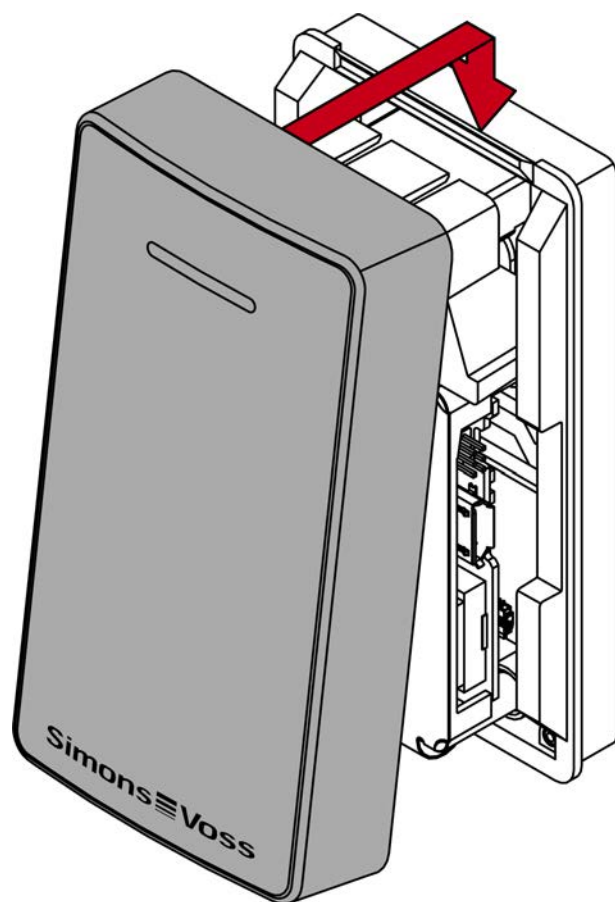

20. Close the lid downwards.

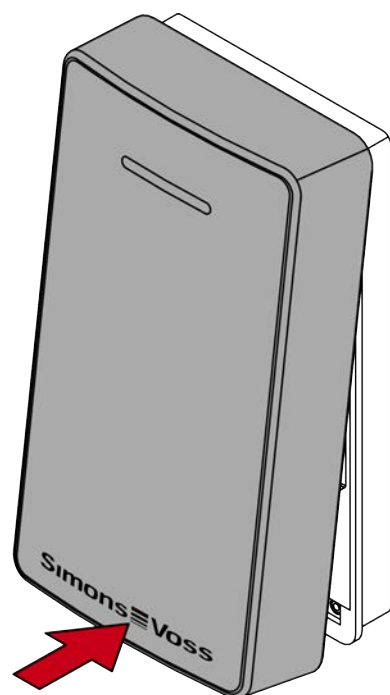

21. Gently press the lid against the floor and unscrew the lower screw anti-clockwise (0.9 mm hex wrench) until it is flush with the lid surface.

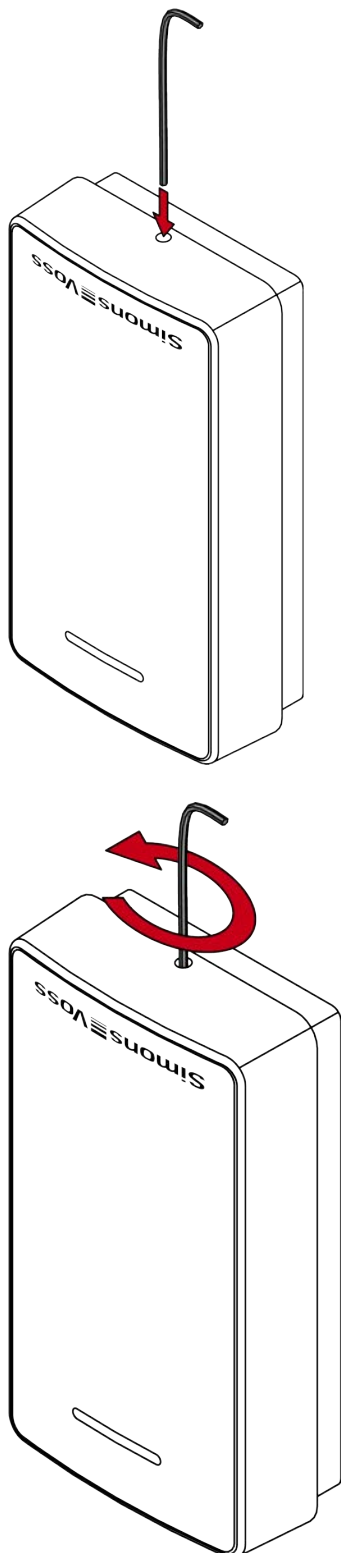

↳ LockNode installed in SmartLocker AX.

9. Battery change

- ✓ SmartLocker AX back accessible.
- ✓ Slot screwdriver available.

1. Put the slot screwdriver in the intended notch.

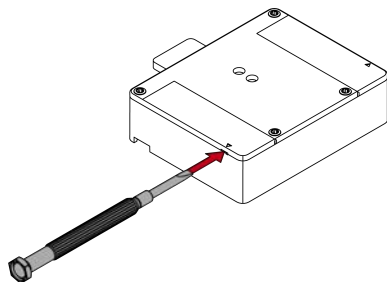

2. Turn the screwdriver as shown to lift the battery lid. Push the lid to the case's edge.

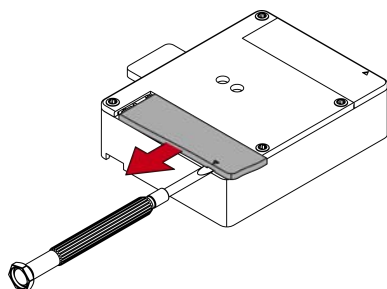
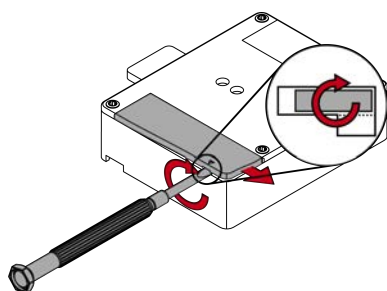

3. Change the battery. (see *Technical specifications* [[▶ 45](#)]).

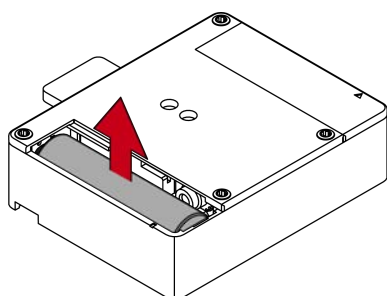

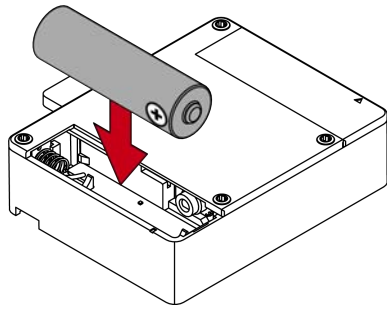

4. Hook in the lid's long flap first, then hook in the the short flap.

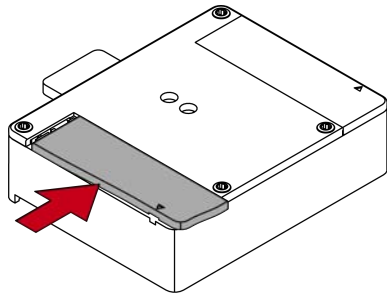

5. Push the lid against the case and push it in the direction of the short flap until it snaps in.

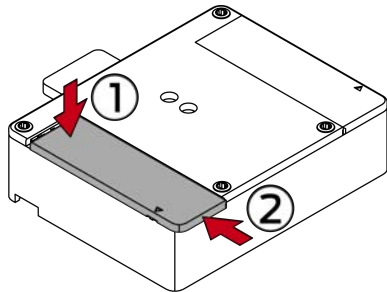

6. Use the same procedure for the other battery.

↳ SmartLocker AX beeps three times.

↳ Batteries are changed.

IMPORTANT

Varying behaviour due to rechargeable batteries

Rechargeable batteries discharge differently compared to batteries. Using rechargeable batteries results in varying battery life and faulty battery warnings.

■ Avoid using rechargeable batteries.

**NOTE****Emergency supply if totally discharged**

If you ignore the battery warnings, the SmartLocker AX may fail to open. If this happens the battery compartment is no longer accessible. You may connect an emergency power supply for changing the batteries.

9.1 Emergency power supply

1. Turn the screw at the reader's bottom clockwise to push it in (0.9 mm hexagon key).
2. Remove the cover.
3. Connect a power supply to the micro USB connector (e.g. USB plug, USB charger, powerbank).

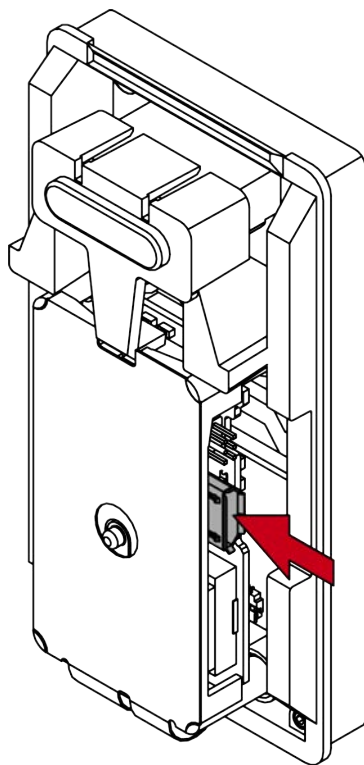

4. Present an ID medium.
↳ SmartLocker AX opens.
5. Open the locker, remove the micro USB cable and reassemble the reader.

10. Signalisation

Signal	Explanation
1× Beeping	Lock locked.
2× Beeping und Flashing (green)	Lock unlocked.
3 × Beeping	Reset/Battery change.
3× Beeping and Flashing	Motor unit and reader connected.
4 × Beeping and Flashing	LockNode connected.
8× Beeping and Flashing (red) before opening	Battery warning level 1. Batteries empty soon. Change. Remaining openings: Approx. 100
16× Beeping and Flashing (red) before opening	Battery warning level 2. Batteries empty. Change immediately. Remaining openings: Approx. 10

11. Disassembly

Disassembly is reversed to assembly. Carefully press the light guide down to make it easier to remove the cover.

12. Technical specifications

Dimensions (WxHxD)	Reader: 41.3×75.3×20.0 mm, motor block: 59×75×21 mm, bolt: 15×20×3 mm
Fastening	Standard locker lock flange (Ø19×16 mm) with double D punch
Material	Glass-fibre reinforced plastic
Colours	Anthracite
Weather protection	IP40
Temperature range (operation)	0 °C to +65 °C
Battery type	2x AA cell 1.5 V (alkaline)
Battery lifetime (3060)	Up to 60,000 lock operations or up to 5 years on standby (depending on read technology and operating mode)
Signalisation	- Audible signal (buzzer) and/or visual signal (LED – green/red)
Network capability	Yes (integrated LockNode can be ordered and retrofitted)
Reading technologies (3060)	Active (25 kHz), passive (MIFARE® Classic and DESFire EV1, EV2, EV3, hybrid (active and passive), Bluetooth Low Energy (BLE) in preparation
Networking modes	Online, virtual network and offline (can be combined)
Storable accesses (3060)	3,000
Time zone groups	100+1 (G2)
Number of identification media that can be managed per lock	Up to 64,000

Radio emissions

25 kHz (fL>10 kHz, fH<40 kHz)	-28.5 dBµA/m (10m distance)
13.560060 MHz - 13.560719 MHz	-14 dBµA/m (10 m distance)

868.000 MHz - 868.600 MHz / 869.700 MHz - 870.000 MHz Only for item numbers: SV- LL.*AM*LN*	<25 mW ERP (depending on equip- ment)
2360 MHz - 2500 MHz	4 mW

12.1 Dimensional drawings

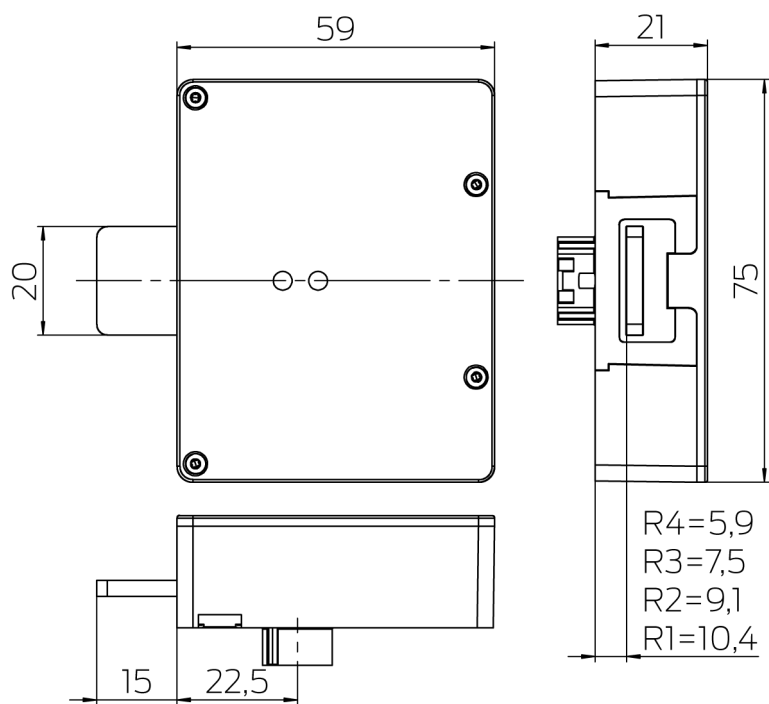

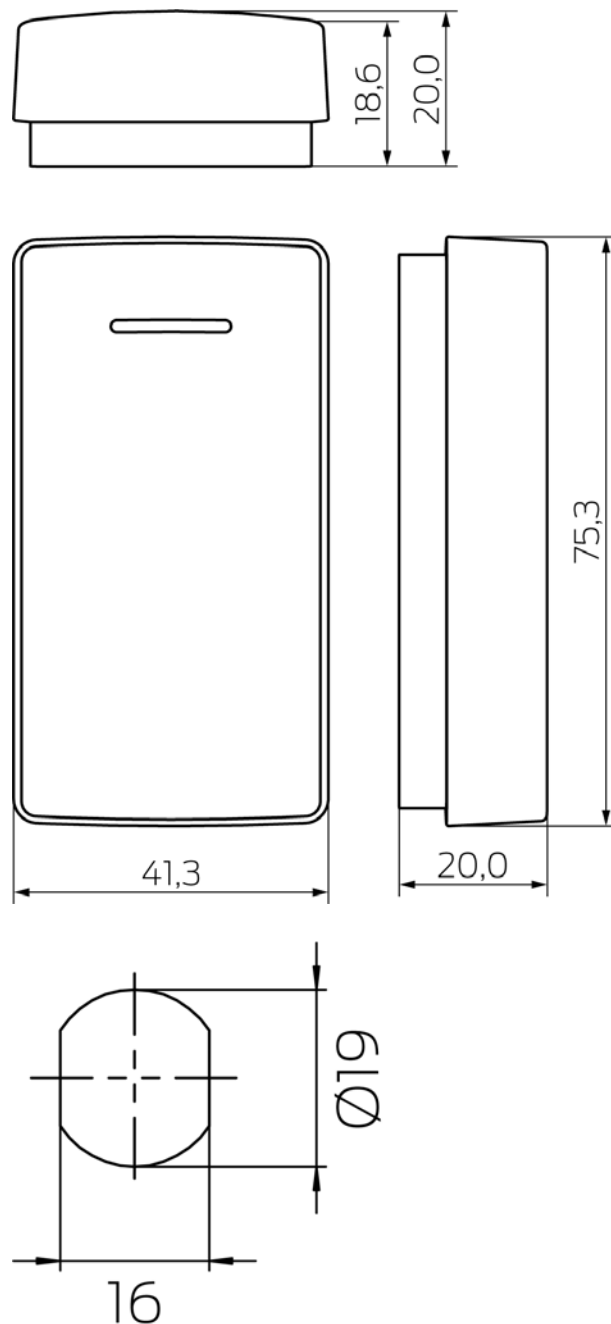

To assess compatibility, please note the following information:

Wooden doors

- The door must be between 10 mm and 25 mm thick.
With metal spindles, at least two adapter plates must therefore be used for standard material thicknesses (1 mm to 2 mm).
- Depending on the bolt block, the bolt has a clearance of 5.9 mm to 10.4 mm from the claw of the engine block. If necessary, you must attach adapter plates to the door frame so that the bolt rests on the door frame without play and the door does not fold.

Metal doors

- The door panel and adapter plates must be between 10 mm and 25 mm thick altogether.

With metal spindles, at least two adapter plates must therefore be used for standard material thicknesses (1 mm to 2 mm). However, due to the rebate in the door or frame, the use of adapter plates is usually required anyway.

- The deadbolt stop of the frame may not be more than 30.4 mm from the inside of the door when closed.
- The distance between the outside of the door and the inside of the bolt must not exceed 35.4 mm. This means that the maximum height of the rebate for metal doors is 10.4 mm (A).

12.2 Drawings of installation situations

Lockers and cupboards are available in many different designs. Compare your locker or cupboard with the drawings below to assess your personal installation situation.

Metal locker 1

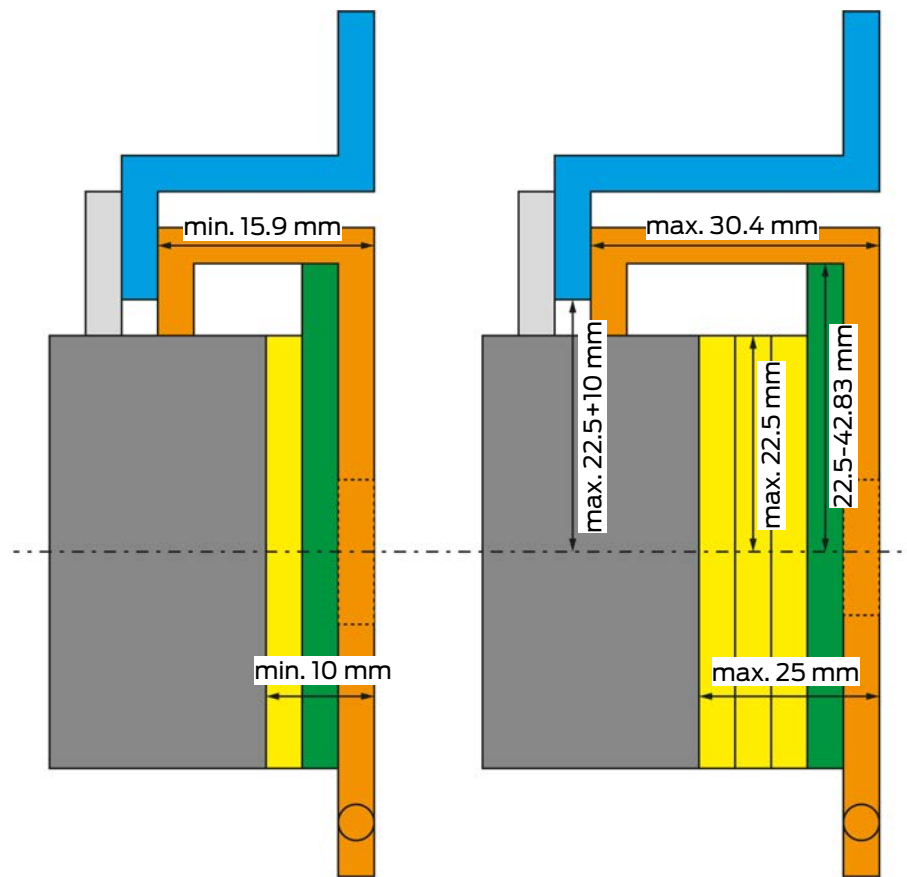

- Locker frame
- Bolt
- Motor block
- Door with hole and hinge
- Adapter plate 5 mm (variable)
- Adapter plate 5mm

Metal locker 2

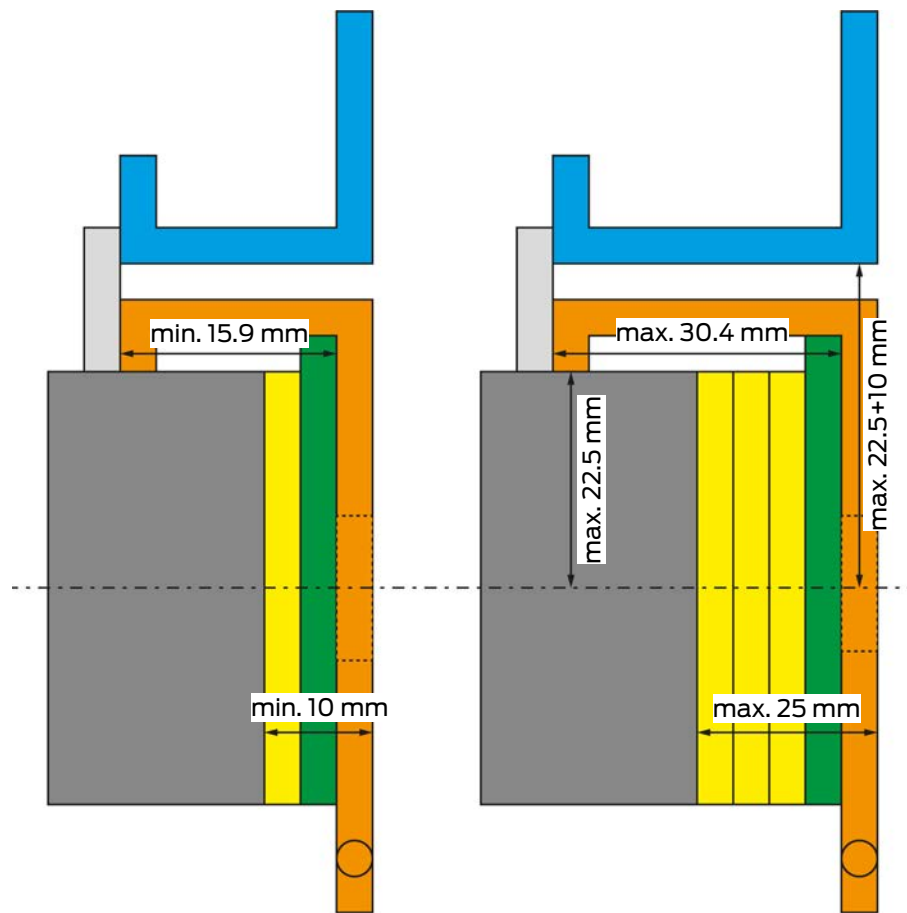

- Locker frame
- Bolt
- Motor block
- Door with hole and hinge
- Adapter plate 5 mm (variable)
- Adapter plate 5mm

Wooden locker

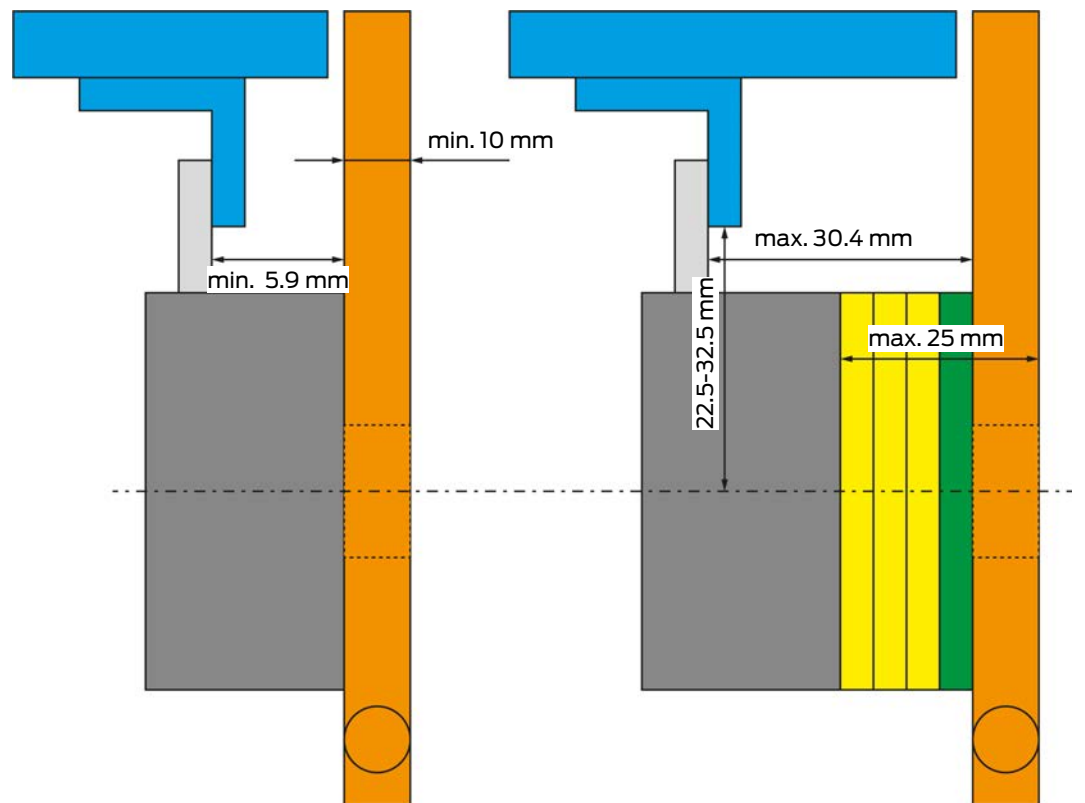

- Door frame with stop bracket
- Bolt
- Motor block
- Door with hole and hinge
- Adapter plate 5 mm (variable)
- Adapter plate 5 mm

13. Declaration of conformity

The company SimonsVoss Technologies GmbH hereby declares that the articles (SV-LL.*AM*LN*, SV-LL.*AM*) comply with the following guidelines:

- 2014/53/EU -RED-
or for the UK: UK statutory 2017 No. 1206 -Radio equipment-
- 2011/65/EU -RoHS-
or for the UK: UK statutory 2012 No. 3032 -RoHS-



The full text of the EU Declaration of conformity is available at the following internet address: www.simons-voss.com/en/certificates.html.

The full text of the UK Declaration of conformity is available at the following internet address: www.simons-voss.com/en/certificates.html.

14. Help and other information

Information material/documents

You will find detailed information on operation and configuration and other documents on the website:

<https://www.simons-voss.com/en/documents.html>

Declarations of conformity

You will find declarations of conformity and other certificates on the website:

<https://www.simons-voss.com/en/certificates.html>

Information on disposal

- Do not dispose the device (SV-LL.*AM*LN*, SV-LL.*AM*) in the household waste. Dispose of it at a collection point for electronic waste as per European Directive 2012/19/EU.
- Recycle defective or used batteries in line with European Directive 2006/66/EC.
- Observe local regulations on separate disposal of batteries.
- Take the packaging to an environmentally responsible recycling point.



Technical support

Our technical support will be happy to help you (landline, costs depend on provider):

+49 (0) 89 / 99 228 333

Email

You may prefer to send us an email.

support-simonsvoss@allegion.com

FAQs

You will find information and help in the FAQ section:

<https://faq.simons-voss.com/otrs/public.pl>

Address

SimonsVoss Technologies GmbH
Feringastr. 4
D-85774 Unterfoehring
Germany



This is SimonsVoss

SimonsVoss, the pioneer in remote-controlled, cable-free locking technology provides system solutions with a wide range of products for SOHOs, SMEs, major companies and public institutions. SimonsVoss locking systems combine intelligent functionality, high quality and award-winning design Made in Germany.

As an innovative system provider, SimonsVoss focuses on scalable systems, high security, reliable components, powerful software and simple operation. As such, SimonsVoss is regarded as a technology leader in digital locking systems.

Our commercial success lies in the courage to innovate, sustainable thinking and action, and heartfelt appreciation of employees and partners.

SimonsVoss is a company in the ALLEGION Group, a globally active network in the security sector. Allegion is represented in around 130 countries worldwide (www.allegion.com).

Made in Germany

SimonsVoss is truly committed to Germany as a manufacturing location: all products are developed and produced exclusively in Germany.

© 2024, SimonsVoss Technologies GmbH, Unterföhring

All rights are reserved. Text, images and diagrams are protected under copyright law.

The content of this document must not be copied, distributed or modified. More information about this product can be found on the SimonsVoss website. Subject to technical changes.

SimonsVoss and MobileKey are registered brands belonging to SimonsVoss Technologies GmbH.

SimonsVoss
technologies

Made in Germany

A BRAND OF

ALLEGION™