

Digital Half Cylinder 3061

State of: June 2006

Digital Half Cylinder 3061

Content



1.0	Method of Operation	4
1.1	General Information	4
1.2	Opening and Locking	4
2.0	Special Models	4
2.1	PLUS Version	4
3.0	Additional Functions	5
3.1	OMRON	5
3.2	Extending the Coupling Time	5
3.3	Logging Unauthorized Access Attempts	5
3.4	No Acoustic Programmer Acknowledge	5
4.0	Battery Warnings	5
4.1	Half Cylinder	5
4.2	Transponder	6
5.0	Battery Replacement	6

Digital Half Cylinder 3061

Content

6.0	Installation Instructions	7
6.1	General Information	7
6.2	Programming a Half Cylinder	7
6.3	Installing in Doors	7
6.4	Installation Behind Blanks for Half Cylinders With 3 <u>Setscrews</u>	8
	(New Flange Mounting)	8
6.4.1	Removal of the Knob and Flange of the Half Cylinder	8
6.4.2	Installing the Knob and Flange of the Half Cylinder	9
6.5	Installation Behind Blanks for Half Cylinders With 2 <u>Setscrews</u>	9
	(Old Flange Mounting)	9
6.5.1	Removal of the Knob and Flange of the Half Cylinder	10
6.5.2	Installing the Knob and Flange of the Half Cylinder	10
6.6	Perform Function Test	11
7.0	Data Sheet	12

1.0 Method of Operation

1.0 General Information

The outer dimensions of the Digital Half Cylinder exactly match those of a mechanical cylinder complying with DIN 18252. Please ask for approved self-locking and anti-panic locks at the manufacturer.

1.1 Opening and Locking

When not activated, the outer knob turns freely. It is not possible to open the door or to lock it. Hold the transponder at a distance of approximately 10 to 40 cm (4 to 16 inches) from the digital half cylinder and briefly press the transponder button once. If this is an authorised transponder, a double signal tone sounds and the cylinder couples. Now turn the outer knob in the locking or opening direction. You have approximately five seconds for this process. Then a single signal tone sounds and the outer knob turns freely again. Make sure that the outer knob of the half cylinder turns freely again after the coupling process.

👉 If this is a transponder that is not authorised at this time because of the time zone plan, a single signal tone sounds. The cylinder does not couple, however, and you cannot open the door.

2.0 Special Models

The Digital Half Cylinder 3061 is also available in the following optional versions:

2.0 PLUS Version

Design is similar to the standard version but with access logging and time zone control.

Access logging The locking cylinder stores the last 128 accesses with date, time and the user name of the transponder. You can read out the data with the PalmCD2 or over the network.

Time zone control You can program locking cylinders in such a way that authorised transponders are authorised for access only at certain times.

3.0 Additional Functions

3.1 OMRON

All product versions can be operated in OMRON mode. You will find a detailed description in the Smart Relay manual.

3.2 Extending the Coupling Time

The default time for the coupling of the cylinder is approximately 5 seconds. You can use the software to extend this time to approximately 10 seconds. This shortens the lifetime of the battery, however.

3.3 Logging Unauthorised Access Attempts

For cylinder version 10.2 and later and in combination with the LDB Version 1.40, it is possible to log unauthorised access attempts, as well as authorised accesses. This includes both access attempts without authorisation and access attempts outside the specified time zone. In this connection, however, only transponders from the locking system are logged, which means that the transponder must have the same locking system ID (SID).

3.4 No Acoustic Programmer Acknowledge

When programming over the network, it can be advantageous to deactivate the acoustic programmer acknowledge. You can do that with this function.

4.0 Battery Warnings

4.1 Half Cylinder

Warning level 1 for main battery

If the main battery of the half cylinder goes empty, eight short signal tones, coming quickly one after another, sound after you operate the transponder and before the cylinder couples. You must replace both batteries now.

Warning level 2 for backup battery (SW Version 10.0 & SW Version 10.1)

In addition to the main battery warning, an additional sixteen short signal tones, coming quickly one after another, sound for the backup battery warning. The cylinder does not couple until after the signals. From now on, the backup battery is active. You must replace both batteries as soon as possible.

Warning level 2 for backup battery (SW Version 10.2 and later)

In addition to the main battery warning, the signal tones of the backup battery warning now sound for approximately 30 seconds. The cylinder does not couple until after the signals. From now on, the backup battery is active. You must replace both batteries as soon as possible.

Warning Level 3 (SW version 10.3 and later)

If you continue to ignore the backup battery warning, either the door can be used 50 more times or the cylinder switches off after 4 - 5 weeks if there is no further operation. In both cases, the cylinder switches into the so-called storage mode. After this, you can only open the cylinder with the programming device.

4.2 Transponder

If the transponder battery voltage is coming to an end, eight short signal tones, coming quickly one after another, sound each time the transponder is operated and after the uncoupling.

👉 Attention: Do not take out the transponder battery because this will probably result in the loss of data. See the "Transponder 3064" manual for more information.

5.0 Battery Replacement

Only authorised personnel are permitted to replace the battery. Use only batteries that are supplied by SimonsVoss.

1. Firmly hold the knob and remove the locknut on the back of the knob from the knob with the special tool for half cylinders.
2. Use an authorised transponder to couple the cylinder and unscrew the knob by turning it counter-clockwise. While doing this, you must firmly hold the catch with your hand if the half cylinder is not installed. If the half cylinder is installed, the catch is held by the stop within the lock.
3. Replace the main and emergency batteries. Make sure that the polarity is correct.
4. Use an authorised transponder to couple the half cylinder and tightly screw the knob in until the stop. Make sure that the knob is screwed on up to the stop (important for the function). While doing this, you must firmly hold the catch with your hand if the half cylinder is not installed. If the half cylinder is installed, the catch is held by the stop within the lock.
5. Firmly hold the knob and use the special tool for half cylinders to firmly screw the locknut onto the knob.
6. Now operate an authorised transponder and test the function.

Dispose of used batteries immediately, keep out of reach of children, do not open and do not throw into a fire!

👉 Reversing the polarity can result in damage to the locking cylinder. Incorrect handling of the batteries used in this device can result in the risk of fire or burns. Do not charge, open, heat to more than 100° C (212° F) or burn.

👉 Never operate the cylinder without a main battery because otherwise the entire power consumption of the cylinder runs over the backup battery.

- 👉 For PLUS versions, you must reset the time of day after the battery change because the clock does not work without current (Software Operating Instructions: Programming → Setting the clock on the locking).

6.0 Installation Instructions

6.1 General Information

Only trained and authorised personnel are permitted to perform the installation. The battery used in the cylinder can present a risk of fire and burns if not handled correctly! Do not charge, open, heat to more than 100° C (212° F) or burn! Do not short-circuit! When installing the digital half cylinder, make sure that there are no sources of interference in the vicinity. You should install half cylinders at least 0.5 m (approximately 1.5 feet) from one another and Smart Relays or activation units at a distance of at least 1.5 m (approximately 5 feet). The PC housing of the half cylinder is not allowed to stick out into the exterior area more than 3 mm. If necessary, attach a profile cylinder rosette. Furthermore, you must ensure that no water can penetrate into the cylinder in the area of the catch.

6.2 Programming a Half Cylinder

You must program the digital locking cylinder and accompanying transponders in the locking plan before you install them. Please refer to the Software Operating Instructions for more detailed information.

- 👉 The locking cylinders are delivered in so-called storage mode, which means that no communication is possible with the transponder (exception: programming transponder). You can also use software and the programming device to remove the storage mode. Please refer to the Software Operating Instructions for more detailed information.

6.3 Installing in Doors

Insert the cylinder through the lock from the outside of the door towards the inside and secure it with the lock screw.

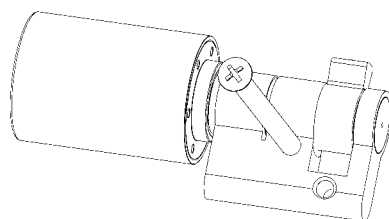

- 👉 Never hit against the knobs during installation. Do not bring the cylinder into contact with oil, paint or acid.

6.4 Installation Behind Blanks for Half Cylinders With 3 Setscrews (New Flange Mounting)

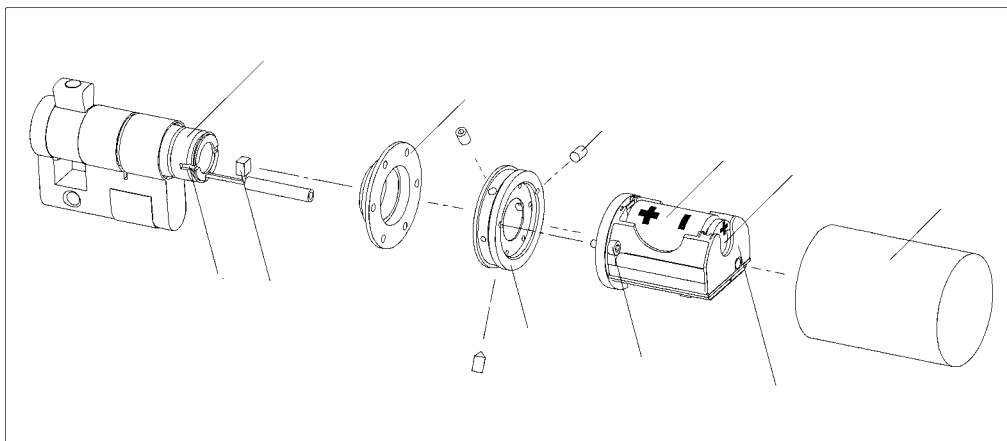

6.4.1 Removal of the Knob and Flange of the Half Cylinder

1. Firmly hold the knob and remove the locknut on the back of the knob from the knob with the special tool for half cylinders. (If the locknut is already bumping into the profile, then start to unscrew the knob as described in the following point (approximately one rotation) and continue).
2. Use an authorised transponder to couple the cylinder and then unscrew the knob. While doing this, you must firmly hold the catch with your hand if the half cylinder is not installed. If the half cylinder is installed, the catch is held by the stop within the lock.
3. Carefully pull the cable out of the socket-contact in the electronics but do not remove the insulation sleeving. The electronic covering is thermally welded on and also remains on the unit.
4. Remove the two Allen screws that are parallel to the battery from the flange with an Allen key (1.5 mm). Remove the electronics module.
5. Remove the three setscrews on the outer circumference of the flange (same Allen key).
Note: If you can see two setscrews here, this cylinder has an old flange mounting (in this case, refer to Point 6.5).
6. Remove the flange and locknut.
7. Now you can install the blank.

6.4.2 Installing the Knob and Flange of the Half Cylinder

1. Put on the locknut. The flat surface with the bore holes faces away from the cylinder.
Note: If you cannot see any screw thread on the end of the pipe, this cylinder has a new flange mounting (in this case, refer to Point 6.4).
2. Put the flange onto the end of the pipe; the side of the flange with the screw thread faces away from the cylinder. The flange contains a crosspin that sticks out of the interior diameter. This crosspin must catch in the longitudinal slot of the pipe. Push the flange up against the stop on the pipe.
3. Holding it in this position, fix the three setscrews very tightly with the Allen key (1.5 mm). Check whether the setscrews are really tightly screwed, because this is important for correct functioning.
4. Fix the electronics module to the flange with the Allen screws that are parallel to the battery (same Allen key as above). Guide the cable through the recess next to the connector. Make sure that the cable is not pinched.
5. Connect the cable to the electronics socket and lay it so that it is flat on the electronics covering and not in the way when screwing on the knob (danger of pinching).
6. Use an authorised transponder to couple the half cylinder and tightly screw the knob in until the stop. Make sure that the knob is screwed on up to the stop (important for the function). While doing this, you must firmly hold the catch with your hand if the half cylinder is not installed. If the half cylinder is installed, the catch is held by the stop within the lock.
7. Firmly hold the knob and use the special tool for half cylinders to firmly screw the locknut onto the knob.

6.5 Installation Behind Blanks for Half Cylinders With 2 Setscrews (Old Flange Mounting)

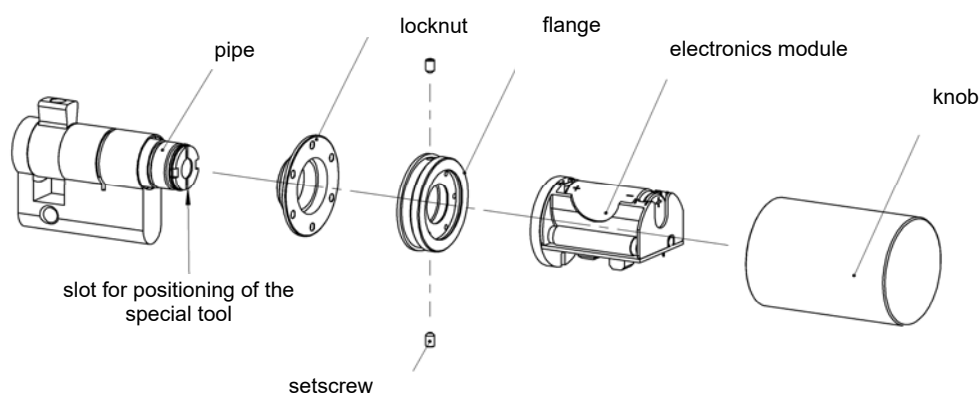

6.5.1 Removal of the Knob and Flange of the Half Cylinder

1. Firmly hold the knob and remove the locknut on the back of the knob from the knob with the special tool for half cylinders.
2. Use an authorised transponder to couple the cylinder and then unscrew the knob. While doing this, you must firmly hold the catch with your hand if the half cylinder is not installed. If the half cylinder is installed, the catch is held by the stop within the lock.
3. Carefully pull the cable out of the socket-contact in the electronics but do not remove the insulation sleeving. The electronic covering is thermally welded on and also remains on the unit.
4. Remove the two Allen screws that are parallel to the battery from the flange with an Allen key (1.5 mm). Remove the electronics module.
5. Remove the setscrew on the outer circumference of the flange (same Allen key). Note: If you can see 3 setscrews here, this cylinder has a new flange mounting (in this case, refer to Point 6.4)
6. The fore-part of the pipe, which sticks out of the profile, contains two slots on which you can position the special tool (offset 90° to the lengthwise slot which guides the cable). The narrow end of the installation tool can move into this slot. This ensures that the pipe cannot twist.
7. Now you can unscrew the flange without the pipe also turning.
8. Remove the locknut.
9. Now you can install the blank.

6.5.2 Installing the Knob and Flange of the Half Cylinder

1. Put on the locknut. The flat surface with the bore holes faces away from the door.
Note: If you cannot see any screw thread on the end of the pipe, this cylinder has a new flange mounting (refer to Point 6.4).
2. Please note the two lateral impressions on opposite sides of the pipe. The lateral setscrews of the flange must fit into this later in order to guarantee that the flange holds securely. To find the exact position quickly, the flat surfaces of the pipe and flange have black markings that must line up.
3. Put the flange on the end of the pipe without screwing it in. The side with the small outside diameter points towards the door. The fore-part of the pipe, which sticks out of the profile, contains two slots in which you can position the special tool (offset 90° to the lengthwise slot which guides the cable). The narrow end of the installation tool can move into this slot. This ensures that the pipe cannot twist.
4. The pipe should not turn during the following steps (see Point 3). Lightly screw on the flange until it reaches the stop and the markings line up. In this position, tighten the two setscrews with the Allen key (1.5 mm) so that they center in the indentations of the pipe. Then tighten both setscrews securely. Please check whether the setscrews are really tightly screwed, because this is important for correct functioning!

5. Fix the electronics module to the flange with the Allen screws that are parallel to the battery (same Allen key). Make sure that the cable is not pinched.
6. Connect the cable to the electronics socket and lay it so that it is flat on the electronics covering and not in the way when screwing on the knob (danger of pinching).
7. Use an authorised transponder to couple the half cylinder and tightly screw the knob in until the stop. While doing this, you must firmly hold the catch with your hand if the half cylinder is not installed. If the half cylinder is installed, the catch is held by the stop within the lock.
8. Firmly hold the knob and use the special tool for half cylinders to firmly screw the locknut onto the knob.

6.6 Perform Function Test

1. Operate an authorised transponder and turn the knob in the lock and open directions when the door is open. The knob must turn easily.
2. Close the door and repeat the process. If the locking cylinder is stiff, you must align the door or correct the edge plate.

7.0 Data Sheet

Dimensions	Standard length	30/10 mm
	Max. profile length	100 mm (in 5mm intervals)
	Knob diameter	32 mm
	Knob length	51.5 mm (distance from knob end to profile fore-part)
	Standard for profile dimensions	DIN 18252

Battery	Batteries	Lithium, 3.6V, ½ AA, 900mAh Lithium 3V, CR1220 Use only original replacement batteries from SimonsVoss
	Service life	Max. 50,000 operations or roughly 4 years

Environmental Conditions	Operating temperature range	-20°C to +50°C (-4°F to +122°F)
	Storage temperature range	-35°C to +50°C (-31°F to +122°F)
	Degree of protection	IP 54 (when installed)
