



SOM + SREL3.ADV

Manual

29.08.2020

Simons  Voss
technologies

Content

1	General safety instructions.....	4
2	Product-specific safety instructions.....	7
3	Meaning of the text formatting	8
4	Product description.....	9
5	Before placing an order	10
5.1	SmartRelay	10
5.2	Determining the number of required modules	10
5.3	Acquiring and configuring power supply units.....	10
5.4	Determining installation technology and location	10
5.5	Cable types and routes	10
5.6	installation outside.....	10
5.7	Guidelines	10
6	Before installation	11
7	Installation	12
8	Connections.....	13
9	Connection to the SmartRelay	16
9.1	Standard power supply unit connection.....	16
9.2	Connecting a fire alarm system emergency release	17
9.3	Circuit to prevent opening if power supply should fail	17
10	Programming and configuration.....	19
10.1	General information.....	19
10.2	Entering the number of modules	19
10.3	Configuring the address for modules.....	19
10.4	Setting the pulse length.....	20
10.5	Naming in the software.....	20
10.6	Inverting outputs	20
11	Signal	22
11.1	LEDs for each output	22
11.2	Status LED.....	22
12	Technical specifications	23
13	Declaration of conformity	26

14 Help and other information 27

1 General safety instructions

Signal word (ANSI Z535.6)	Possible immediate effects of non-compliance
DANGER	Death or serious injury (likely)
WARNING	Death or serious injury (possible, but unlikely)
CAUTION	Minor injury
IMPORTANT	Property damage or malfunction
NOTE	Low or none



WARNING

Blocked access

Access through a door may stay blocked due to incorrectly fitted and/or incorrectly programmed components. SimonsVoss Technologies GmbH is not liable for the consequences of blocked access such as access to injured or endangered persons, material damage or other damage!

Blocked access through manipulation of the product

If you change the product on your own, malfunctions can occur and access through a door can be blocked.

- Modify the product only when needed and only in the manner described in the documentation.



CAUTION

Fire hazard posed by batteries

The batteries used may pose a fire or burn hazard if handled incorrectly.

1. Do not try to charge, open, heat or burn the batteries.
2. Do not short-circuit the batteries.

IMPORTANT

Damage resulting from electrostatic discharge (ESD)

This product contains electronic components that may be damaged by electrostatic discharges.

1. Use ESD-compliant working materials (e.g. Grounding strap).
2. Ground yourself before carrying out any work that could bring you into contact with the electronics. For this purpose, touch earthed metallic surfaces (e.g. door frames, water pipes or heating valves).

Damage resulting from liquids

This product contains electronic components that may be damaged by liquids of any kind.

- ❑ Keep liquids away from the electronics.

Damage resulting from aggressive cleaning agents

The surface of this product may be damaged as a result of the use of unsuitable cleaning agents.

- ❑ Only use cleaning agents that are suitable for plastic or metal surfaces.

Damage as a result of mechanical impact

This product contains electronic components that may be damaged by mechanical impacts of any kind.

1. Avoid touching the electronics.
2. Avoid other mechanical influences on the electronics.

Damage as a result of overcurrent or overvoltage

This product contains electronic components that may be damaged by excessive current or voltage.

- ❑ Do not exceed the maximum permissible voltages and/or currents.

Damage due to polarity reversal

This product contains electronic components that may be damaged by reverse polarity of the power source.

- ❑ Do not reverse the polarity of the voltage source (batteries or mains adapters).

Failure of operation due to different discharged batteries

This product uses one or more batteries for power supply. The batteries are discharged at approximately the same rate.

- ❑ Always replace all batteries at the same time.



NOTE

Intended use

SimonsVoss-products are designed exclusively for opening and closing doors and similar objects.

- ❑ Do not use SimonsVoss products for any other purposes.

Battery contact malfunction due to grease film

When touching batteries, leave a thin film of skin grease on the batteries. This film deteriorates the contact between the electronics and the batteries.

1. Do not touch the contacts of the new batteries with your hands.
2. Use clean and grease-free gloves.

Dispose of the batteries as per local and country-specific regulations.

Function error due to poor battery contact

If the contact surface to the battery is too small, then the battery connection may not create a stable connection to the battery.

- Only use batteries that are approved by SimonsVoss.

Different times for G2 locks

The internal time unit of the G2 locks has a technical tolerance of up to ± 15 minutes per year.

Qualifications required

The installation and commissioning requires specialized knowledge.

- Only trained personnel may install and commission the product.

Modifications or further technical developments cannot be excluded and may be implemented without notice.

The German language version is the original instruction manual. Other languages (drafting in the contract language) are translations of the original instructions.

Read and follow all installation, installation, and commissioning instructions. Pass these instructions and any maintenance instructions to the user.

2 Product-specific safety instructions

IMPORTANT

SimonsVoss Technologies GmbH accepts no liability for any damage caused by incorrect installation.

IMPORTANT

You must observe the manufacturer's warranty and installation conditions if you use other manufacturers' products with a SmartOutput module.

3 Meaning of the text formatting

This documentation uses text formatting and design elements to facilitate understanding. The table explains the meaning of possible text formatting:

Example	button
<input checked="" type="checkbox"/> Example	checkbox
<input type="checkbox"/> Example	
<input checked="" type="radio"/> Example	Option
[Example]	Tab
"Example"	Name of a displayed window
Example	Upper programme bar
Example	Entry in the expanded upper programme bar
Example	Context menu entry
▼ Example	Name of a drop-down menu
"Example"	Selection option in a drop-down menu
"Example"	Area
Example	Field
<i>Example</i>	Name of a (Windows) service
<i>Example</i>	Commands (e.g. Windows CMD commands)
Example	Database entry
[Example]	MobileKey type selection

4 Product description

The SmartOutput module features eight potential-free relay outputs, which can be actuated using SmartRelay Advanced. Depending on the transponder ID, one or several outputs can be activated for a programmable time interval. This assignment (profile) is freely programmable in LSM.

This means that the SmartOutput module is suitable for functions such as:

- Authorisation-dependent lift control
- Activation to open mail box systems

Up to fifteen modules can be connected to a SmartRelay if more than eight outputs are needed.

5 Before placing an order

5.1 SmartRelay

At least one SmartRelay is required to operate a SmartOutput module. To order a SmartRelay, read the manual concerned on the required SmartRelay or contact us (see Help and contact).

5.2 Determining the number of required modules

Up to fifteen external modules can be connected to a SmartRelay 3 Advanced. Each module can be configured separately from one another using the software.

Only four outputs are available on module 15 (up to 116 additional outputs in total).

5.3 Acquiring and configuring power supply units

SmartRelay and up to eight SmartOutput modules can be operated with a power supply unit. The power supply unit must be able to deliver a suitable output voltage (recommended: 12 V_{DC}) and provide sufficient current (see *Technical specifications* [▶ 23] for power input).

5.4 Determining installation technology and location

SmartOutput modules are fastened to DIN rails. SmartRelay are not usually fitted to DIN rails.

5.5 Cable types and routes

SmartOutput modules should be fitted in such a way that all cables can be installed without bending them too much.

5.6 installation outside

Modules are not designed for outdoor installation without additional protective measures.

5.7 Guidelines

Specialist trained to EN 18328 requirements should install the module. VDE guidelines must be observed.

6 Before installation

1. Unpack the SmartOutput module.
2. Check the SmartOutput module for external damage.
3. Connect the SmartOutput module and a reader to a SmartRelay.
4. Power the SmartOutput module.

IMPORTANT

Reverse polarity damages electronics

If you connect the power supply with the wrong polarity, the electronics will be damaged.

- Observe the polarity.

-
- ↳ SmartOutput module "rattles" when the power supply is connected.
 - ↳ SmartOutput module flashes red once every 16 seconds.
5. Power the SmartRelay.
 - ↳ SmartRelay detects SmartOutput module.
 - ↳ SmartOutput module flashes very quickly red/green for one second.
 - ↳ SmartOutput module has been detected and flashes green once every ten seconds.

7 Installation

- ✓ SmartOutput module tested (see *Before installation* [▶ 11]).
 - ✓ DIN rails available for installation.
1. Fit the SmartOutput module onto the DIN rail.
 2. Switch off the power supply.
 3. Connect all cables (see *Connections* [▶ 13]).
 4. Switch on the power supply.

IMPORTANT

Check polarity is correct.

-
5. Use the LSM software to programme the controller (see *Programming and configuration* [▶ 19]).
 6. Use authorised transponders to check the controller functions correctly.

8 Connections

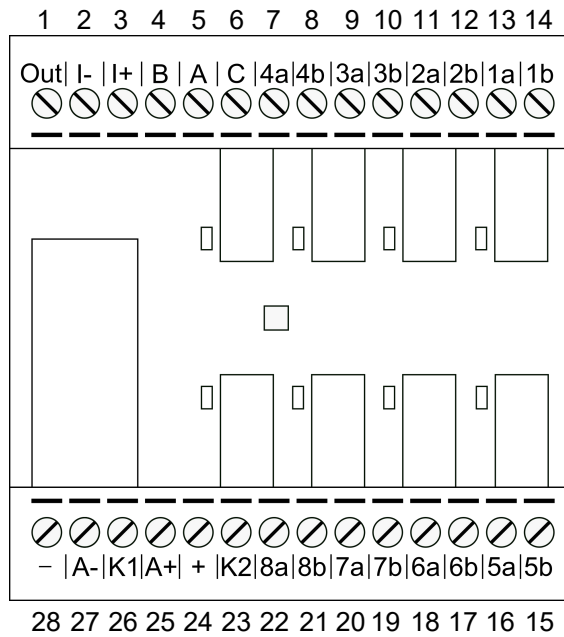

No.	Circuit board	Explanation
1	Out	<p>Brownout detection: Open collector, connected to GND if supply voltage is sufficient.</p> <p>This output activates if the supply voltage at V_{IN} falls below $10.0 V_{DC} (\pm 0.5 V_{DC})$. The earth connection is usually connected to the AUX relay's coil. If the supply voltage falls at V_{IN}, the AUX relay activates before the other relay contacts activate unchecked due to the decreasing voltage. When the supply voltage is applied, the output does not activate until the module has fully initialised and relay contacts can no longer switch unchecked.</p>
2	I-	Isolated digital input. Currently not in use.
3	I+	Isolated digital input. Currently not in use.
4	B	Controller connection: Data Line B; connected to contact for Reader 3.
5	A	Controller connection: Data Line A; connected to contact for Reader 3.
6	C	Controller connection: Earth; connected to contact for Reader 3.
7	4a	Relay 4: Potential-free contact (NC treated as NO in software); activated depending on authorisations.

No.	Circuit board	Explanation
8	4b	Relay 4: Potential-free contact (NC treated as NO in software); activated depending on authorisations.
9	3a	Relay 3: Potential-free contact (NC treated as NO in software); activated depending on authorisations.
10	3b	Relay 3: Potential-free contact (NC treated as NO in software); activated depending on authorisations.
11	2a	Relay 2: Potential-free contact (NC treated as NO in software); activated depending on authorisations.
12	2b	Relay 2: Potential-free contact (NC treated as NO in software); activated depending on authorisations.
13	1a	Relay 1: Potential-free contact (NC treated as NO in software); activated depending on authorisations.
14	1b	Relay 1: Potential-free contact (NC treated as NO in software); activated depending on authorisations.
15	5b	Relay 5: Potential-free contact (NC treated as NO in software); activated depending on authorisations.
16	5a	Relay 5: Potential-free contact (NC treated as NO in software); activated depending on authorisations.
17	6b	Relay 6: Potential-free contact (NC treated as NO in software); activated depending on authorisations.
18	6a	Relay 6: Potential-free contact (NC treated as NO in software); activated depending on authorisations.
19	7b	Relay 7: Potential-free contact (NC treated as NO in software); activated depending on authorisations.
20	7a	Relay 7: Potential-free contact (NC treated as NO in software); activated depending on authorisations.
21	8b	Relay 8: Potential-free contact (NC treated as NO in software); activated depending on authorisations.
22	8a	Relay 8: Potential-free contact (NC treated as NO in software); activated depending on authorisations.
23	K2	AUX relay: Potential-free contact (NO). Contact is connected with K1 (number 26) if coil is connected to power. Equipped with a detachable bridge to + (number 24) ex works.

No.	Circuit board	Explanation
24	+	V_{IN} . Connection for power supply. Equipped with a detachable bridge to K2 (number 23) ex works.
25	A+	AUX relay: Coil's plus connection. AUX relay activates if coil is connected to power. Equipped with a detachable bridge to K1 (number 26) ex works.
26	K1	AUX relay: Potential-free contact (normally open contact). Contact is connected with K2 (number 23) if coil is connected to power. Equipped with a detachable bridge to A+ (number 25) ex works.
27	A-	AUX relay: Coil's minus connection. AUX relay activates if coil is connected to power.
28	-	GND. Connection for power supply.

9 Connection to the SmartRelay

This is how you connect the SmartOutput module to a third-generation SmartRelay controller (SREL3.ADV or SREL3.ADV.ZK).

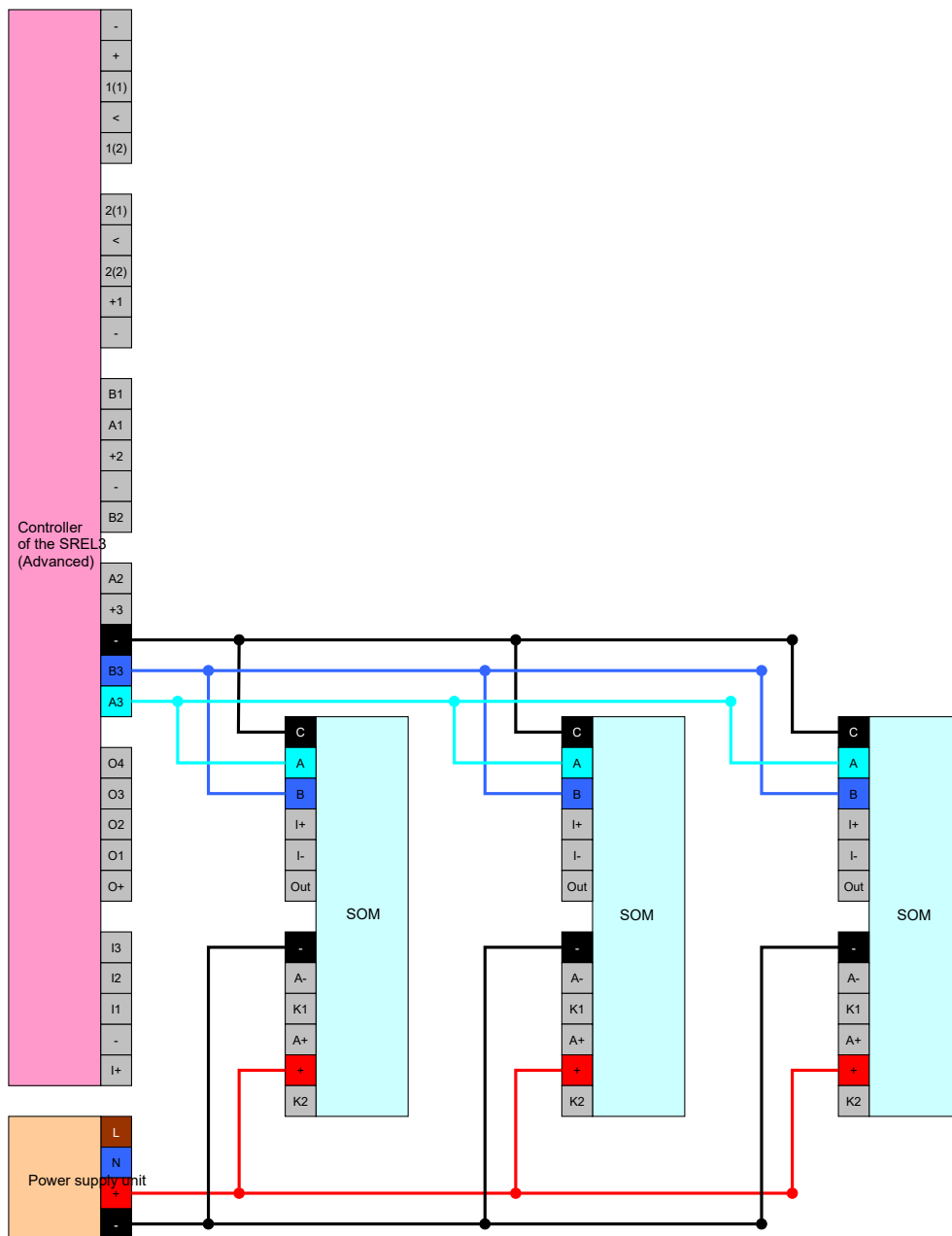

9.1 Standard power supply unit connection

This is how you connect a power supply unit to the SmartOutput module.

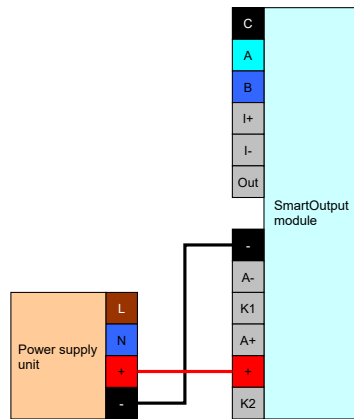

9.2 Connecting a fire alarm system emergency release

If the relay in the fire alarm system opens, this interrupts the SmartOutput module's power supply, closing Outputs 1 to 8.

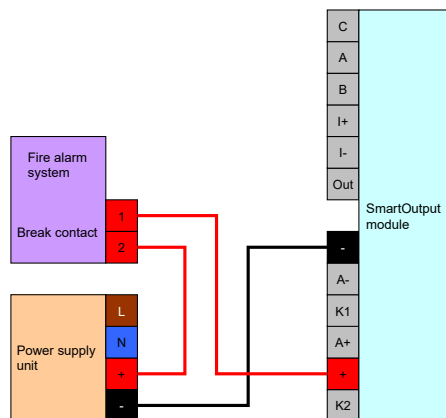

9.3 Circuit to prevent opening if power supply should fail

The AUX relay can be used in conjunction with the low voltage switching output (OUT) to prevent actuators, such as a buzzer or an electric strike, from switching of their own accord if the power supply to the SmartOutput module is interrupted. This ensures that actuators will not be powered and will not switch either if the SmartOutput module's power supply fails. This circuit is suitable for handling power supply failures in the SmartOutput module.

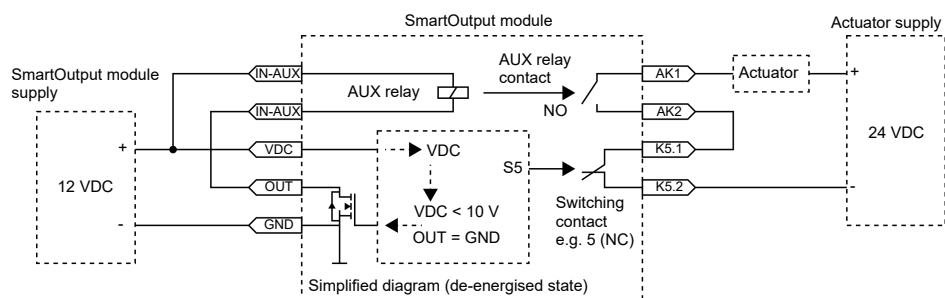

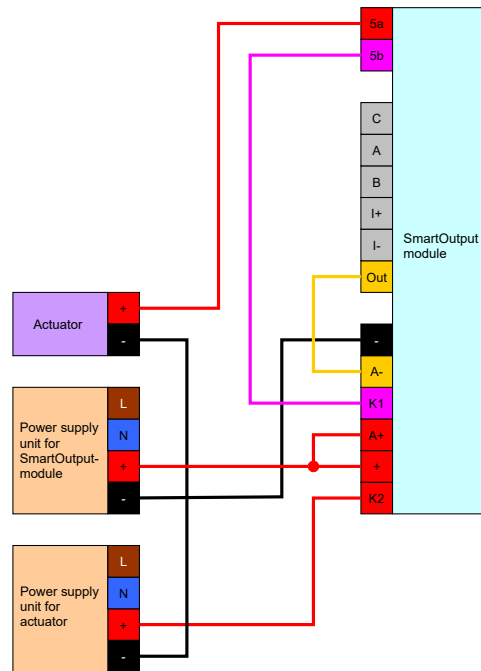

10 Programming and configuration

10.1 General information

1. Connect the SmartOutput module with a SmartRelay.
2. Connect the components to the power supply.
3. Programme the controller.



NOTE

The SmartOutput module can only be programmed on the controller.

10.2 Entering the number of modules

1. Double-click on the SmartRelay entry in the matrix to open the settings.
2. Change to the [Configuration/Data] tab.
3. Click on the **Extended configuration** button.
 - ↳ The "Extended configuration" window will open.
4. Enter the number of modules.
5. Click on the **OK** button.
 - ↳ Window closes.
6. Click on the **Apply** button.
7. Click on the **Exit** button.
8. Execute programming.
 - ↳ The number of modules is set.

10.3 Configuring the address for modules

Each connected module is actuated using its address. This address is set on the address switch. If you connect a SmartOutput module to a SmartRelay 3, set the following addresses:

Module	Address
Module 1	0 (initial setting in the factory)
Module 2	1
Module 3	2
Module 4	3
Module 5	4
Module 6	5
Module 7	6

Module	Address
Module 8	7
Module 9	8
Module 10	9
Module 11	A
Module 12	B
Module 13	C
Module 14	D
Module 15	E

1. Press the sides of the transparent inlay together.
2. Remove the transparent inlay.
3. Use a screwdriver to configure the address as per the table.
4. Insert the transparent inlay again.

10.4 Setting the pulse length

The pulse length for SREL3.ADV modules is identical to the pulse length configured in the controller (exception: pulse lengths < 3 s). It cannot be set for modules which an SREL3.ADV activates.

10.5 Naming in the software

The LSM software automatically issues names for modules when they are added based on the following convention: SmartRelay name + module address (0 to F) + output number (1 to 8).

Example: Lift_Mod#0_Out#4

You can also change the name as you wish.

1. Double-click on the entry in the matrix to open the properties of the output of which you wish to change the name.
 2. Change to the [Door] tab.
 3. Enter the new name.
 4. Click on the **Apply** button.
 5. Click on the **Exit** button.
- ↳ The output has now been renamed.

10.6 Inverting outputs

You can invert the switching behaviour of outputs.

IMPORTANT**Only invert when the power supply is connected**

If the power supply fails, the relay contacts on the SmartOutput module will also remain closed (NC) when switching behaviour has been inverted.

- Allow for a possible power supply failure if you invert the switching behaviour in outputs.

-
1. Double-click on the module entry in the matrix to open the properties.
 2. Change to the [Configuration/Data] tab.
 3. Enable the Invert outputs checkbox.
- ↳ Outputs are inverted.

11 Signal

11.1 LEDs for each output

Each of the eight outputs has an assigned LED. This LED indicates the output's status.

Green	Output closed
Off	Output open

11.2 Status LED

There is also a three-colour RGB LED which indicates the SmartOutput module's status.

Lights up green every five seconds	Communication with SmartRelay OK
Lights up red every five seconds	Communication with SmartRelay disrupted (e.g. bus line busy due to communication by other modules)
Flashes green/red	Communication is taking place with SmartRelay
Flashes red	Supply voltage too low

12 Technical specifications

Housing	
Material	<ul style="list-style-type: none"> ■ Housing: Polycarbonate plastic, fibre-reinforced ■ Cover: Polycarbonate plastic
Colour	<ul style="list-style-type: none"> ■ Housing: green similar to RAL 6021 (pale green) ■ Cover: transparent
Standard protection rating	IP20
Weight	~ 170 g (without packaging)
Installation	DIN rail (37 mm × 15 mm)
Power supply	
Screw terminals	<ul style="list-style-type: none"> ■ V_{IN}: 12 V_{DC} (11 V_{DC}–15 V_{DC}) ■ Standby current: < 120 mA ■ Max. current: < 150 mA ■ Reverse voltage protection: yes
Ambient conditions	
Temperature range	<ul style="list-style-type: none"> ■ 0 °C to +60 °C (operation) ■ 0 °C to +70 °C (in storage > 1 week)
Humidity	Max. 90%, non-condensing
Interfaces	
RS485	<p>Acts as an interface to the system controller.</p> <ul style="list-style-type: none"> ■ Number of ports: 1 ■ Length: ≤ 150 m, max. distance 300 m (depending on firmware and cabling)
Signal	
LED	1 RGB
	8 green
Relay	
Quantity	8x, programmable separately from one another
Switching modes	Monoflop
Switching interval	Programmable between 0 s to 25 s (as controller).
Contact type	1x NC

Contact material	AgNi+Au
Service life (electrics)	12 V _{DC} / 10 mA: typ. 5×10^7 switching cycles
Service life (mechanical)	Typically 100×10^6 switching cycles
Bounce time	Typically 1 ms, max. 3 ms
Vibrations	15 G for 11 ms, 6 shocks as per IEC 68-2-27; not tested for permanent operation under vibration
AUX relay switching voltage	Max. 24 V
AUX relay switching current	<ul style="list-style-type: none"> ■ Max. 1 A permanent current ■ Max. 2 A switching current
AUX relay contact type	1x NO
Switching voltage in outputs	Max. 24 V
Switching current in outputs	Max. 200 mA
OUT switching current	Max. 1 A
OUTPUT switching voltage	Max. 24 V
OUTPUT switching power	Max. 1 VA
OUT switching behaviour for low voltage	$U_V < 10.5 \pm 0.5V$ corresponds to off

Cable types

Lines with data transmission	Cat 5 or installation cable for telecommunications systems (e.g. F-YAY 2x2x0.6)
Lines with data transmission and power supply	Cat 5 or installation cable for telecommunications systems (e.g. F-YAY 2x2x0.6)
Lines for power supply only	Any line (e.g. F-YAY 2x2x0.6)

IMPORTANT**Take voltage drop into account**

The resistance in copper produces a voltage drop, the size of which depends on the cable gauge, current flow and cable length. The power supply lines must be adequately dimensioned.

1. Ensure that the cable gauge in lines is adequate for power supply. Use another suitable cable where necessary.
 2. If required, merge wire pairs to increase the cable gauge.
 3. Use a power source located closer to the SmartOutput module if needed.
 4. If possible, increase the supply voltage (observe technical specifications).
-

13 Declaration of conformity

The company SimonsVoss Technologies GmbH hereby declares that article MOD.SOM8 complies with the following guidelines:

- 2014/30/EU "EMC"
- 2011/65/EU "RoHS"
- 2012/19/EU "WEEE"
- and regulation (EG) 1907/2006 "REACH"

The full text of the EU Declaration of conformity is available at the following internet address: <https://www.simons-voss.com/en/certificates.html>.



14 Help and other information

Information material/documents

You will find detailed information on operation and configuration and other documents under Informative material/Documents in the Download section on the SimonsVoss website (<https://www.simons-voss.com/en/downloads/documents.html>).

Declarations of conformity

You will find declarations of conformity for this product in the Certificate section on the SimonsVoss website (<https://www.simons-voss.com/en/certificates.html>).

Information on disposal

- Do not dispose the device (MOD.SOM8) in the household waste. Dispose of it at a collection point for electronic waste as per European Directive 2012/19/EU.
- Recycle defective or used batteries in line with European Directive 2006/66/EC.
- Observe local regulations on separate disposal of batteries.
- Take the packaging to an environmentally responsible recycling point.



Hotline

If you have any questions, the SimonsVoss Service Hotline will be happy to help you on +49 (0)89 99 228 333 (German fixed network; call charges vary depending on the operator).

Email

You may prefer to send us an email.

support-simonsvoss@allegion.com (System 3060, MobileKey)

FAQs

You will find information and help for SimonsVoss products in the FAQ section on the SimonsVoss website (<https://faq.simons-voss.com/otrs/public.pl>).

Address

SimonsVoss Technologies GmbH
Feringastrasse 4
85774 Unterföhring
Germany



This is SimonsVoss

SimonsVoss is a technology leader in digital locking systems.

The pioneer in wirelessly controlled, cable-free locking technology delivers system solutions with an extensive product range for SOHOs, SMEs, major companies and public institutions.

SimonsVoss locking systems unite intelligent functions, optimum quality and award-winning German-made design. As an innovative system provider, SimonsVoss attaches great importan-

ce to scalable systems, effective security, reliable components, high-performance software and simple operation.

Our commercial success lies in the courage to innovate, sustainable thinking and action, and heartfelt appreciation of employees and partners. With its headquarters in Unterföhring, near Munich, and its production site in Osterfeld, eastern Germany, the company employs around 300 staff in eight countries.

SimonsVoss is a company in the ALLEGION Group, a globally active network in the security sector. Allegion is represented in around 130 countries worldwide (www.allegion.com).

© 2020, SimonsVoss Technologies GmbH, Unterföhring

All rights are reserved. Text, images and diagrams are protected under copyright law.

The content of this document must not be copied, distributed or modified. More information about this product can be found on the SimonsVoss website. Subject to technical changes.

SimonsVoss and MobileKey are registered brands belonging to SimonsVoss Technologies GmbH.

