

30
60



DE	Kurzanleitung
EN	Quick Guide
FR	Guide abrégé
NL	Korte handleiding
IT	Guida breve
DK	Kort vejledning
SE	Snabbguide

Anti-vandalism housing

SR27.030200

09.02.2023

Abbildungen/Images	3
deutsch	14
english	21
français	28
nederlands	35
italiano	42
dansk	49
svensk	56

4. Installation



PZ2



SW3



STX10

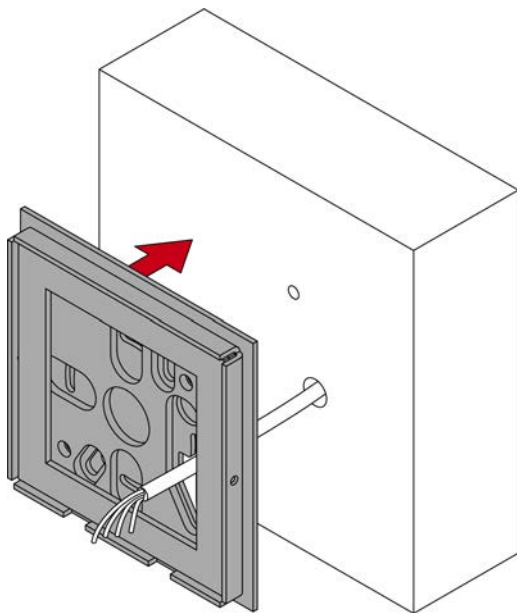

2



PZ2

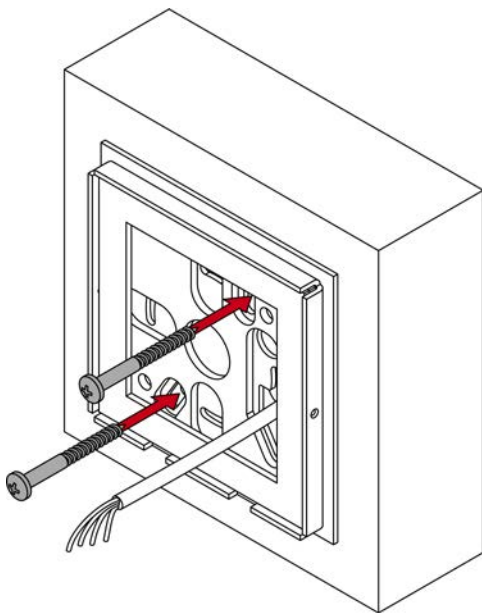



3

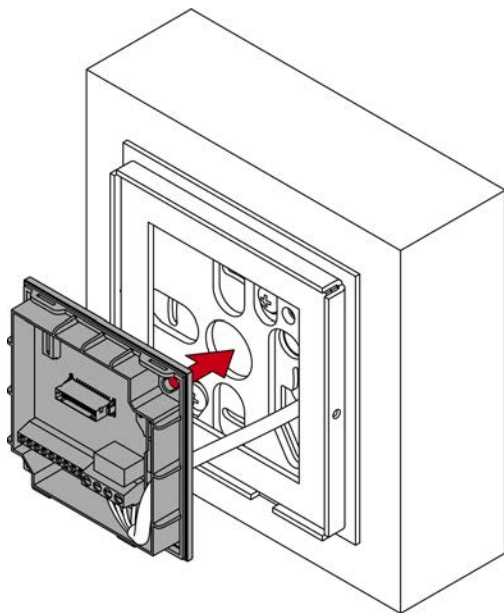

4



SW3

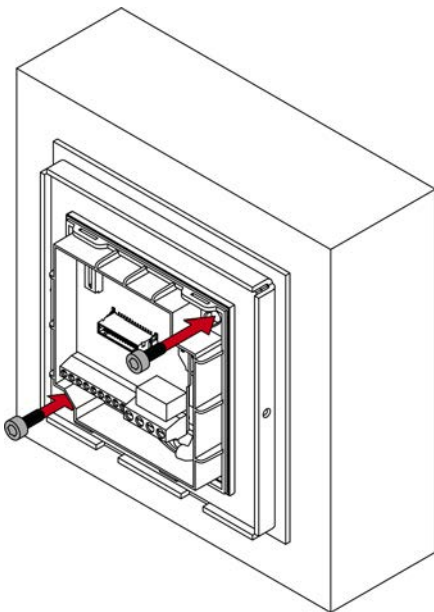



5

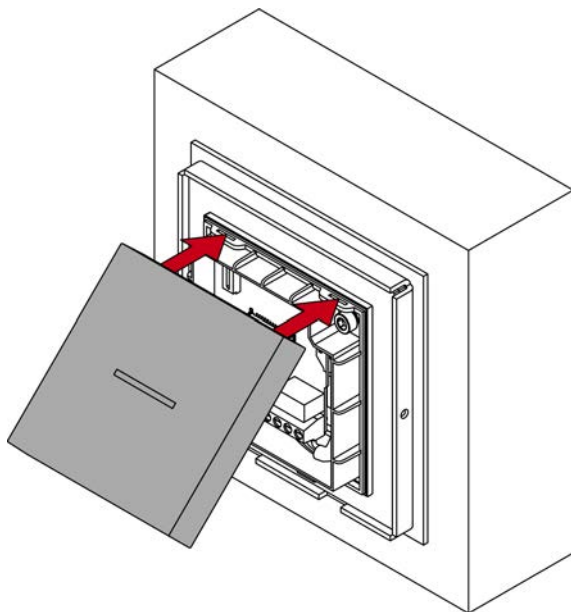

6

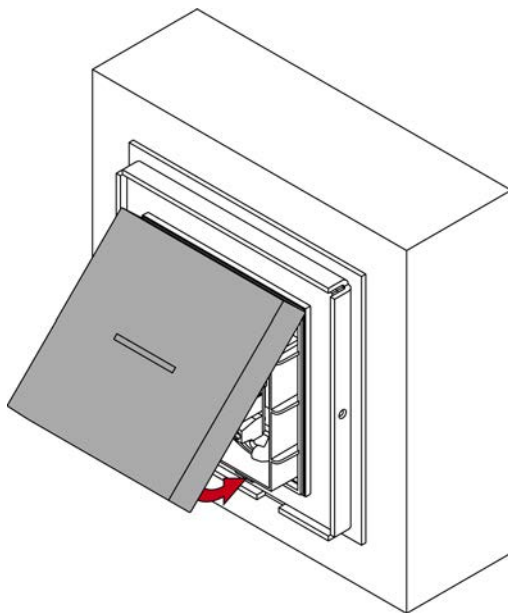

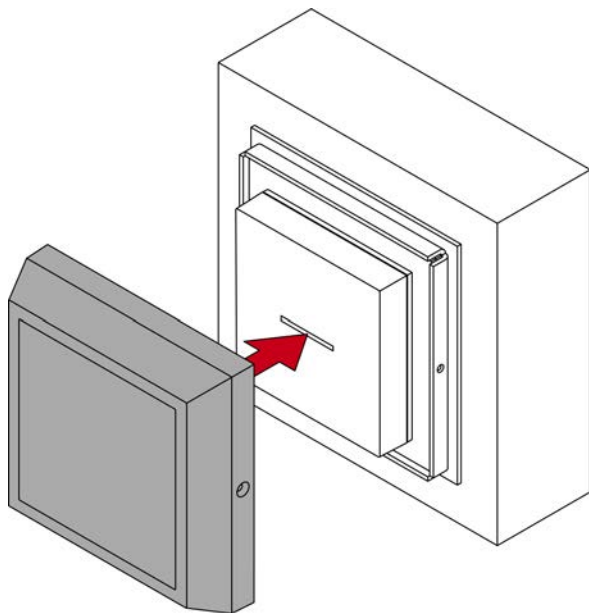

8



STX10

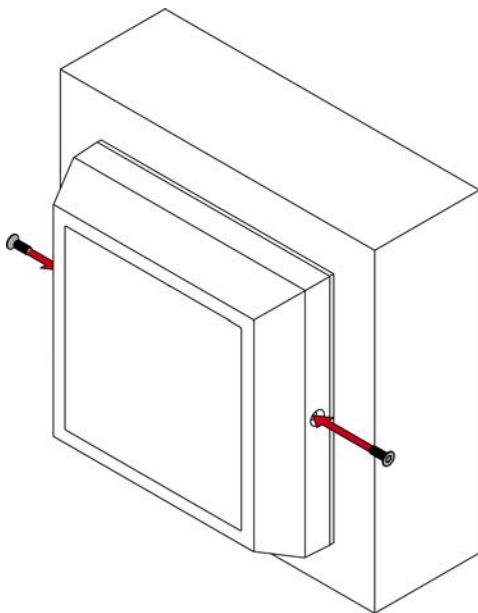



9

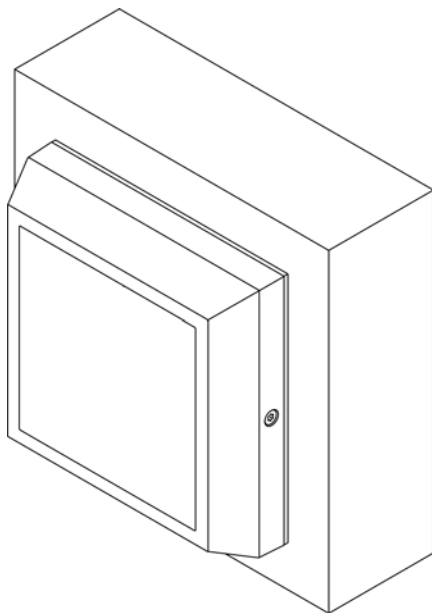

5. Technical data



10

Inhaltsverzeichnis

1	Allgemeine Sicherheitshinweise	15
2	Bestimmungsgemäße Verwendung	17
3	Lieferumfang	17
4	Montage	18
5	Technische Daten	19
6	Hilfe und weitere Informationen	20

1 Allgemeine Sicherheitshinweise

Signalwörter
(ANSI
Z535.6)

Gefahr: Tod oder schwere Verletzung (wahrscheinlich), Warnung: Tod oder schwere Verletzung (möglich, aber unwahrscheinlich), Vorsicht: Leichte Verletzung, Achtung: Sachschäden oder Fehlfunktionen, Hinweis: Geringe oder keine Schäden



WARNUNG

Versperrter Zugang

Durch fehlerhaft montierte und/oder programmierte Komponenten kann der Zutritt durch eine Tür versperrt bleiben. Für Folgen eines versperrten Zutritts wie Zugang zu verletzten oder gefährdeten Personen, Sachschäden oder anderen Schäden haftet die SimonsVoss Technologies GmbH nicht!

Versperrter Zugang durch Manipulation des Produkts

Wenn Sie das Produkt eigenmächtig verändern, dann können Fehlfunktionen auftreten und der Zugang durch eine Tür versperrt werden.

- Verändern Sie das Produkt nur bei Bedarf und nur in der Dokumentation beschriebenen Art und Weise.

ACHTUNG**Beschädigung durch Öle, Fette, Farben und Säuren**

Dieses Produkt enthält elektronische und/oder mechanische Bauteile, die durch Flüssigkeiten aller Art beschädigt werden können.

- Halten Sie Öle, Fette, Farben und Säuren vom Produkt fern.

Beschädigung durch aggressive Reinigungsmittel

Die Oberfläche dieses Produkts kann durch ungeeignete Reinigungsmittel beschädigt werden.

- Verwenden Sie ausschließlich Reinigungsmittel, die für Kunststoff- bzw. Metalloberflächen geeignet sind.

**HINWEIS****Bestimmungsgemäßer Gebrauch**

SimonsVoss-Produkte sind ausschließlich für das Öffnen und Schließen von Türen und vergleichbaren Gegenständen bestimmt.

- Verwenden Sie SimonsVoss-Produkte nicht für andere Zwecke.

Qualifikationen erforderlich

Die Installation und Inbetriebnahme setzt Fachkenntnisse voraus.

- Nur geschultes Fachpersonal darf das Produkt installieren und in Betrieb nehmen.

Änderungen bzw. technische Weiterentwicklungen können nicht ausgeschlossen und ohne Ankündigung umgesetzt werden.

Die deutsche Sprachfassung ist die Originalbetriebsanleitung. Andere Sprachen (Abfassung in der Vertragssprache) sind Übersetzungen der Originalbetriebsanleitung.

Lesen Sie alle Anweisungen zur Installation, zum Einbau und zur Inbetriebnahme und befolgen Sie diese. Geben Sie diese Anweisungen und jegliche Anweisungen zur Wartung an den Benutzer weiter.

2 Bestimmungsgemäße Verwendung

Das SREL2.COVER1 ist ein Vandalismusschutzgehäuse. Damit können Sie Ihr Gerät auch im Außenbereich einsetzen und vor mechanischen und witterungsbedingten Beschädigungen schützen.

Folgende Geräte sind kompatibel:



- SREL2 im weißen Designgehäuse (SREL2.*; MK.SREL2.*)
- Externe Kartenleser für SREL2 (SC.M.E.G2.W(.WP))
- Leser für SREL3 (SREL3.EXT.G2.W(.WP))







3 Lieferumfang

- 1× Vandalismusschutzgehäuse, bestehend aus Bodenplatte, Rahmen und Deckel
- 2× Sicherheitsschraube mit Secutorx-10-Antrieb (vormontiert)
- 1× Secutorx-10-Schraubertbit

- 2× A2-Innensechskantschraube (DIN 912 M4x8 mm, SW3, vormontiert)
- 2× A2-Halbrundkopfschraube (DIN 7996 5x50 mm, PZ2)
- 2× Dübel (Fischer SX8)

4 Montage

- ✓ Wand vorgebohrt.
 - ✓ SmartRelais geöffnet.
 - ✓ PZ2-Schraubendreher vorhanden.
 - ✓ SW3-Schraubendreher vorhanden.
 - ✓ Secutorx-10-Schraubendreher vorhanden.
1. Legen Sie die Edelstahlplatte an der Wand an.
 1
 2. Schrauben Sie die Edelstahlplatte mit einem PZ2-Schraubendreher fest. Verwenden Sie ggfs. geeignete Dübel.
 2
 3. Führen Sie das Kabel durch die Bodenplatte des SmartRelais und schließen Sie das SmartRelais an.
 4. Legen Sie die Bodenplatte des SmartRelais an der Edelstahlplatte an.
 3

5. Schrauben Sie die Bodenplatte des SmartRelais mit einem SW3-Schraubendreher fest.
 4
 6. Setzen Sie den Deckel des SmartRelais an der Bodenplatte an.
 5
 7. Schließen Sie den Deckel des SmartRelais.
 6
 8. Setzen Sie den Deckel des Vandalismusschutzgehäuses auf die Edelstahlplatte.
 7
 9. Drücken Sie den Deckel des Vandalismusschutzgehäuses gegen die Wand und schrauben Sie mit dem Secutorx-10-Schraubendreher den Deckel fest.
 8
- ↳ SmartRelais und Vandalismusschutzgehäuse montiert.
 9

5 Technische Daten

Abmessungen (B×H×T)	111,3 mm × 111,3 mm × 30,7 mm
Schutzart	IP54
Material	<ul style="list-style-type: none">■ Rahmen: ABS (PA6 50% glasfaserverstärkt)■ Bodenplatte: V2A-Edelstahl

Farbe	<ul style="list-style-type: none">■ Rahmen: Eisengrau, ähnlich RAL 7011■ Deckel: Transparent■ Bodenplatte: Edelstahl
-------	--



10

6 Hilfe und weitere Informationen

Infomaterial/ <https://www.simons-voss.com/de/dokumente.html>

Dokumente

Technischer +49 (0) 89 / 99 228 333

Support

E-Mail support-simonsvoss@allegion.com

FAQ <https://faq.simons-voss.com/otrs/public.pl>

SimonsVoss Technologies GmbH, Feringastr. 4, D-85774 Unterfoehring,
Deutschland

Contents

1	General safety instructions.....	22
2	Appropriate use.....	24
3	Scope of delivery.....	24
4	Installation.....	24
5	Technical data.....	26
6	Help and other information.....	26

1 General safety instructions

Signal words DANGER: Death or serious injury (likely), WARNING: Death or serious injury (possible, but unlikely), PRUDENCE: Minor injury, IMPORTANT: Property damage or malfunction, NOTE: Low or no damage
(ANSI Z535.6)



WARNING

Blocked access

Access through a door may stay blocked due to incorrectly fitted and/or incorrectly programmed components. SimonsVoss Technologies GmbH is not liable for the consequences of blocked access such as access to injured or endangered persons, material damage or other damage!

Blocked access through manipulation of the product

If you change the product on your own, malfunctions can occur and access through a door can be blocked.

- Modify the product only when needed and only in the manner described in the documentation.

IMPORTANT

Damage resulting from liquids

This product contains electronic and/or mechanic components that may be damaged by liquids of any kind.

- Keep liquids away from the electronics.

Damage resulting from aggressive cleaning agents

The surface of this product may be damaged as a result of the use of unsuitable cleaning agents.

- Only use cleaning agents that are suitable for plastic or metal surfaces.
-



NOTE

Intended use

SimonsVoss-products are designed exclusively for opening and closing doors and similar objects.

- Do not use SimonsVoss products for any other purposes.

Qualifications required

The installation and commissioning requires specialized knowledge.

- Only trained personnel may install and commission the product.

Modifications or further technical developments cannot be excluded and may be implemented without notice.

The German language version is the original instruction manual. Other languages (drafting in the contract language) are translations of the original instructions.

Read and follow all installation, installation, and commissioning instructions. Pass these instructions and any maintenance instructions to the user.

2 Appropriate use

The SREL2.COVER1 is an anti-vandalism housing. It allows you to use your device outdoors and protect it from mechanical and weather-related damage.

The following devices are compatible:







- SREL2 in white design housing (SREL2.*; MK.SREL2.*)
- External card reader for SREL2 (SC.M.E.G2.W[.WP])
- Reader for SREL3 (SREL3.EXT.G2.W[.WP])

3 Scope of delivery

- 1× anti-vandalism housing, consisting of base plate, frame and cover
- 2× safety screws with Secutorx 10 drive (pre-assembled)
- 1× Secutorx 10 screwdriver bit
- 2× A2 hexagon socket head screws (DIN 912 M4x8 mm, AF3, pre-assembled)
- 2× A2 button head screws (DIN 7996 5x50 mm, PH2)
- 2× dowels (Fischer SX8)

4 Installation

- ✓ Wall pre-drilled.

- ✓ SmartRelay opened.
 - ✓ PZ2 screwdriver at hand.
 - ✓ AF3 screwdriver at hand.
 - ✓ Secutorx 10 screwdriver at hand.
1. Place the stainless steel plate on the wall.
 1
 2. Screw the stainless steel plate into position with a PH2 screwdriver.
Use suitable dowels if necessary.
 2
 3. Feed the cable through the SmartRelay base plate and connect the SmartRelay.
 4. Place the SmartRelay base plate on the stainless steel plate.
 3
 5. Screw the SmartRelay base plate into position firmly using an AF3 screwdriver.
 4
 6. Place the SmartRelay cover on the base plate.
 5
 7. Close the SmartRelay cover.
 6
 8. Place the anti-vandalism housing cover on the stainless steel plate.
 7

9. Press the anti-vandalism housing cover against the wall and screw the cover into position firmly with the Secutorx 10 screwdriver.



8

- ↳ SmartRelay and anti-vandalism housing installed.



9

5 Technical data

Dimensions (W×H×D)	111.3 mm × 111.3 mm × 30.7 mm
Protection rating	IP54
Material	<ul style="list-style-type: none"> ■ Frame: ABS (PA6 50% glass-fibre reinforced) ■ Base plate: V2A stainless steel
Colour	<ul style="list-style-type: none"> ■ Frame: iron grey, similar to RAL 7011 ■ Cover: transparent ■ Base plate: stainless steel



10

6 Help and other information

Information
material/doc-
uments

<https://www.simons-voss.com/en/documents.html>

Technical support +49 (0) 89 / 99 228 333

Email support-simonsvoss@allegion.com

FAQs <https://faq.simons-voss.com/otrs/public.pl>

SimonsVoss Technologies GmbH, Feringastr. 4, D-85774 Unterfoehring, Germany

Tables des matières

1	Consignes de sécurité générales	29
2	Utilisation appropriée.....	31
3	Fourniture	31
4	Montage.....	32
5	Caractéristiques techniques	33
6	Aide et autres informations.....	34

1 Consignes de sécurité générales

Mots indicateurs (ANSI Z535.6)

DANGER: Mort ou blessure grave (probable), AVERTISSEMENT: Mort ou blessure grave (possible, mais improbable), ATTENTION: Blessure légère, ATTENTION: Dommages matériels ou dysfonctionnements, REMARQUE: Peu ou pas dommage



AVERTISSEMENT

Accès bloqué

Toute erreur de montage et/ou de programmation d'un composant peut bloquer l'accès par une porte. La société SimonsVoss Technologies GmbH décline toute responsabilité quant aux conséquences d'un accès bloqué, par exemple, accès pour les personnes blessées ou en danger, dommages matériels ou autres dommages !

Accès bloqué par la manipulation du produit

Si vous modifiez vous-même le produit, des dysfonctionnements peuvent se produire et l'accès peut être bloqué par une porte.

- Ne changer le produit que lorsque cela est nécessaire et de la manière décrite dans la documentation.

ATTENTION**Endommagement lié à des liquides**

Ce produit contient des composants électroniques et/ou mécaniques susceptibles d'être endommagés par tout type de liquide.

- Tenez les liquides à l'écart du système électronique.

Endommagement lié à des nettoyants agressifs

La surface de ce produit peut être endommagée par des nettoyants inappropriés.

- Utilisez exclusivement des nettoyants adaptés aux surfaces plastiques ou métalliques.

REMARQUE**Utilisation conforme aux dispositions**

Les produits SimonsVoss sont exclusivement destinés à l'ouverture et la fermeture de portes et d'objets similaires.

- N'utilisez pas les produits SimonsVoss à d'autres fins.

Qualifications requises

L'installation et la mise en service nécessitent des connaissances spécialisées.

- Seul le personnel qualifié peut installer et mettre en service le produit.

Les modifications et nouveaux développements techniques ne peuvent pas être exclus et peuvent être mis en œuvre sans préavis.

La version allemande est le manuel d'instruction original. Les autres langues (rédaction dans la langue du contrat) sont des traductions des instructions originales.

Lisez et suivez toutes les instructions d'installation, d'installation et de mise en service. Transmettez ces instructions et toutes les instructions de maintenance à l'utilisateur.

2 Utilisation appropriée

Le SREL2.COVER1 est un boîtier anti-effraction. Grâce à ce boîtier, vous pouvez utiliser votre appareil à l'extérieur et le protéger contre les dommages mécaniques et les intempéries.

Les appareils suivants sont compatibles :

- SREL2 dans le boîtier design blanc (SREL2.* ; MK.SREL2.*)
- Lecteur de cartes externe pour SREL2 (SC.M.E.G2.W(.WP))
- Lecteur pour SREL3 (SREL3.EXT.G2.W(.WP))

3 Fourniture

- 1× boîtier anti-effraction, composé d'une plaque de base, d'un cadre et d'un couvercle
- 2× vis de sécurité avec entraînement Secutorx-10 (prémontées)
- 1× embout de vissage Secutorx-10
- 2× vis à six pans creux A2 (DIN 912 M4 x 8 mm, SW3, prémontées)
- 2× vis à tête ronde A2 (DIN 7996 5 x 50 mm, PZ2)
- 2× chevilles (Fischer SX8)

4 Montage

- ✓ Mur prépercé.
- ✓ SmartRelais ouvert.
- ✓ Tournevis PZ2 disponible.
- ✓ Tournevis SW3 disponible.
- ✓ Tournevis Secutorx-10 disponible.

1. Placez la plaque en acier inoxydable contre le mur.



2. Vissez la plaque en acier inoxydable au moyen d'un tournevis PZ2. Utilisez au besoin des chevilles adaptées.



3. Guidez le câble à travers la plaque de base du SmartRelais et raccordez ce dernier.

4. Placez la plaque de base du SmartRelais contre la plaque en acier inoxydable.



5. Vissez la plaque de base du SmartRelais au moyen d'un tournevis SW3.



6. Placez le couvercle du SmartRelais contre la plaque de base.



7. Fermez le couvercle du SmartRelais.



8. Placez le couvercle du boîtier anti-effraction sur la plaque en acier inoxydable.



7

9. Poussez le couvercle du boîtier anti-effraction contre le mur et vissez-le au moyen du tournevis Secutorx-10.



8

- ↳ SmartRelais et boîtier anti-effraction monté.



9

5 Caractéristiques techniques

Dimensions (l × H × P)	111,3 mm × 111,3 mm × 30,7 mm
Classe de protection	IP54
Matériau	<ul style="list-style-type: none"> ■ Cadre : ABS (PA6 renforcé de 50 % de fibre de verre) ■ Plaque de base : acier inoxydable V2A
Couleur	<ul style="list-style-type: none"> ■ Cadre : Gris fer, semblable au RAL 7011 ■ Couvercle : Transparent ■ Plaque de base : Acier inoxydable



10

6 Aide et autres informations

Documenta-
tion/docu-
ments <https://www.simons-voss.com/fr/documents.html>

Assistance
technique +49 (0) 89 / 99 228 333

E-Mail support-simonsvoss@allegion.com

FAQ <https://faq.simons-voss.com/otrs/public.pl>

SimonsVoss Technologies GmbH, Feringastr. 4, D-85774 Unterfoehring,
Allemagne

Inhoudsopgave

1	Algemene veiligheidsinstructies	36
2	Passend gebruik	38
3	Leveromvang.....	38
4	Montage.....	39
5	Technische gegevens	40
6	Hulp en verdere informatie	41

1 Algemene veiligheidsinstructies

Signaalwoorden (ANSI Z535.6)

GEVAAR: Dood of ernstig letsel (waarschijnlijk), WAARSCHUWING: Dood of ernstig letsel (mogelijk, maar onwaarschijnlijk), VOORZICHTIG: Lichte verwonding, LET OP: Materiële schade of storing, OPMERKING: Laag of nee schade



WAARSCHUWING

Geblokkeerde toegang

Door foutief geïnstalleerde en/of geprogrammeerde componenten kan de doorgang door een deur geblokkeerd blijven. Voor gevolgen van een geblokkeerde toegang tot gewonden of personen in gevaar, materiële of andere schade, is SimonsVoss Technologies GmbH niet aansprakelijk.

Geblokkeerde toegang als gevolg van manipulatie van het product

Als u het product zelf wijzigt, kunnen er storingen optreden en kan de toegang worden geblokkeerd door een deur.

- Vervang het product alleen wanneer dat nodig is en op de manier die in de documentatie wordt beschreven.

LET OP**Beschadiging door vloeistoffen**

Dit product heeft elektronische en/of mechanische componenten die kunnen worden beschadigd door elk type vloeistof.

- Houd vloeistoffen uit de buurt van de elektronica.

Beschadiging door bijtende reinigingsmiddelen

Het oppervlak van dit product kan worden beschadigd door ongeschikte reinigingsmiddelen.

- Maak uitsluitend gebruik van reinigingsmiddelen die geschikt zijn voor kunststof of metalen oppervlakken.

**OPMERKING****Beoogd gebruik**

SimonsVoss-producten zijn uitsluitend bedoeld voor het openen en sluiten van deuren en vergelijkbare voorwerpen.

- Gebruik SimonsVoss-producten niet voor andere doeleinden.

Kwalificaties vereist

De installatie en inbedrijfstelling vereist gespecialiseerde kennis. Alleen getraind personeel mag het product installeren en in bedrijf stellen.

Aanpassingen of nieuwe technische ontwikkelingen kunnen niet uitgesloten worden en worden gerealiseerd zonder aankondiging.

De Duitse taalversie is de originele handleiding. Andere talen (opstellen in de contract-taal) zijn vertalingen van de originele instructies.

Lees en volg alle installatie-, installatie- en inbedrijfstellingsinstructies. Geef deze instructies en eventuele onderhoudsinstructies door aan de gebruiker.

2 Passend gebruik

De SREL2.COVER1 is een vandalismebestendige behuizing. Daarmee kunt u uw apparaat ook buiten gebruiken en beschermen tegen mechanische beschadigingen en schadelijke weersinvloeden.

De volgende apparaten zijn compatibel:



- SREL2 in witte designbehuizing (SREL2.*; MK.SREL2.*)
- externe kaartlezer voor SREL2 (SC.M.E.G2.W(.WP))
- lezer voor SREL3 (SREL3.EXT.G2.W(.WP))

3 Leveromvang

- 1× vandalismebestendige behuizing, bestaande uit bodemplaat, frame en deksel
- 2× veiligheidsschroef met Secutorx-10-aandrijving (voorgemonteerd)
- 1× Secutorx-10-schroevendraaierbit
- 2× A2-inbusschroef (DIN 912 M4x8 mm, SW3, voorgemonteerd)

- 2× A2-schroef met halfronde kop (DIN 7996 5x50 mm, PZ2)
- 2× pluggen (Fischer SX8)

4 Montage

- ✓ Voorgeboorde wand.
 - ✓ SmartRelais geopend.
 - ✓ PZ2-schroevendraaier beschikbaar.
 - ✓ SW3-schroevendraaier beschikbaar.
 - ✓ Secutorx-10-schroevendraaier beschikbaar.
1. Plaats de plaat van edelstaal tegen de muur.
 1
 2. Schroef de plaat van edelstaal vast met een PZ2-schroevendraaier. Gebruik indien nodig geschikte pluggen.
 2
 3. Leid de kabel door de bodemplaat van het SmartRelais en sluit het SmartRelais aan.
 4. Leg de bodemplaat van het SmartRelais tegen de plaat van edelstaal.
 3
 5. Schroef de bodemplaat van het SmartRelais vast met een SW3-schroevendraaier.
 4

6. Zet het deksel van het SmartRelais tegen de bodemplaat aan.
 5
 7. Sluit het deksel van het SmartRelais.
 6
 8. Plaats het deksel van de vandalismebestendige behuizing op de plaat van edelstaal.
 7
 9. Druk het deksel van de vandalismebestendige behuizing tegen de wand en schroef het met de Secutorx-10-schroevendraaier vast.
 8
- ↳ SmartRelais en vandalismebestendige behuizing gemonteerd.
 9

5 Technische gegevens

Afmetingen (B×H×D)	111,3 mm × 111,3 mm × 30,7 mm
Beschermingsgraad	IP54
Materiaal	<ul style="list-style-type: none">■ Frame: ABS (PA6 50% versterkt met glasvezel)■ Bodemplaat: V2A-edelstaal

Kleur	<ul style="list-style-type: none">■ Frame: IJzergrijs, vergelijkbaar met RAL 7011■ Deksel: doorzichtig■ Bodemplaat: edelstaal
-------	---



10

6 Hulp en verdere informatie

Informatie-
materiaal/do-
cumenten <https://www.simons-voss.com/nl/documenten.html>

Technische
Support +49 (0) 89 / 99 228 333

E-mail support-simonsvoss@allegion.com

FAQ <https://faq.simons-voss.com/otrs/public.pl>

SimonsVoss Technologies GmbH, Feringastr. 4, 85774 Unterföhring,
Duitsland

Sommarior

1	Avvisi di sicurezza generali.....	43
2	Uso appropriato	45
3	Oggetto di fornitura.....	45
4	Montaggio	46
5	Dati tecnici	47
6	Supporto e ulteriori informazioni	48

1 Avvisi di sicurezza generali

Avvertenze
(ANSI
Z535.6)

PERICOLO: Morte o lesioni gravi (probabile), AVVERTENZA: Morte o lesioni gravi (possibili, ma improbabili), ATTENZIONE: Lieve ferita, AVVISO: Danni materiali o malfunzionamento, NOTA: Basso o no



AVVERTENZA

Accesso bloccato

Con componenti montati e/o programmati in modo difettoso, l'accesso attraverso una porta può restare bloccato. La SimonsVoss Technologies GmbH non risponde delle conseguenze di un accesso bloccato, per esempio nel caso si debba accedere a persone ferite o in pericolo, di danni a cose o altri danni!

Accesso bloccato tramite manipolazione del prodotto

Se si modifica il prodotto da solo, possono verificarsi malfunzionamenti e l'accesso attraverso una porta può essere bloccato.

- Modificare il prodotto solo quando necessario e solo nel modo descritto nella documentazione.

AVVISO

Danni dovuti a fluidi

Il presente prodotto contiene componenti elettronici e/o meccanici che potrebbero subire danni dovuti a liquidi di qualunque tipo.

- Tenere i componenti elettronici lontani da liquidi.

Danni dovuti a detergenti aggressivi

La superficie di questo prodotto può essere danneggiata da detergenti non idonei.

- Utilizzare esclusivamente detergenti adatti a superfici in plastica o metallo.



NOTA

Uso conforme

I prodotti SimonsVoss sono concepiti esclusivamente per l'apertura e la chiusura di porte e oggetti simili.

- Non utilizzare i prodotti SimonsVoss per altri scopi.

Qualifiche richieste

L'installazione e la messa in servizio richiedono conoscenze specialistiche.

- Solo personale qualificato può installare e mettere in servizio il prodotto.

Non si escludono modifiche o perfezionamenti tecnici, anche senza preavviso.

La versione in lingua tedesca è il manuale di istruzioni originale. Altre lingue (redazione nella lingua del contratto) sono traduzioni delle istruzioni originali.

Leggere e seguire tutte le istruzioni di installazione, installazione e messa in servizio. Passare queste istruzioni e tutte le istruzioni di manutenzione all'utente.

2 Uso appropriato

SREL2.COVER1 è un alloggiamento di protezione antivandalismo, che consente di impiegare il proprio dispositivo anche all'aperto, proteggendolo dagli eventuali danni meccanici e causati da condizioni climatiche avverse.

I seguenti dispositivi sono compatibili:

- SREL2 in alloggiamento di design bianco (SREL2.*; MK.SREL2.*)
- Lettore di schede esterno per SREL2 (SC.M.E.G2.W(.WP))
- Lettore per SREL3 (SREL3.EXT.G2.W(.WP))

3 Oggetto di fornitura

- 1× alloggiamento di protezione antivandalismo, composto da piastra di base, telaio e coperchio
- 2× vite di sicurezza con drive Secutorx-10 (premontato)
- 1× punta cacciavite Secutorx-10
- 2× vite a testa esagonale A2 (DIN 912 M4x8 mm, SW3, premontata)
- 2× vite a testa bombata A2 (DIN 7996 5x50 mm, PZ2)
- 2× tassello (Fischer SX8)

4 Montaggio

- ✓ Parete già forata.
 - ✓ SmartRelè aperto.
 - ✓ Cacciavite PZ2 a disposizione.
 - ✓ Cacciavite SW3 a disposizione.
 - ✓ Cacciavite Secutorx-10 a disposizione.
1. Applicare la piastra in acciaio inox alla parete.



2. Avvitare saldamente la piastra in acciaio inox con un cacciavite PZ2. Utilizzare ev. tasselli idonei.



3. Passare il cavo attraverso la piastra di base dello SmartRelè e collegare lo SmartRelè.

4. Applicare la piastra di base dello SmartRelè alla piastra in acciaio inox.



5. Avvitare saldamente la piastra di base dello SmartRelè con un cacciavite SW3.



6. Posizionare il coperchio dello SmartRelè sulla piastra di base.



7. Chiudere il coperchio dello Smart Relè.



8. Posizionare il coperchio del dispositivo di protezione antivandalismo sulla piastra in acciaio inox.



7

9. Premere il coperchio del dispositivo di protezione antivandalismo contro la parete e avvitarlo saldamente con il cacciavite Secu-torx-10.



8

- ↳ SmartRelè e alloggiamento di protezione antivandalismo montati.



9

5 Dati tecnici

Dimensioni (L x A x P)	111,3 mm × 111,3 mm × 30,7 mm
Grado di protezione	IP54
Materiale	<ul style="list-style-type: none"> ■ Telaio: ABS (PA6 50% rinforzato con fibra di vetro) ■ Piastra di base: acciaio inox V2A
Colore	<ul style="list-style-type: none"> ■ Telaio: grigio ferro, simile a RAL 7011 ■ Coperchio: trasparente ■ Piastra di base: acciaio inox



10

6 Supporto e ulteriori informazioni

Materiale informativo/ <https://www.simons-voss.com/it/documenti.html>

Documenti

Supporto tecnico +49 (0) 89 / 99 228 333

E-mail support-simonsvoss@allegion.com

FAQ <https://faq.simons-voss.com/otrs/public.pl>

SimonsVoss Technologies GmbH, Feringastr. 4, D-85774 Unterfoehring,
Germania

Indholdsfortegnelse

1	Generelle sikkerhedshenvisninger.....	50
2	Tilsløget brug	52
3	Leveringsomfang	52
4	Montering	52
5	Tekniske data	54
6	Hjælp og flere oplysninger	54

1 Generelle sikkerhedshenvisninger

Signalord
(ANSI
Z535.6)

FARE: Død eller allvarlig personskada (troligt), ADVARSEL: Død eller allvarlig skada (møjligt, men osannolikt), FORSIGTIG: Liten skada, OPMÆRKSOMHED: Skador på egendom eller fel, BEMÆRK: Låg eller ingen



ADVARSEL

Spærret adgang

Hvis komponenter er fejlagtigt monteret og/eller programmeret, kan adgang til en dør forblive spærret. For følgeskader, der skyldes spærret adgang, fx til personer, der er sårede eller i fare, tingskader eller andre skader, hæfter SimonsVoss Technologies GmbH ikke!

Blokeret adgang gennem manipulation af produktet

Hvis du selv ændrer produktet, kan der opstå funktionsfejl, og adgang via en dør kan blokeres.

- Modifier kun produktet, når det er nødvendigt, og kun på den måde, der er beskrevet i dokumentationen.

OPMÆRKSOMHED

Beskadigelse på grund af væske

Dette produkt indeholder elektroniske og/eller mekaniske komponenter, som kan blive beskadiget på grund af alle typer væsker.

- Hold væsker væk fra elektronikken.

Beskadigelse på grund af aggressive rengøringsmidler

Produktets overflade kan blive beskadiget på grund af uegnede rengøringsmidler.

- Brug kun rengøringsmidler, der er velegnede til kunststof- og metaloverflader.



BEMÆRK

Korrekt anvendelse

SimonsVoss-produkter er kun beregnet til åbning og lukning af døre og sammenlignelige genstande.

- Anvend ikke SimonsVoss-produkter til andre formål.

Krævede kvalifikationer

Installation og idriftsættelse kræver specialiseret viden.

- Kun uddannet personale må installere og idriftsætte produktet.

Ændringer eller tekniske videreudviklinger kan ikke udelukkes og kan foretages uden forudgående varsel.

Den tyske sprogversion er den originale brugsanvisning. Andre sprog (udkast på kontrakt-sproget) er oversættelser af de originale instruktioner.

Læs og følg alle installations-, installations- og idriftsættelsesinstruktioner. Overfør disse instruktioner og eventuel vedligeholdelsesinstruktion til brugeren.

2 Tilsigtet brug

SREL2.COVER1 er et beskyttelseshus til beskyttelse mod hærværk. Dette giver dig mulighed for at bruge din enhed udendørs og beskytte den mod mekaniske og vejrrelaterede skader.

Følgende enheder er kompatible:









- SREL2 i hvidt designhus (SREL2.*; MK.SREL2.*)
- Ekstern kortlæser til SREL2 (SC.M.E.G2.W(.WP))
- Læser til SREL3 (SREL3.EXT.G2.W(.WP))

3 Leveringsomfang

- 1× hærværksbeskyttelse, bestående af bundplade, ramme og låg
- 2× sikkerhedsskrue med Secutorx-10-drev (formonteret)
- 1× Secutorx-10-skruebit
- 2× A2 unbrakoskrue (DIN 912 M4x8 mm, SW3, formonteret)
- 2× A2 skrue med halvrundet hoved (DIN 7996 5x50 mm, PZ2)
- 2× dyvel (Fischer SX8)

4 Montering

- ✓ Forboring i væggen.
- ✓ SmartRelay åbnes.

- ✓ PZ2-skrueetrækker til rådighed.
 - ✓ SW3-skrueetrækker til rådighed.
 - ✓ Secutorx-10 skrueetrækker til rådighed.
1. Placer den rustfri stålplade mod væggen.

 2. Skru den rustfri stålplade på plads med en PZ2-skrueetrækker. Brug om nødvendigt passende dyvler.

 3. Før kablet gennem SmartRelays bundplade, og tilslut SmartRelay.
 4. Placer SmartRelays bundplade mod den rustfri stålplade.

 5. Skru bundpladen på SmartRelay fast med en SW3-skrueetrækker.

 6. Sæt SmartRelay-dækslet på bundpladen.

 7. Luk låget på SmartRelay.

 8. Placer hærværksbeskyttelsen på den rustfri stålplade.

 9. Tryk låget på hærværksbeskyttelsen mod væggen, og skru låget fast med Secutorx-10-skrueetrækkeren.

- ↳ SmartRelay og hærværksbeskyttelse monteret.



9

5 Tekniske data

Dimensioner (B×H×D)	111,3 mm × 111,3 mm × 30,7 mm
Tæthedsgrad	IP54
Materiale	<ul style="list-style-type: none"> ■ Ramme: ABS (PA6 50% glasfiberforstærket) ■ Bundplade: V2A rustfrit stål
Farve	<ul style="list-style-type: none"> ■ Ramme: Jerngrå, svarende til RAL 7011 ■ Låg: gennemsigtig ■ Bundplade: rustfrit stål



10

6 Hjælp og flere oplysninger

Infomateria- <https://www.simons-voss.com/dk/dokumenter.html>
le/dokumen-
ter

Teknisk sup- +49 (0) 89 / 99 228 333
port

e-mail support-simonsvoss@allegion.com

FAQ <https://faq.simons-voss.com/otrs/public.pl>

SimonsVoss Technologies GmbH, Feringastr. 4, D-85774 Unterföhring,
Tyskland

Innehållsförteckning

1	Allmänna säkerhetsanvisningar	57
2	Avsedd användning.....	59
3	Leveransomfång	59
4	Montering	59
5	Tekniska data.....	61
6	Hjälp och ytterligare information.....	61

1 Allmänna säkerhetsanvisningar

Signalorder
(ANSI
Z535.6)

FARA: Död eller allvarlig personskada (troligt), VARNING: Död eller allvarlig skada (möjligt, men osannolikt), OBSERVERA: Liten skada, OBS: Skador på egendom eller fel, INFO: Låg eller ingen schade



VARNING

Tillgång spärrad

Felaktigt installerade och/eller programmerade komponenter kan leda till att dörrar spärras. SimonsVoss Technologies GmbH ansvarar inte för konsekvenserna av felaktig installation såsom spärrat tillträde till skadade personer eller personer i risksituationer, materiella skador eller andra typer av skador.

Blockerad åtkomst genom manipulering av produkten

Om du ändrar produkten på egen hand kan fel uppstå och åtkomst via en dörr kan blockeras.

- Ändra endast produkten vid behov och endast på det sätt som beskrivs i dokumentationen.

OBS

Skada på grund av vätskor

Den här produkten innehåller elektroniska och/eller mekaniska komponenter som kan skadas av alla typer av vätskor.

- Låt inte elektroniken komma i kontakt med vätskor.

Skada på grund av aggressiva rengöringsmedel

Ytan på den här produkten kan skadas om olämpliga rengöringsmedel används.

- Använd endast rengöringsmedel som lämpar sig för plast- och metallytor.



INFO

Avsedd användning

SimonsVoss-produkter är uteslutande avsedda för öppning och stängning av dörrar och liknande.

- Använd inte SimonsVoss-produkter för andra syften.

Kvalifikationer krävs

Installation och idrifttagning kräver specialiserad kunskap.

- Endast utbildad personal får installera och driftsätta produkten.

Ändringar eller teknisk vidareutveckling kan inte uteslutas och kan komma att genomföras utan föregående meddelande om detta.

Den tyska språkversionen är den ursprungliga bruksanvisningen. Andra språk (utarbetande på kontraktsspråket) är översättningar av originalinstruktionerna.

Läs och följ alla installations-, installations- och driftsinstruktioner. Skicka dessa instruktioner och alla underhållsinstruktioner till användaren.

2 Avsedd användning

SREL2.COVER1 är ett vandalismskyddshölje. Med den kan du även använda enheten utomhus och skydda den mot mekaniska och väderrelaterade skador.

Följande enheter är kompatibla:









- SREL2 i vit designkåpa (SREL2.*; MK.SREL2.*)
- Extern kortläsare för SREL2 (SC.M.E.G2.W(.WP))
- Läsare för SREL3 (SREL3.EXT.G2.W(.WP))

3 Leveransomfång

- 1× vandalismskyddshölje bestående av bottenplatta, ram och lock
- 2× säkerhetskruv med Secutorx-10-drivning (förmonterad)
- 1× Secutorx-10-skrubbit
- 2× A2-sexkantsskruv (DIN 912 M4×8 mm, SW3, förmonterad)
- 2× A2-skruv med halvrunt huvud (DIN 7996 5×50 mm, PZ2)
- 2× Plugg (Fischer SX8)

4 Montering

- ✓ Vägg förborrad.
- ✓ Smartrelä öppet.

- ✓ PZ2-skruvmejsel finns.
 - ✓ SW3-skruvmejsel finns.
 - ✓ Secutorx-10-skruvmejsel finns.
1. Placera plattan av rostfritt stål mot väggen.
 1
 2. Skruva fast plattan av rostfritt stål med en PZ2-skruvmejsel. Använd vid behov lämplig plugg.
 2
 3. För kabeln genom Smartrelä-bottenplattan och anslut Smartrelä-enheten.
 4. Placera Smartrelä-bottenplattan mot plattan av rostfritt stål.
 3
 5. Skruva fast Smartrelä-bottenplattan med en SW3-skruvmejsel.
 4
 6. Placera Smartrelä-locket på bottenplattan.
 5
 7. Stäng Smartrelä-locket.
 6
 8. Placera locket till vandalismskyddshöljet på plattan av rostfritt stål.
 7
 9. Tryck vandalismskyddshöljets lock mot väggen och skruva fast det med Secutorx-10-skruvmejseln.
 8

↳ Smartrelä och vandalismskyddshölje monterade.



9

5 Tekniska data

Mått (B × H × D)	111,3 mm × 111,3 mm × 30,7 mm
Kapslingsklass	IP54
Material	<ul style="list-style-type: none"> ■ Ram: ABS (PA6 50 % glasfiberförstärkt) ■ Bottenplatta: V2A rostfritt stål
Färg	<ul style="list-style-type: none"> ■ Ram: Järngrå, liknande RAL 7011 ■ Lock: Transparent ■ Bottenplatta: Rostfritt stål



10

6 Hjälp och ytterligare information

Infomaterial/
dokument <https://www.simons-voss.com/se/dokument.html>

Teknisk
support +49 (0) 89 / 99 228 333
support-simonsvoss@allegion.com

FAQ <https://faq.simons-voss.com/otrs/public.pl>

SimonsVoss Technologies GmbH, Feringastr. 4, D-85774 Unterföhring,
Tyskland



This is SimonsVoss

SimonsVoss, the pioneer in remote-controlled, cable-free locking technology provides system solutions with a wide range of products for SOHOs, SMEs, major companies and public institutions. SimonsVoss locking systems combine intelligent functionality, high quality and award-winning design Made in Germany.

As an innovative system provider, SimonsVoss focuses on scalable systems, high security, reliable components, powerful software and simple operation. As such, SimonsVoss is regarded as a technology leader in digital locking systems. Our commercial success lies in the courage to innovate, sustainable thinking and action, and heartfelt appreciation of employees and partners.

SimonsVoss is a company in the ALLEGION Group, a globally active network in the security sector. Allegion is represented in around 130 countries worldwide (www.allegion.com).

Made in Germany

SimonsVoss is truly committed to Germany as a manufacturing location: all products are developed and produced exclusively in Germany.

© 2023, SimonsVoss Technologies GmbH, Unterföhring

All rights are reserved. Text, images and diagrams are protected under copyright law.

The content of this document must not be copied, distributed or modified. You can find more information on our website. Subject to technical changes.

SimonsVoss and MobileKey are registered brands belonging to SimonsVoss.

SimonsVoss
technologies

Made in Germany

A BRAND OF

