

30
60

 VOSS

Locking cylinder (Z4) 3061

Manual

15.10.2024

Simons  Voss
technologies

Contents

1.	Intended use.....	5
2.	General safety instructions	6
3.	Product specific safety notices.....	9
4.	General.....	12
4.1	Product description.....	12
4.2	Locking cylinder design.....	13
4.3	Half cylinder design	14
4.4	Opening and locking from the outside.....	14
4.5	Opening and locking from the inner side	15
5.	Versions	16
5.1	FD version (Standard)	17
5.2	HZ version (Standard).....	17
5.3	Half-cylinder (HZ) version (self-locking)	17
5.4	ZK version.....	19
5.5	version for steel and fire retardant doors	19
5.6	TS version.....	20
5.7	MR option.....	20
5.8	MS version.....	21
5.9	SKG or VdS versions (SZ)	21
5.10	AP version.....	22
5.11	AP2 Version	23
5.12	CO version.....	24
5.13	WP Version (FD).....	24
5.14	WP version (HZ/CO/AP)	24
5.15	SW version (CO).....	24
5.16	VR version (HZ)	24
5.17	DK version (HZ)	24
5.18	DM version.....	25
5.19	Hybrid-Version	25
5.20	Extra lengths.....	25
5.21	Examples of locking cylinder use.....	25
6.	Installation instructions.....	27
6.1	General instructions	27

6.2	Programming the locking cylinder	27
6.3	Installation variants.....	27
6.3.1	Installation.....	27
6.3.2	Fitting an anti-panic cylinder.....	31
6.3.3	Installation of SKG/VdS cylinders.....	34
6.3.4	Half Cylinder DK/MR.....	35
6.3.5	Installing Swiss Round.....	43
6.3.6	Magnetic plate for DoorMonitoring.....	43
6.4	Core extraction protection adapter.....	43
6.4.1	Installation Z4.KA & Z4.KA.SET	43
6.4.2	Installation Z4.MP.KA.SET	45
6.5	Installing a LockNode	45
6.5.1	Installing a LockNode.....	46
6.5.2	Installing a LockNode MP	47
7.	Audible signals	51
7.1	Battery warnings.....	52
7.2	Battery warning for transponders	54
8.	System 3060 battery replacement.....	55
8.1	General instructions	55
8.2	Battery life.....	55
8.3	Emergency battery procedure	56
8.3.1	Storage mode (G1).....	56
8.3.2	Freeze mode (G2).....	56
8.4	Procedure.....	57
8.5	Procedure for outer thumb turn (MH cylinder).....	58
9.	Maintenance, cleaning and disinfection	60
10.	Areas of use.....	61
10.1	General	61
10.2	Fire doors.....	61
10.3	Doors along rescue routes	61
10.4	Installation outdoors.....	61
11.	Accessories.....	62
11.1	Thumb-turns	62
11.2	Core extraction protection adapter (Z4.KA.SET)	62
11.3	Core extraction protection extension for SKG/VdS cylinders (Z4.KA.SET2).....	62
11.4	Core extraction protection extension for SKG/VdS cylinders (Z4.KA.SET2.IT).....	62
11.5	Tool	63

11.6	Battery set.....	63
12.	Technical data.....	64
12.1	Locking cylinder.....	64
12.2	Half cylinder.....	66
12.3	Dimensional drawings cylinder.....	67
13.	Declaration of conformity.....	76
14.	Help and other information.....	77

1. Intended use

Digital SimonsVoss Locking Cylinder 3061 are installed in designated door locks, such as DIN mortise locks, to integrate them into a digital locking system.

The digital Locking Cylinder 3061 may only be used for its intended purpose in a designated door locking device. No other use is permitted.

Digital Locking Cylinder 3061s are available in various lengths. The selection of the proper size is of significance. The length of the locking cylinder is printed on the packaging and can be measured at any time. If the cylinder is too short, the handles cannot be fitted. If the cylinder is too long, it may be ripped out of the locking device. The may not protrude more than 3 mm on each side of the door to ensure proper operation.

The product may not be changed in any way, other than in compliance with the changes described in the instructions.

2. General safety instructions

Signal word: Possible immediate effects of non-compliance

DANGER: Death or serious injury (likely)

WARNING: Death or serious injury (possible, but unlikely)

CAUTION: Minor injury

IMPORTANT: Property damage or malfunction

NOTE: Low or none



WARNING

Blocked access

Access through a door may stay blocked due to incorrectly fitted and/or incorrectly programmed components. SimonsVoss Technologies GmbH is not liable for the consequences of blocked access such as access to injured or endangered persons, material damage or other damage!

Blocked access through manipulation of the product

If you change the product on your own, malfunctions can occur and access through a door can be blocked.

- ❑ Modify the product only when needed and only in the manner described in the documentation.

Do not swallow battery. Danger of burns from hazardous substances

This product contains lithium button cell batteries. Swallowing the button cell battery, in can result in severe internal burns leading to death in as little as two hours.

1. Keep new and used batteries away from children.
2. If the battery compartment does not close securely, cease using the product and keep it away from children.
3. If you think batteries have been swallowed or are in any part of the body, seek medical attention immediately.

Risk of explosion due to incorrect battery type

Inserting the wrong type of battery can cause an explosion.

- ❑ Only use the batteries specified in the technical data.



CAUTION

Fire hazard posed by batteries

The batteries used may pose a fire or burn hazard if handled incorrectly.

1. Do not try to charge, open, heat or burn the batteries.
2. Do not short-circuit the batteries.

IMPORTANT

Damage resulting from electrostatic discharge (ESD) when enclosure is open

This product contains electronic components that may be damaged by electrostatic discharges.

1. Use ESD-compliant working materials (e.g. Grounding strap).
2. Ground yourself before carrying out any work that could bring you into contact with the electronics. For this purpose, touch earthed metallic surfaces (e.g. door frames, water pipes or heating valves).

Damage resulting from liquids

This product contains electronic and/or mechanic components that may be damaged by liquids of any kind.

- ❑ Keep liquids away from the electronics.

Damage resulting from aggressive cleaning agents

The surface of this product may be damaged as a result of the use of unsuitable cleaning agents.

- ❑ Only use cleaning agents that are suitable for plastic or metal surfaces.

Damage as a result of mechanical impact

This product contains electronic components that may be damaged by mechanical impacts of any kind.

1. Avoid touching the electronics.
2. Avoid other mechanical influences on the electronics.

Damage due to polarity reversal

This product contains electronic components that may be damaged by reverse polarity of the power source.

- ❑ Do not reverse the polarity of the voltage source (batteries or mains adapters).

Operational malfunction due to radio interference

This product may be affected by electromagnetic or magnetic interference.

- ❑ Do not mount or place the product directly next to devices that could cause electromagnetic or magnetic interference (switching power supplies!).

Communication interference due to metallic surfaces

This product communicates wirelessly. Metallic surfaces can greatly reduce the range of the product.

- ❑ Do not mount or place the product on or near metallic surfaces.
-



NOTE

Intended use

SimonsVoss-products are designed exclusively for opening and closing doors and similar objects.

- ❑ Do not use SimonsVoss products for any other purposes.

Malfunctions due to poor contact or different discharge

Contact surfaces that are too small/contaminated or different discharged batteries can lead to malfunctions.

1. Only use batteries that are approved by SimonsVoss.
2. Do not touch the contacts of the new batteries with your hands.
3. Use clean and grease-free gloves.
4. Always replace all batteries at the same time.

Different times for G2 locks

The internal time unit of the G2 locks has a technical tolerance of up to ± 15 minutes per year.

- ❑ Regularly reprogram time-critical locking devices.

Qualifications required

The installation and commissioning requires specialized knowledge.

- ❑ Only trained personnel may install and commission the product.

Incorrect installation

SimonsVoss Technologies GmbH accepts no liability for damage caused to doors or components due to incorrect fitting or installation.

Modifications or further technical developments cannot be excluded and may be implemented without notice.

The German language version is the original instruction manual. Other languages (drafting in the contract language) are translations of the original instructions.

Read and follow all installation, installation, and commissioning instructions. Pass these instructions and any maintenance instructions to the user.

3. Product specific safety notices



WARNING

Escape door function malfunction

The use of unsuitable components or ones that are not ready for operation can impair the function of an escape door. If you use the anti-panic cylinder in non-approved locks, the escape door function may be impaired and cannot be released again.

1. Make sure that all parts of the lock are ready for operation.
2. Make sure that the panic function of the mortise lock is ensured.
3. Please refer to the documentation of the lock manufacturer.
4. Use the anti-panic cylinder within the specified temperature range.
5. Perform a function test after installing the anti-panic cylinder or changing its battery.



CAUTION

Use of the anti-panic version of the locking cylinder in non-approved locks

If you use the anti-panic version of the locking cylinder in unauthorised locks, the escape door function may be impaired and cannot be released again.

1. Only use the anti-panic version of the locking cylinder in locks for which the locking cylinder is expressly approved.
2. Please refer to the documentation of the respective lock manufacturer.
3. Contact SimonsVoss Technologies GmbH for further information on this subject (see *Help and other information* [▶ 77]).

Hand injuries from carrier springing back

A spring-loaded carrier is used in the anti-panic construction of the closing cylinder. This carrier can spring back when it is not installed, causing hand injuries.

- Do not hold the anti-panic construction of the closing cylinders in the area of the carrier.

IMPORTANT

Damage caused by moisture in outdoor use

Moisture can damage the electronics.

1. If you want to use the locking cylinder for outdoor applications or in high humidity (bathrooms or washrooms), use the WP version.
2. Carefully insert the locking cylinder to avoid damaging the O-rings.

Mechanical damage to the thumb turn as a result of obstacles

If the thumb turn can knock against the wall or other objects as a result of the installation situation, it may become damaged.

- In such situations, use a suitable door stop.

Mechanical damage to the thumb turn through misuse as door-opener

Some doors are very heavy and solidly constructed. The thumb turn is not suitable for opening such doors.

1. Don't pull the thumb turn to open doors.
2. Make suitable door openers available (suitable handles) to avoid misuse of the thumb turn.

DoorMonitoring in gear locks

Door monitoring cylinders are not suitable for operation in multi-lock systems with gear (gear locking devices). Except: DM.AP2, without bolt monitoring.

- Do not use door monitoring cylinders in gear locking devices.



NOTE

Maintenance interval of not more than one month for emergency exit locks

As per European standard EN 179, Appendix C, all components in a locking device must be checked at intervals no greater than one month to ensure that they are in satisfactory working order as part of emergency exit locking device maintenance.

Locking up of persons without means of identification

The freely-rotating construction of the closing cylinder can only be opened with a means of identification from both sides.

- Ensure that no persons without means of identification are in the secured area.

Length of locking system password

For security reasons, the locking system password must consist of at least 8 characters. The code length for digital closing cylinders (*and for System 3060/3061 and MobileKey*) corresponds to 2¹⁶⁸ Bit.

Fault in the interior knob due to moisture

The inner knob of the closing cylinder is of protection class IP40 and is thus not protected from moisture.

- Ensure that the interior knob cannot come into contact with water.

Battery changes may only be carried out by trained personnel and only with the intended battery key (Z4.SCHLUESSEL)!

Programming with obsolete LSM version

New components can only be programmed with the current version of LSM.

Difficulty of operation of the lock due to stiff latch or bolt

If the latch or bolt of the mortice lock are stiff, the closing cylinder will also be stiff.

- ❑ Check that the latch or the bolt of the mortice lock are free-moving.

Fitting error or incorrect order

If you make a mistake in measuring the door and order a closing cylinder, the closing cylinder will not fit.

- ❑ Check the dimensions of the door again before ordering.
-

4. General

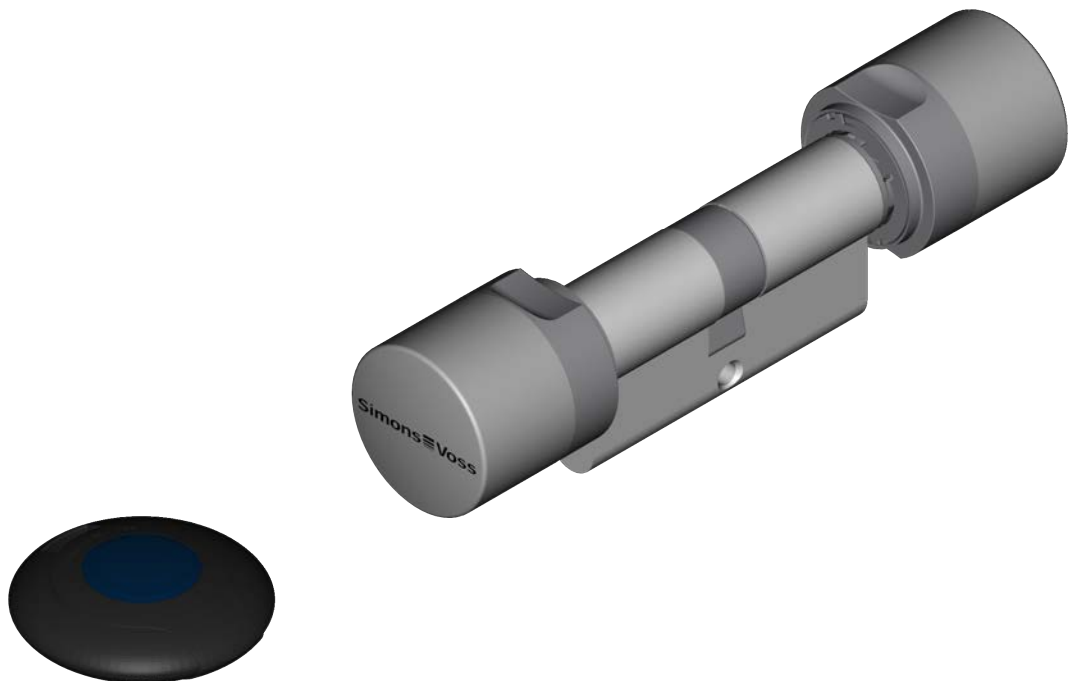

4.1 Product description

The SimonsVoss Digital Locking System 3060 is an electronic version of a mechanical locking system with the functions of a typical access control system.

Digital Locking Cylinder 3061 and the digital half cylinder are a main component in the locking and access control system, where radio communication replaces the mechanical authentication of a conventional key.

This product description details both the locking cylinder and the half cylinder. The design and operating mode of the two products are comparable in many respects. Any differences between the two products and different versions are pointed out in the corresponding sections.

'Locking cylinder' is taken to mean both 'locking cylinder' and 'half cylinder' in this document unless explicitly stated otherwise or taken out of context.

Data are transmitted for authentication using a transponder (25kHz inductive) or a smart card featuring the RFID standard MIFARE[®] Classic or MIFARE[®] DESFire.

Refer to the respective manuals for details about smart card products (SC). This description mentions the smart card cylinder, but does not describe it in any detail.

The locking cylinder is supplied in different versions and meets different profile standards, such as DIN 18252/EN1303, so that almost any lock anywhere in the world can be retrofitted with this cylinder. Digital Locking

Cylinder 3061 has much to offer – greater security, greater flexibility, lower costs, network-ready without any wiring on the door or frame and less time and effort required for installation.

Digital Locking Cylinder 3061 is powered by two batteries in a redundant system. Cylinders operate as stand-alone components thanks to this integrated power supply, which also means there is no need to wire doors. An intelligent battery warning system also increases reliability.

The SimonsVoss system elements are not configured before delivery from the factory. They are first assigned to a locking system during initial programming. This makes it easier for stock keeping and makes product management simpler.

Thanks to modularity, all locking cylinders are seamlessly integrated into the SimonsVoss System 3060 and, like all SimonsVoss components, they can be programmed using the locking plan software. Other authentication components, such as Pin Code Keypad 3068, Biometric Reader Q3008 or Compact Reader 3078, can be connected as a wireless element. If the system is extended at a later stage, cylinders can be networked without wiring and managed in an online interconnected system.

The locking cylinders are provided with two different firmware generations – G1 and G2. G2 features a more efficient communication protocol than G1. It will allow you to create larger, more efficient locking systems.

Authorisations are written both on the locking cylinder and the transponder, thus delivering greater flexibility for programming. A G2 system can also form a virtual network, i.e. authorisations and blocking lists are written on the transponder and transmitted into the locking system. Refer to the G2 manual for more details.

4.2 Locking cylinder design

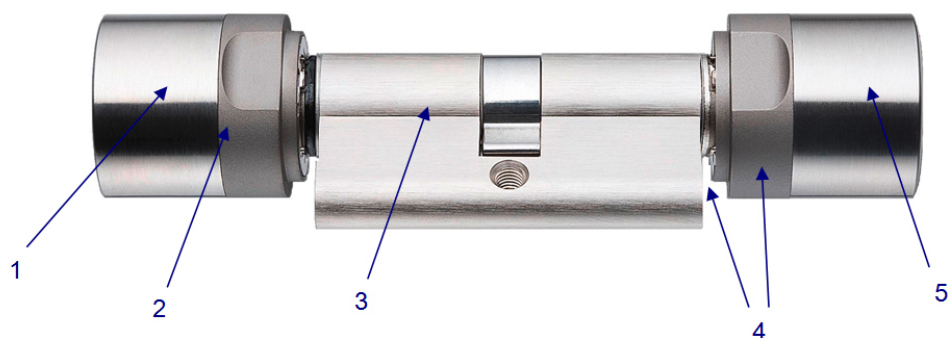

1. Inside thumb-turn
2. Batteries/electronics
3. Actuator

4. Drilling protection
5. Outer thumb-turn

4.3 Half cylinder design

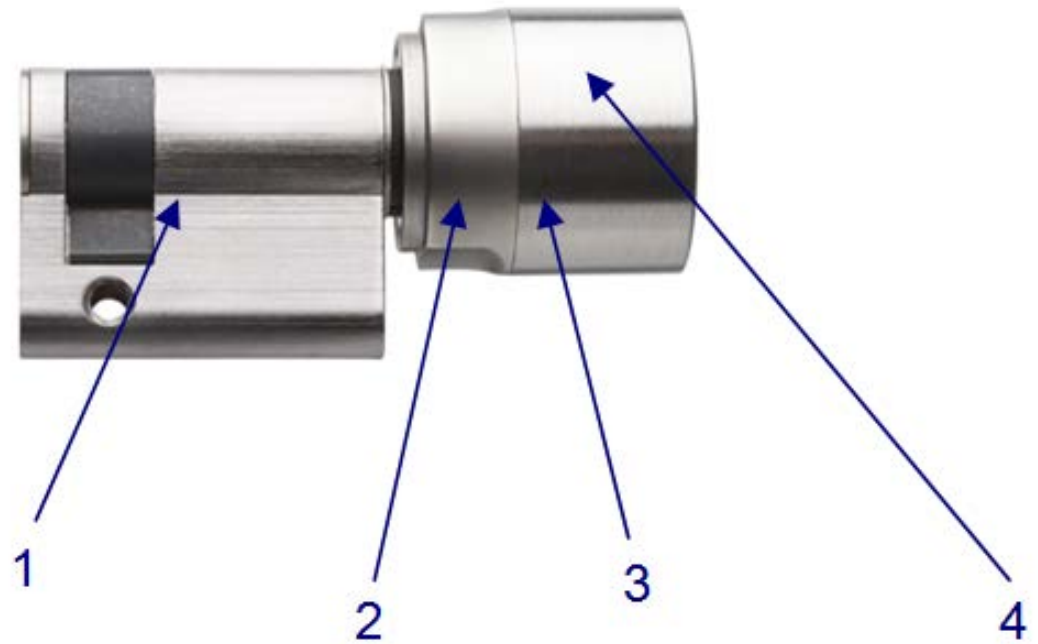

1. Actuator
2. Electronics
3. Batteries
4. Thumb-turn

4.4 Opening and locking from the outside

With freely rotating locking cylinders (FD)

The outer and inside thumb-turn rotate freely when not activated in the freely rotating Locking Cylinder 3061, meaning it is not possible to open or lock the door without a valid ID medium. Identify yourself with your valid ID medium on the outer thumb-turn to activate the cylinder. If the ID medium is authorised, an audible signal will sound twice, the blue LED will flash twice and the locking cylinder will engage ready to open. Turn the outer thumb-turn in the direction of locking or opening. You have about five seconds to do so. The engage time can be configured. A single audible signal will then sound and the outer or inside thumb-turn will rotate freely again. Ensure that the outside or inside locking cylinder thumb-turn rotates freely again after the thumb-turn has been engaged ready for use.

**NOTE**

If the user has an ID medium which is not authorised for use at that particular moment due to the time zone plan, a single audible signal will sound. The cylinder will not engage, so the outer or inside thumb-turn continues to rotate freely and the user cannot open the door. You need to configure this response separately in third-party systems.

4.5 Opening and locking from the inner side

With freely rotating locking cylinders (FD)

The outer and inside thumb-turn rotate freely when not activated in the freely rotating Locking Cylinder 3061, Doors can also only be opened or locked on the outside using an ID medium on the inside thumb-turn.

With non-freely rotating locking cylinders (CO)

Locking Cylinder 3061s which are permanently engaged for use can be operated from the inside without a ID medium. In this case, the door can be opened and closed using the inside thumb-turn without an authorised ID medium.

5. Versions

Different versions of the digital Locking Cylinder 3061 are offered to cover the different needs of the market. The different versions are indicated by a code. The different versions can be combined:

ABBREVIATION	DESIGNATION	LOCKING CYLINDER	HALF CYLINDER
FD	Standard (freely rotating)	X	
HZ	Half cylinder		X
Access control	Access Control	X	X
FH	Fire-retardant version	X	
TS	Button control	X	
MR	Multi-point	X	X
MS	Brass version	X	X
SKG	Class AZ VdS cylinder (basic protection against picking)	X	
VDS	Class BZ VdS cylinder (medium protection against picking)	X	
AP	Anti-panic function	X	
CO	Comfort cylinder	X	
WP	Waterproof - WP	X	X
SW	Seawater-proof	X	
WN	Network integrated	X	X
SC	SmartCard version	X	
VR	Shortened range		X
DK	Detachable knob		X
DM	Door Monitoring	X	

Refer to the current product catalogue to see which particular versions can be combined with one another. Locking cylinders are also supplied in different profiles to satisfy differences in different regions:

PROFILE	LOCKING CYLINDER	HALF CYLINDER
Standard Euro profile cylinder as per DIN 18252/EN1303	X	X
Scandinavian Oval		X
British oval	X	
Swiss Round	X	X

Locking Cylinder 3061s are also offered in mortise and rim cylinder models for American door profiles.

5.1 FD version (Standard)

Locking Cylinder 3061 freely rotating on both sides.

The .FD double thumb-turn cylinder is available from a length of 30-30 mm.

5.2 HZ version (Standard)

The standard version of the half cylinder.



5.3 Half-cylinder (HZ) version (self-locking)



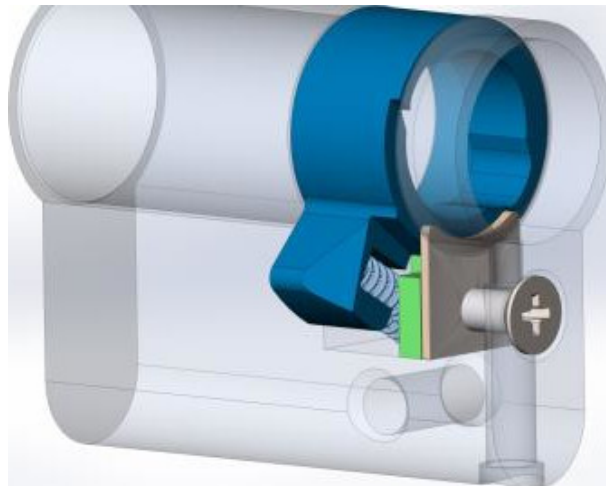

Variant of the half cylinder with self-locking by means of a spring-loaded catch with a fixed reset position. Due to the spring and the bevelled edge on the cam, locking is possible without an identification medium by pressing in (.SL). The main application is, for example, installation in swivel lever handles for switch and distribution cabinets or server racks in data centres.



The technical data differs slightly from the normal half cylinder:

Angle driver position	37°
Driver width from zero position	11 mm

If the self-locking mechanism is used frequently, it is advisable to apply a little grease to the engagement edge on the switch cabinet lever handle.

All known options for the half cylinder are possible with the following exceptions:

- .MR
- .MS

- .DK

- .WP

The usual lengths of half cylinders for lever handles are 30-10 mm and 35-10 mm.



5.4 ZK version

Design is similar to standard version but with access logging and time zone control.

- Access event logging

The locking cylinder logs up to 3,072 of the most recent access events with the date, time and transponder ID (TID). The data can be read via the network using the programming device.

- Time zone control

The Locking Cylinder 3061 can be programmed in such a way that authorized transponders are only authorized for access at specific times. For G1, there are 5 (+1) time zone groups available per area (e.g. outer perimeter) within the different time zone schedules while G2 has 100 (+1) such groups.

5.5 version for steel and fire retardant doors

Design is similar to standard version but for doors with sturdy metal sections, such as fire doors, or doors with highly protective shielding. This version is recommended in areas with high interference fields, such as server rooms, and for all metal doors. The FH version cannot be retrofitted.

If wired networks are used, we recommend using this cylinder version due to its reduced projection.

Before a locking cylinder is installed into a fire/smoke retardant door, the fire certification has to be checked first to ensure that conformity is in place.

It must be ensured that any locking devices or sealing strips do not impede the orderly operation of the MC.

5.6 TS version

Design as for standard version, but with the additional option of allowing the cylinder to engage without an identification medium. This cylinder version can be engaged mechanically with the aid of two buttons on the inside thumb-turn. This means that no transponder is needed when the user is on the internal. The cylinder will then engage for five seconds (configurable) and the door can be opened or locked. Once this time interval expires, the cylinder rotates freely again on both sides.

The .TS version cannot be retrofit.



NOTE

Retrofitting of network caps (LNI) for knobs with button control (.TS) not recommended

The push-button makes it difficult to fit a network cap and the product may be damaged.

- SimonsVoss advises against retrofitting .TS cylinders with a network cap.

5.7 MR option

Design is similar to standard version but the locking cam features fixed points where it positions itself when disengaged. This version is particularly suitable for very smooth-running locks with multi-point locking systems.

Please observe the lock manufacturer's declaration of conformity when combining multi-point locks with a panic function.

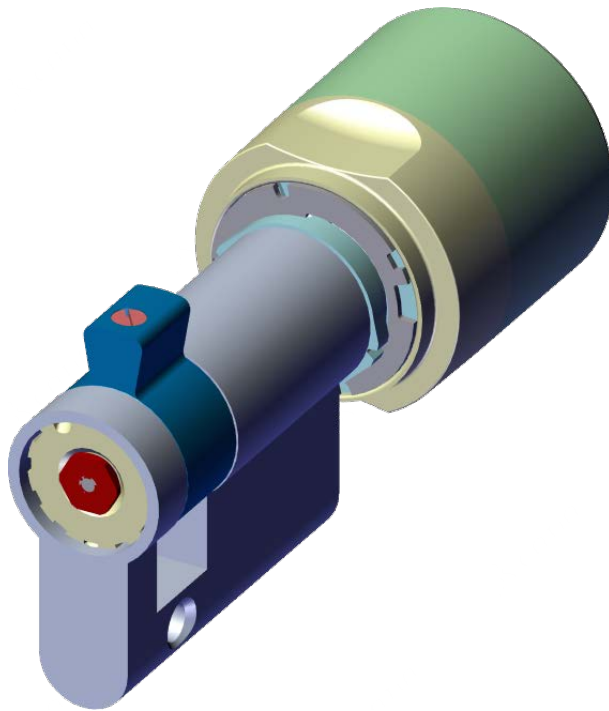

5.8 MS version

The Locking Cylinder 3061 can be supplied with stainless steel or brass colour finish (highly glossy thumb-turn covers).



5.9 SKG or VdS versions (SZ)

The Locking Cylinder 3061 is optionally also available as a VdS cylinder. The additional mechanical security features ensure that VdS Classes AZ and BZ or Class SKG*** are achieved. These versions cannot be combined with the brass and WP versions. The VdS cylinder can only be supplied in combination with access control (ZK) functions.



NOTE

The profile cylinder must be protected with a VdS-approved burglar-resistant class B or C door label. Such door plates conform to DIN 18257, Class ES 2 or ES 3. The cylinder may not protrude more than 3 mm above the door plate. The scope of burglary-resistant measures is based on the respective national provisions.

This version is available as .MS, .FH and WN versions.

5.10 AP version

A cylinder with an anti-panic function must be fitted to all doors where the lock's panic function may be adversely affected by the position of the cam. This version contains an integrated spring mechanism which places the locking cam in a non-critical position, meaning a panic lock's panic function cannot be blocked.

In contrast to all other cylinders, the .AP type cylinder is fitted the other way round with the thumb-turn containing the battery and the electronics module installed on the outside (see diagram).

Unlike the standard anti-panic cylinder (AP), the inside thumb-turn of which is permanently engaged, the inside thumb-turn for the freely-rotating AP version (AP.FD) is disengaged mechanically and cannot be engaged with an identification medium.

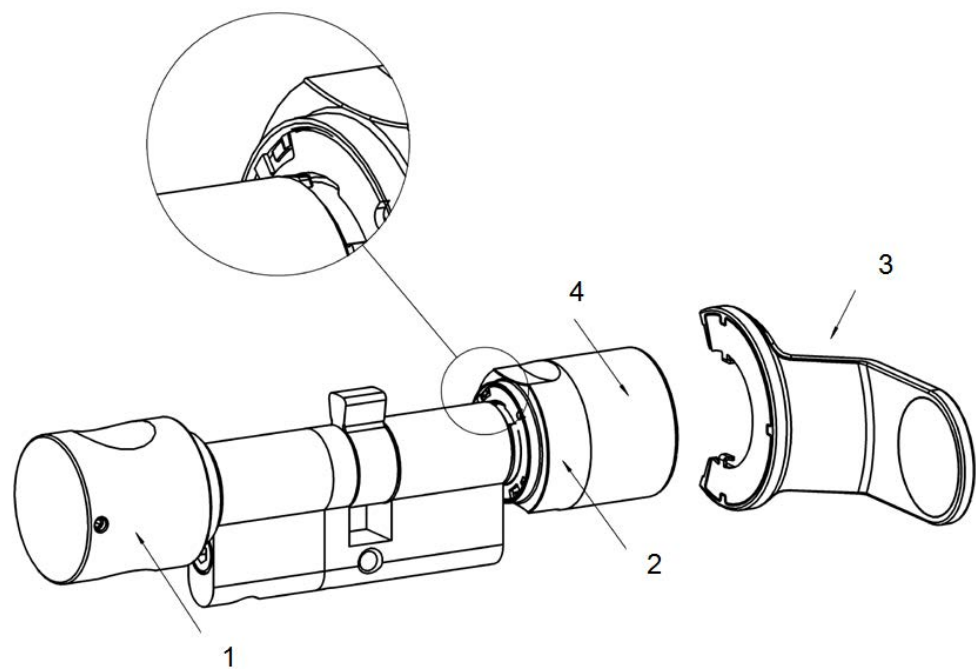

1. Inside thumb-turn
2. Recessed grip ring
3. Battery replacement key
4. Outside thumb-turn

The following aspects should be taken into consideration for doors along rescue routes which have been installed after April 1, 2003 (exit devices as per DIN EN 179 or DIN EN 1125): All Locking Cylinder 3061 models may be used for all exit devices where their approval states that the Locking Cylinder 3061 has no impact on the lock's function. The Locking Cylinder

3061 type .AP (anti-panic cylinder) must be used for all exit devices where the Locking Cylinder 3061 cam position affects the lock's function. This must be stated in the lock manufacturer's approval.



DANGER

Due to the structural design of panic locks, it is not permitted to turn the Locking Cylinder 3061 thumb-turn to the stop position when the door is locked since this may affect the lock's panic function.

5.11 AP2 Version

A cylinder with an anti-panic function must be fitted to all doors where the locking device's panic function may be adversely affected by the position of the cam. This version contains an integrated spring mechanism which places the locking cam in a non-critical position, meaning a panic locking device's panic function cannot be blocked.

Installation is the same as with the regular Locking Cylinder 3061.

The following aspects should be taken into consideration for doors along rescue routes which have been installed after April 1, 2003 (exit devices as per DIN EN 179 or DIN EN 1125): All Locking Cylinder 3061s may be used with all closures whose approval states that the Locking Cylinder 3061 has no effect on the function of the lock. The Locking Cylinder 3061 type AP2 (anti-panic cylinder) must be used where necessary for all locks in which the position of the Locking Cylinder 3061 cam has an effect on the function of the lock; this must be specified in the approval of the lock manufacturer.



DANGER

Due to the structural design of panic locks, it is not permitted to turn the thumb-turn of the Locking Cylinder 3061 to the stop position when the door is locked since this may affect the lock's panic function.

IMPORTANT

Loss of magnetisation and authorisation of the cylinder

The magnetisation can be lost on an AP2 cylinder. On affected cylinders, the identification medium must be actuated again.

Possible causes: Flip-flop mode, time changeover, sluggish locks or the operation of deadbolt switches with resistance on the AP2 cylinder driver.

1. Do not use flip-flop mode and time switching for AP2 cylinders.
2. Do not use the AP2 cylinder for locks that are difficult to operate or for deadbolt switches with resistance on the follower.

5.12 CO version

In the comfort cylinder (CO), the inside knob is permanently interconnected with the locking cam, so that doors can be opened and locked from the inside without needing to use a transponder.

5.13 WP Version (FD)

The protection rating is increased from IP54 to IP66 in the WP version (weatherproof) of the Locking Cylinder 3061. This version is thus suitable for use outdoors or on external doors even if the cylinder is not exposed to direct splash water.

Anti-panic cylinder: The WP version is specifically designed for outdoor areas and should be fitted if the outer thumb-turn comes into contact with water (e.g. rainwater). The WP version features greater resistance to water, meaning the cam should not come into contact with water.

This version is available from a length of 30-35 mm and as .FD, .ZK, .MS and .FH models.

5.14 WP version (HZ/CO/AP)

The electronic thumb-turn is sealed in the WP version of the half, comfort and anti-panic cylinders, thus providing an increased protection rating of IP66. This version is thus suitable when the electronics side is outdoors, i.e. the electronic thumb-turn is exposed to rain, for example. Water must not enter through the door.

5.15 SW version (CO)

The SW (seawater) version of the comfort cylinder has been specially developed for use on ships or for direct use on the sea. A V4A knob and a coated handle component are used on the outside.

5.16 VR version (HZ)

This version features a shortened operating range. It is suitable for use in items such as locker doors and mail box systems when the distance to the next door is less than 40 cm.

5.17 DK version (HZ)

The knob can be detached and is ideal for installation behind cover plates on key switches, for example.

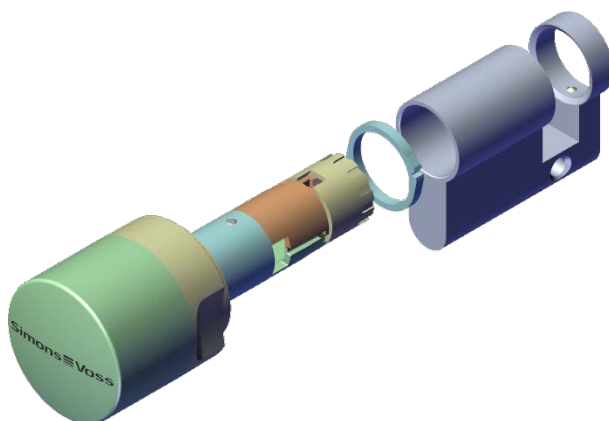

5.18 DM version

The DoorMonitoring cylinder allows the Locking Cylinder 3061 to transmit door events to LSM in real time.



NOTE

DM cylinders cannot be used in multi-lock systems with gears (gear locks).



5.19 Hybrid-Version

With the hybrid version of the digital locking cylinder, active identification media (e.g., transponders) and passive identification media (e.g., MIFARE or DESFire cards) can be used.

5.20 Extra lengths

All double knob cylinders are available with an overall length of up to 140 mm or a maximum of 90 mm on one side. Longer lengths can be supplied on request. All half cylinders are available with an overall length of up to 100 mm or a maximum of 90 mm on the outside. Longer lengths can be supplied on request.

5.21 Examples of locking cylinder use

FD (ZK)	FH (ZK)	TS (ZK)	AP (ZK)
---------	---------	---------	---------

Entrance doors	Fire doors	Apartment entrance doors	Anti-panic doors*
Apartment entrance doors	Aluminium doors	Office doors	Emergency exits*
Office doors			
Connecting doors			
Self-locking doors			

*Comply with EN 179 and EN 1125 requirements and the lock manufacturer's data sheets.

The different versions can be combined as you wish. Exceptions are indicated in the individual model descriptions.

6. Installation instructions

6.1 General instructions

When installing the digital Locking Cylinder 3061, ensure that there are no sources of low-frequency radio interference in the surrounding area.

The profile cylinder housing should be fitted flush in outside areas; it should project a maximum of 3 mm and a profile cylinder escutcheon or security fitting should be installed if necessary. It is also important to ensure that no water is able to penetrate the cylinder via the cam section.

You must not strike the thumb-turns when installing the cylinder.

All thumb-turns are locked into place with a bayonet mount (exception: anti-panic inside knob and SKG/VdS outside knob).

The inner side of the Locking Cylinder 3061 is laser-engraved with (the letters IL for inside length) on the profile cylinder housing; the electronics side is identifiable by the black plastic ring between the thumb-turn and the profile cylinder housing.

Batteries are already installed before delivery.

All the tasks listed in this section can also be carried out using the installation/battery key.

6.2 Programming the locking cylinder

Both the digital Locking Cylinder 3061 and the associated transponder must be programmed before installation. You can find more detailed information in the software operation instructions.

6.3 Installation variants

6.3.1 Installation

The inner side is marked on the cylinder body.

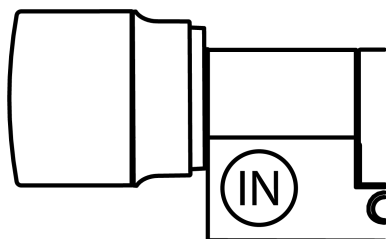

- ✓ PH2 SCREWDRIVER (or Z4.DM.SCREWDRIVER for DoorMonitoring variants)
- ✓ Installation or battery key
- ✓ Cylinder programmed.

1. Remove the thumb-turn (CO: inside, FD: outside).

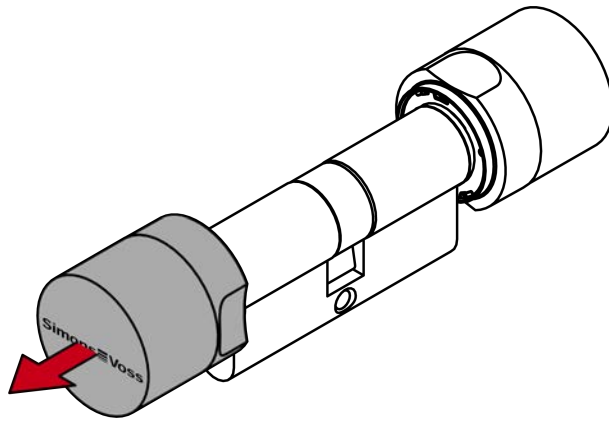

2. Insert the cylinder into the door (CO: from outside; FD: from inside).

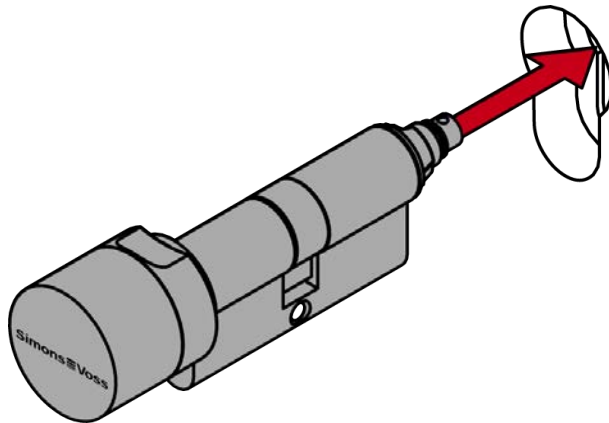

3. Affix the cylinder with the fastening screw (3.5 Nm).

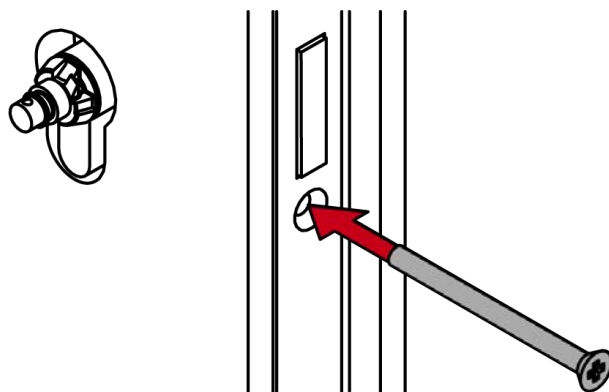

4. Replace the thumb-turn.

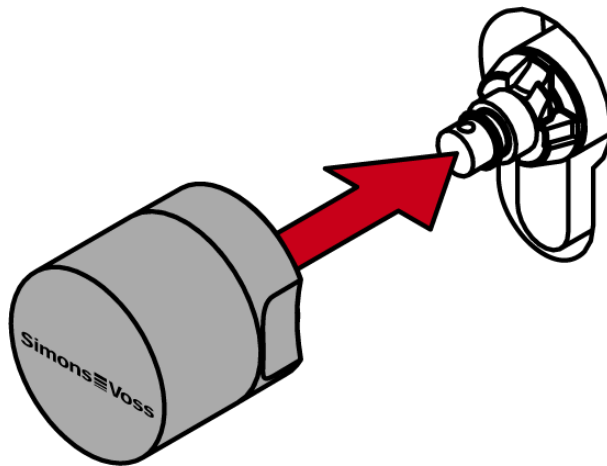

5. Turn the thumb-turn anticlockwise until it locks into the indents in the flange.
To do so, turn the locking disc back using the installation key if necessary.
6. Place the installation key on the thumb-turn from the rear so that it lies flat.

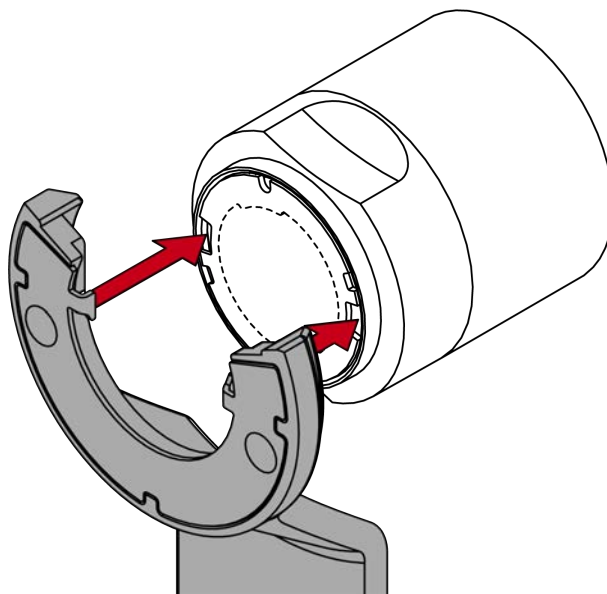

7. Turn the thumb turn until the installation key teeth engage into the locking disc.

8. Hold the thumb turn firmly and carefully turn the installation key about 30° counter-clockwise.

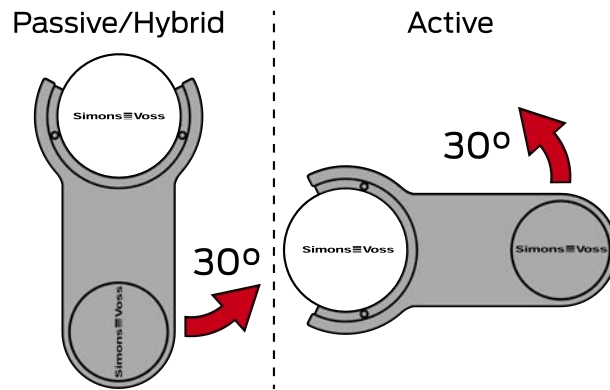

↳ The locking disc will click.

9. VdS/SKG variants only: Screw the hex screw into the thumb-turn tightly.

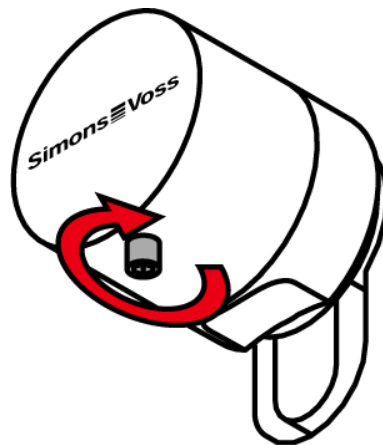

↳ Cylinder fully installed.

DM variants

1. Clean the door frame around the strike plate.
2. Stick the magnetic tab onto the door frame in such a way that the fastening screw is exactly above it when the door is closed.

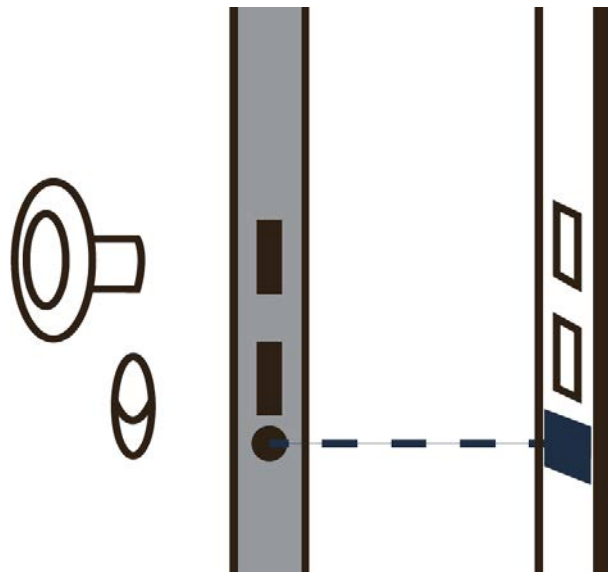

6.3.2 Fitting an anti-panic cylinder

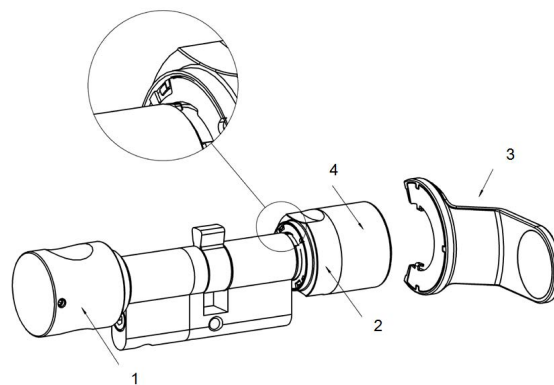

1. Inside thumb-turn
2. Recessed grip ring
3. Battery replacement key
4. Outside thumb-turn

The locking cam is always in a pre-defined position in the AP cylinder when disengaged. This prevents accidental blocking. Unlike other cylinder versions, the AP cylinder is installed the other way round (inserted into the lock from the inside to the outside).

IMPORTANT

Damage resulting from liquids

This product contains electronic and/or mechanic components that may be damaged by liquids of any kind.

- Keep liquids away from the electronics.

Violent action on the thumb turn

Don't strike the thumb turns when installing the cylinder.

6.3.2.1 Removing the inside thumb-turn

Loosen the inside thumb-turn's threaded pin (see diagram above) using an Allen key (1.5 mm). Do not unscrew completely. Hold the cam firmly and then turn the inside thumb-turn anti-clockwise or, in the case of a freely rotating AP cylinder, remove the thumb-turn after loosening the threaded pin.

6.3.2.2 Fastening the digital cylinder into the locking device

Turn the cam until it is vertical and pointing downwards. Insert the digital locking cylinder through the locking device from the outside in such a way that the outer thumb-turn is facing the outer side of the door. Fasten the cylinder into the mortise lock with the fastening screw.



NOTE

You must not strike the thumb-turns when installing the cylinder. Do not allow the cylinder to come into contact with oil, paint or acids.

6.3.2.3 Fastening the inside thumb-turn

Screw the inside thumb-turn onto the thread until it locks into place as it comes up against the cam. Pull on the inside thumb-turn, or push on the inside thumb-turn of a freely rotating AP cylinder, until it locks into position. Fasten the threaded pin tightly using the Allen key (1.5 mm).

6.3.2.4 Functional test

- To verify that the AP2 cylinder functions correctly in an anti-panic lock, you must check that the cam moves easily and that the door opens correctly using the procedure described below.
- Carry out the functional test in the direction of escape.
- You must carry out a functional test whenever the cylinder or the fastening screw is repositioned.
- You will need an authorised identification medium to carry out the functional test.
- Withdraw the dead bolt before the functional test.

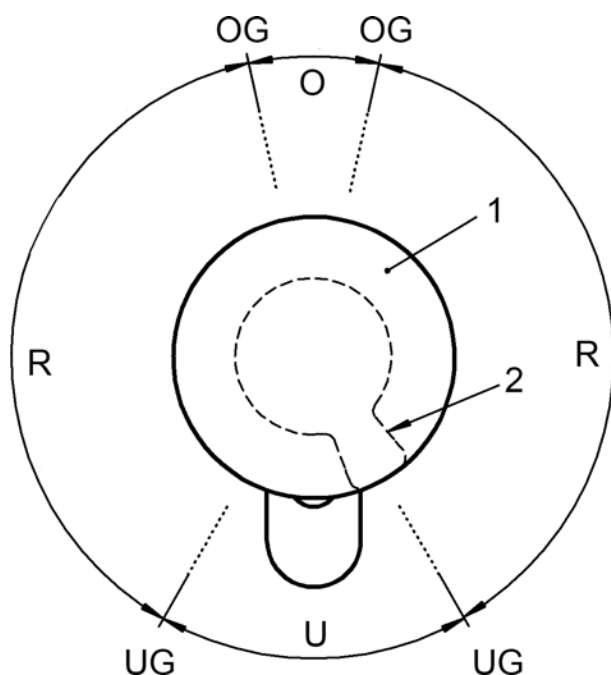

U section:	No restore force on the cam
R section:	Restore force section towards U section
O section:	Top dead point in deadbolt throw - no restore force on the cam
OG:	Top threshold section
UG:	Lower threshold section
1:	Thumb-turn
2:	Cam position (concealed)

1. With the cylinder engaged, first turn the thumb-turn in the direction of locking as far as the deadbolt throw in the 'R' section.
 - ↳ You will feel the restore force. When you release the thumb-turn in this position, it must turn back to the 'U' section of its own accord.
2. Lock the locking device and check the restore force. To do so, turn the engaged thumb-turn in the direction of locking through the 'R' section and into the 'O' section.
 - ↳ The dead bolt extends. There is no restore force in the 'O' section.
3. Move the thumb-turn slightly over the threshold between the 'O' and 'R' section in the same direction of rotation.
 - ↳ The dead bolt will extend. The restore force must turn the thumb-turn automatically from this point as far as the 'U' section if it is released.
 - ↳ If the thumb-turn does not automatically rotate as far as the 'U' section, either the fastening screw has been tightened too firmly or the locking device has been aligned incorrectly. The test is to be

repeated after the fault has been eliminated. A fastening screw which has been tightened too firmly acts as a brake on the restoring force mechanism.

4. Lock the door and check that the locking device functions correctly by pressing the door fitting or panic bar in the direction of escape.
 - ↳ The dead bolt must spring back and it must be possible to open the door easily.
 - ↳ If the dead bolt does not draw back when the handle is turned or the door fitting catches, either the locking cylinder or the locking device is incorrectly aligned or defective. The test is to be repeated after the fault has been eliminated as described above.

Please contact the lock manufacturer if you are unable to ensure that the locking device functions correctly after the functional test.

6.3.3 Installation of SKG/VdS cylinders

Loosen the outside knob's threaded pin using an Allen key. Do not unscrew completely. Hold the inside knob firmly and then turn the outside knob anti-clockwise.

Turn the cam until it is vertical and pointing downwards. Insert the digital locking cylinder through the lock from the inner side. Fasten the cylinder into the mortise lock with the fastening screw. Then screw the outside knob back into position on the cylinder and tighten the threaded pin.

IMPORTANT

Damage resulting from liquids

This product contains electronic and/or mechanic components that may be damaged by liquids of any kind.

- Keep liquids away from the electronics.

Violent action on the thumb turn

Don't strike the thumb turns when installing the cylinder.

6.3.3.1 Installation of core extraction protection adapters (Z4.KA.SET)

The core extraction protection adapter (Z4.KA.SET) is compatible with all SKG/VdS cylinders manufactured up to 2010 and all .FD cylinders.

Instructions:

1. Disassemble the non-electronic knob.
2. Remove the rubber seal on the tip of the outside tube.

3. Place the core extraction protection adapter on the outside tube and turn while applying a little pressure, so that it grips into the indents on the flange (in a similar way to the knob when installed). The openings in the adapter and the outside tube web must align.
4. Insert the supplied screw through the lock and tighten carefully.
5. Replace the knob and turn in an anti-clockwise direction while applying slight pressure until the outer knob grips into the indents in the flange. Possibly place the knob in this position by pressing it gently towards the profile cylinder housing.

**NOTE**

Turning the bayonet disc when not installed may prevent the thumb-turn from being fastened into position. In such a case, push the disc back into the original 'bayonet disc open' position using the installation tool.

6. Place the installation key on the outside thumb-turn in such a way that its two teeth engage into the outside thumb-turn (if necessary, turn the thumb-turn until both teeth lock into the locking disc). Lock the thumb-turn into position again by rotating it 30° in a clockwise direction.

6.3.3.2 Installation of core extraction protection adapters (Z4.KA.SET2)

The core extraction protection adapter (Z4.KA.SET2) is compatible with all SKG/VdS cylinders manufactured from 2011 onwards.

Instructions:

1. Disassemble the non-electronic knob.
2. Then screw the core extraction protection adapter into position on the cylinder and lock into place using the threaded pins.
3. Install the non-electronic knob on the core extraction protection adapter.

An elongated version of the adapter is available for the Italian market. (Z4.KA.SET2.IT).

6.3.4 Half Cylinder DK/MR

The thumb-turn, including the inside tube, can be removed from the cylinder housing to install the DK and MR versions. The procedure is described below. It is only necessary for key switches, for example, if the half cylinder cannot be installed using the fastening screw.

IMPORTANT

Damage resulting from liquids

This product contains electronic and/or mechanic components that may be damaged by liquids of any kind.

- Keep liquids away from the electronics.

Violent action on the thumb turn

Don't strike the thumb turns when installing the cylinder.

6.3.4.1 Installing the HZ cylinder

- ✓ PH2 SCREWDRIVER (or Z4.DM.SCREWDRIVER for DoorMonitoring variants)

1. Insert the half cylinder into the lock.

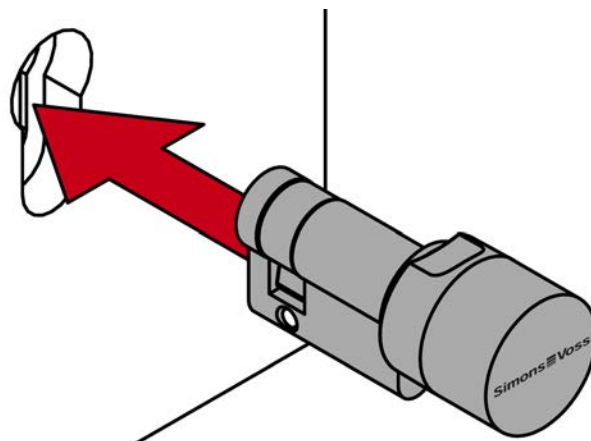

2. Affix the half cylinder with the fastening screw.

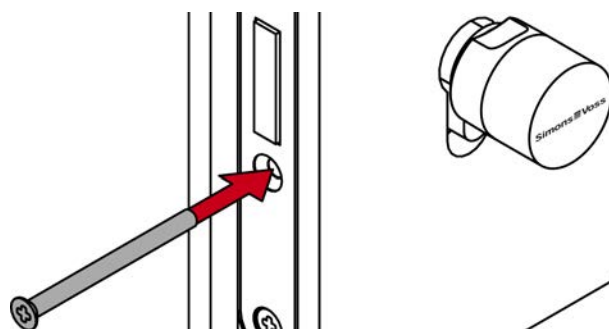

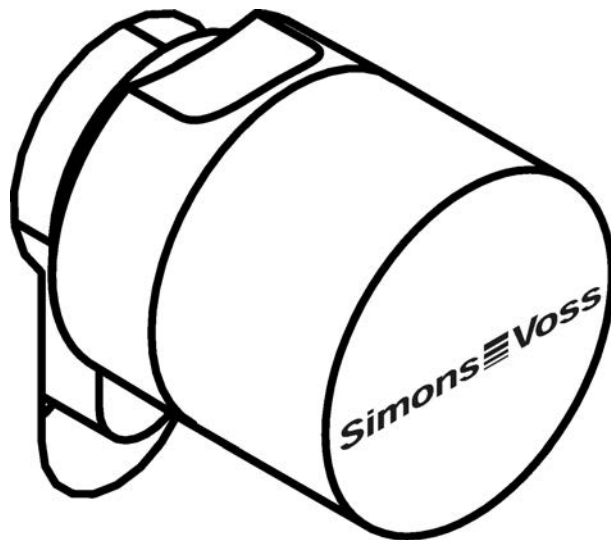

3. Carry out a function test.
↳ Cylinder fully installed.

6.3.4.2 Installing the HZ DK cylinder

The thumb-turn on .DK and MR cylinders can be removed for special escutcheon covers.

- ✓ Small slotted-head screwdriver
- ✓ PH2 SCREWDRIVER (or Z4.DM.SCREWDRIVER for DoorMonitoring variants)

1. Use the slotted-head screwdriver to break the plastic ring between the cylinder body and the thumb-turn.

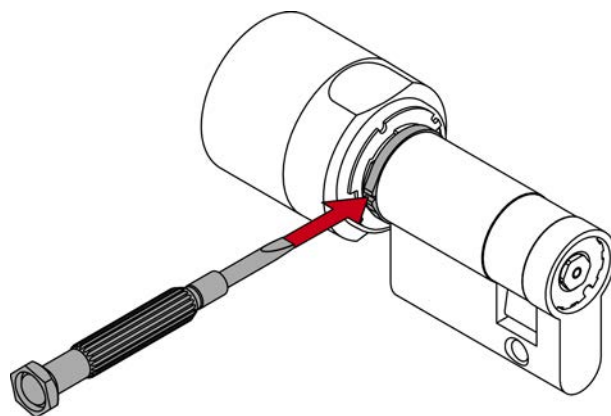

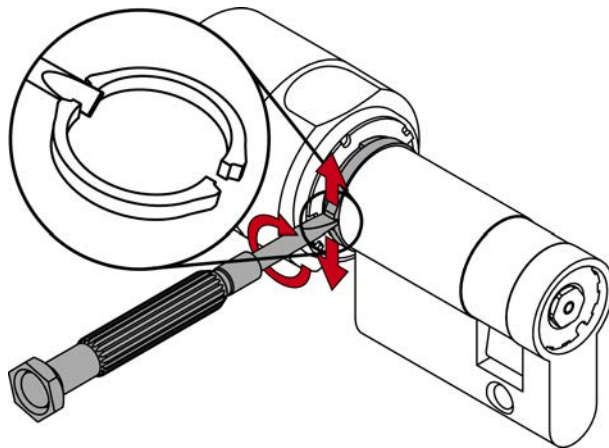

2. Engage the locking cylinder with an authorised identification medium.

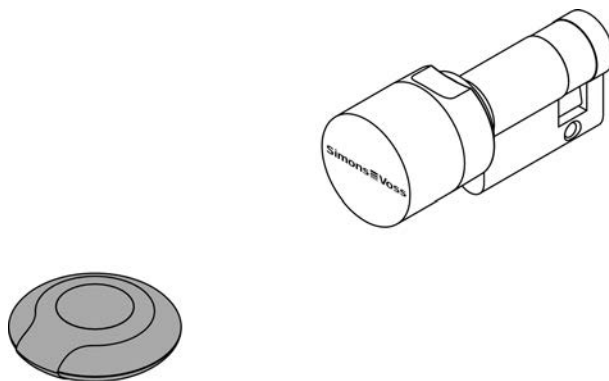

3. Push the thumb-turn into the cylinder body until it locks into position.
4. Hold the thumb-turn down and turn it anti-clockwise until it comes to a stop (hold cam if necessary).

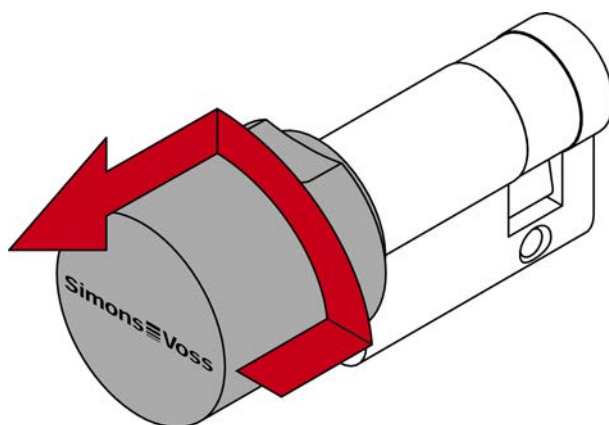

5. If the cylinder disengages while you are doing so, activate the identification medium again.
6. Pull the thumb-turn out of the cylinder body.

7. Pull off the existing rings (note order!).

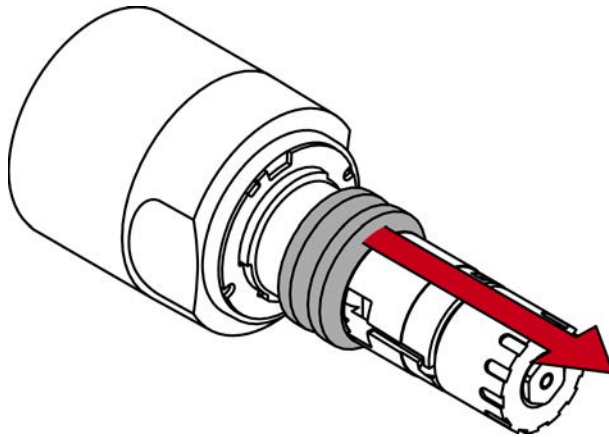

8. Insert the cylinder body through the door from the inside.

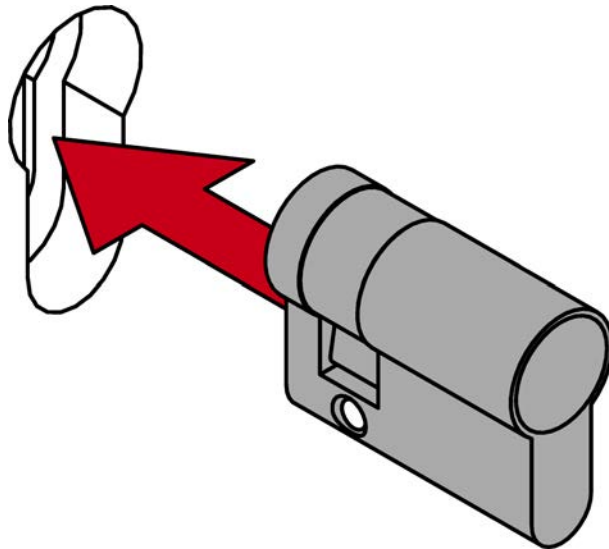

9. Affix the cylinder body with the fastening screw.

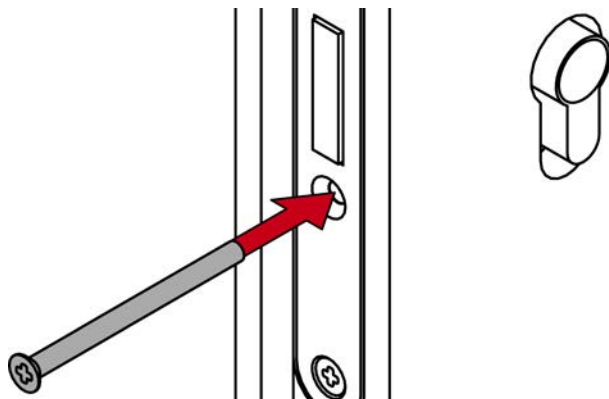

10. Fit the escutcheon onto the door.

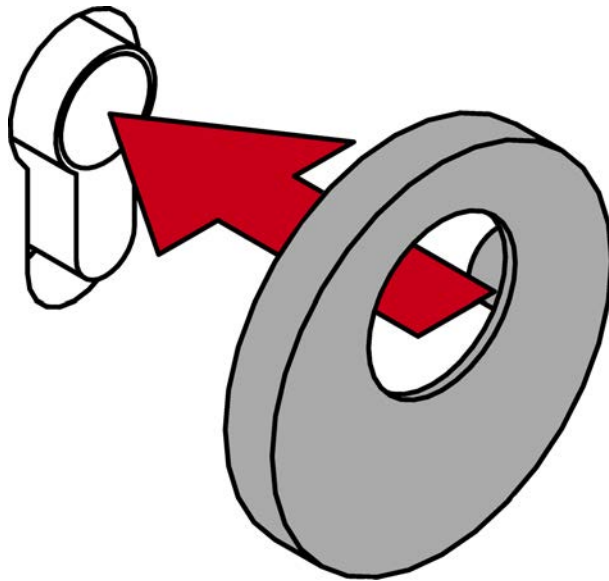

11. Insert the existing rings and a new plastic ring onto the thumb-turn spindle in the same order.

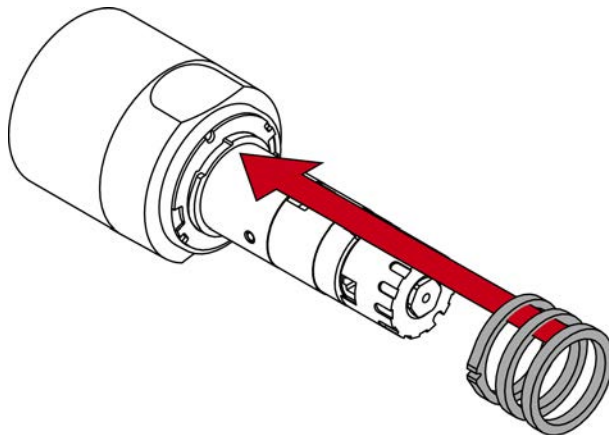

12. Reinsert the thumb-turn into the cylinder body.

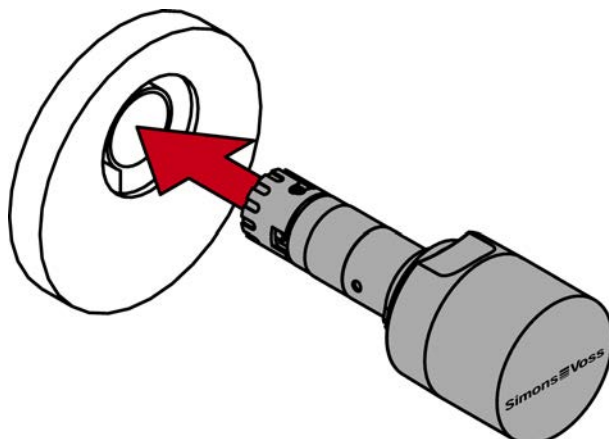

13. Engage the locking cylinder with an identification medium.

14. Press the thumb-turn into the cylinder casing and turn it clockwise until it locks into place.

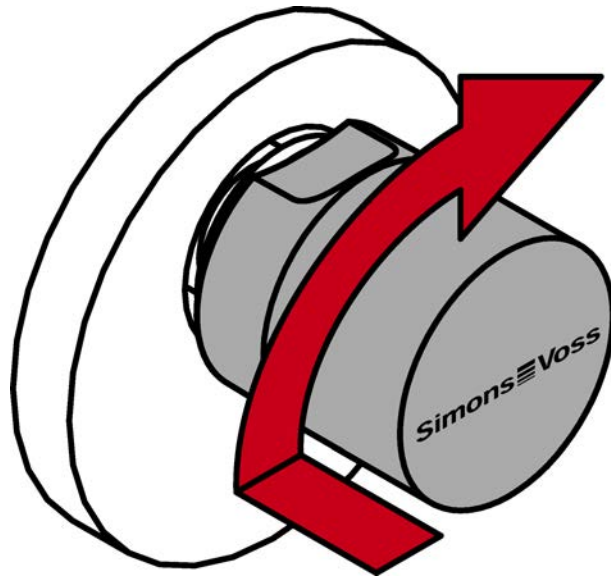

15. Check that the thumb-turn is into place by turning it back and forth.

↳ Cylinder fully installed.

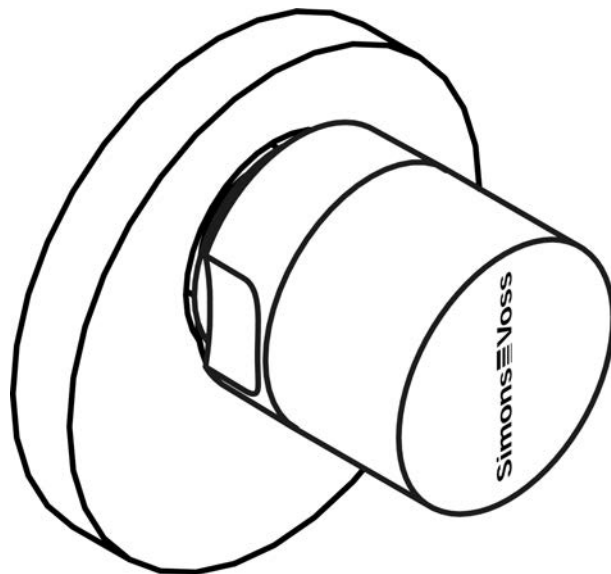

6.3.4.3 Disassembly

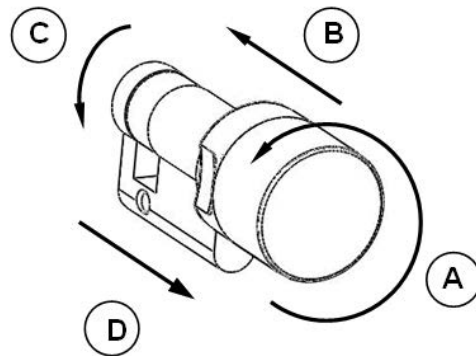

If you need to disassemble the half cylinder, please proceed as follows:

1. Using a tool such as a screwdriver, grip into the two slots in the plastic disc between the thumb-turn and the profile cylinder housing and turn the tool while applying a little pressure. This breaks the disc.
2. Remove the remains of the plastic disc.
3. Engage the half cylinder using an authorised ID medium.
4. While the thumb-turn is engaged, turn it anti-clockwise until it will turn no more (e.g. towards the lock when installed or holding the cam with your hand when not installed; see Step A in the diagram).
5. Press thumb-turn towards profile cylinder housing until it stops (you will hear it click. If necessary, move thumb-turn backwards and forwards several times until you hear a click; see Step B and D in the diagram).
6. If needed, engage the half cylinder once more using an authorised ID medium.
7. While the thumb-turn is engaged, turn it anti-clockwise and apply pressure against the stop position (see Step B and D in the diagram).
8. While applying pressure, pull the thumb-turn (including inside tube) from the profile cylinder (see Step D in the diagram).

**NOTE**

You must not strike the thumb-turn during installation. Do not allow the cylinder to come into contact with oil, paint or acids.

6.3.4.4 Functions test

1. Engage half cylinder using a valid ID medium and turn the thumb-turn in the locking and opening direction with the door open. The thumb-turn must be able to rotate easily when you do so.
2. Close the door and repeat the process. If the half cylinder should be stiff, you need to align the door or modify the strike plate.

This generally also applies when installing the cylinder in a key switch, for example.

6.3.5 Installing Swiss Round

Both cylinders and a fitting need to be removed from doors when installing a Swiss round cylinder.

The inside thumb-turn is removed and re-fitted in the same way as Half Cylinder DK / MR.

The outside knob is removed and re-fitted in the same way as the outside knob on a VdS cylinder.

1. Disassemble inside thumb-turn and outside thumb-turn. Remove a fitting from the door.
2. Push cylinder into the profile and fasten with the fastening screw.
3. Fit inside thumb-turn and outside thumb-turn. Mount fitting again.

IMPORTANT

Damage resulting from liquids

This product contains electronic and/or mechanic components that may be damaged by liquids of any kind.

- Keep liquids away from the electronics.

Violent action on the thumb turn

Don't strike the thumb turns when installing the cylinder.

6.3.6 Magnetic plate for DoorMonitoring

1. Clean the door frame in the area of the strike plate.
2. Stick the magnetic plate onto the door frame so that the faceplate screw is exactly opposite when closed.

6.4 Core extraction protection adapter

6.4.1 Installation Z4.KA & Z4.KA.SET

1. Dismount outside thumb turn with the aid of the installation tool.
2. Remove O-ring on the core tube with a suitable tool.
 - ↳ NOTE: The cylinder may not deform!
3. Apply adapter and turn while holding on to the thumb turn until it can be full pushed onto the core tube.
 - ↳ The cross hole of the adapter is flush with the cross hole of the core tube.

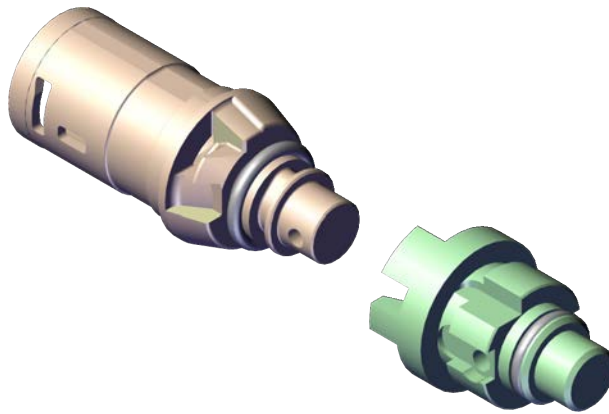

4. Insert the enclosed pin with the thinner side at the front of the side through the adapter hole on which the thread is to be seen.

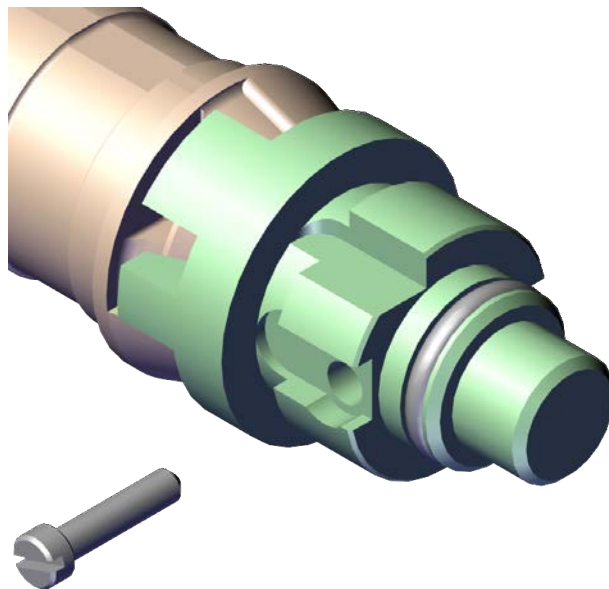

5. Fasten the pin with a suitable screwdriver.
↳ NOTE: The thread may not be destroyed.
6. Make sure that the pin does not protrude on any side of the adapter.

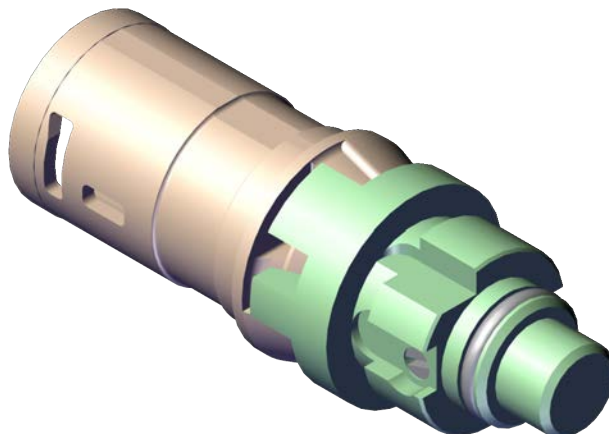

7. Mount the outside thumb turn with the aid of the installation tool.

6.4.2 Installation Z4.MP.KA.SET

Freely rotating, digital locking cylinders only (except AP2.FD).

1. Use the installation tool to remove the outer thumb-turn.
2. Attach core protection adapter. While holding the inside thumb-turn, rotate until the adapter locks into the locking cylinder, so that it is flush.
 - ↳ The notches on the core protection adapter now fit flush into those on the core tube.
3. Fasten core protection adapter using the supplied clip, as shown in the diagram:
 - ↳ The two markings point in the direction of the core protection adapter.
 - ↳ The clip must lock into position correctly on the core protection adapter.

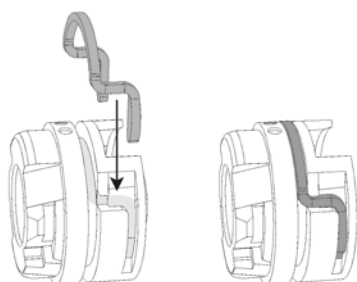

4. Check whether the clamp is fastened flush with the core protection adapter.
5. Push locking cylinder into the door from the inside.
6. Fasten locking cylinder with the fastening screw.
7. Use the installation tool to fit outer thumb turn to the locking cylinder.

6.5 Installing a LockNode



NOTE

Retrofitting of network caps (LNI) for knobs with button control (.TS) not recommended

The push-button makes it difficult to fit a network cap and the product may be damaged.

- SimonsVoss advises against retrofitting .TS cylinders with a network cap.

6.5.1 Installing a LockNode

- ✓ Cylinders manufactured after May 2008.
- 1. Place the battery/installation key on the electronic side thumb-turn so that the two noses engage in the openings of the locking disc (if necessary, turn the thumb-turn until the noses engage).



NOTE

The battery/installation key must lie flat on the inside of the thumb-turn.

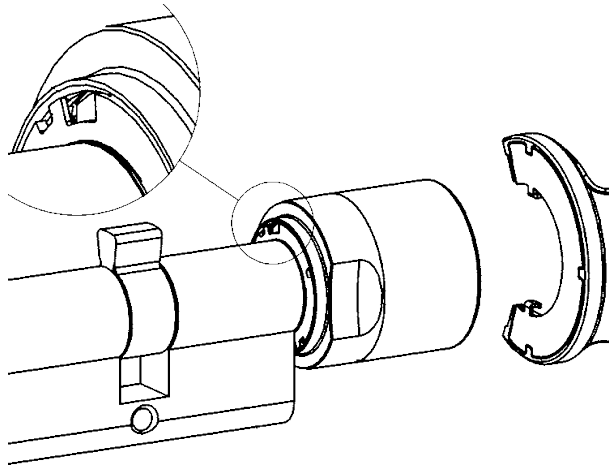

2. Hold the thumb-turn firmly and turn the battery/installation key clockwise about 30°.
 - ↳ The locking disc will click.
3. Push the recessed grip inwards.
4. Turn the thumb-turn cover counterclockwise until it stops.
5. Remove the thumb-turn cover.
6. Attach the thumb-turn cover with the LockNode as shown.

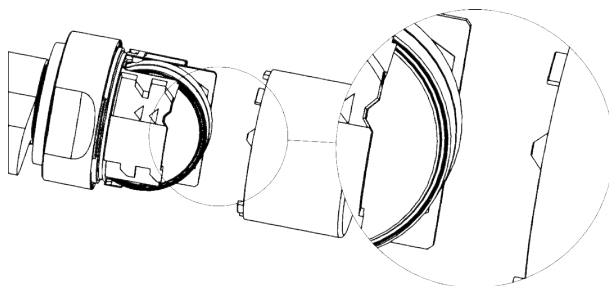

7. Turn the thumb-turn cover clockwise until it stops.
 - ↳ Cylinder beeps four times.
8. Pull the recessed grip outwards until it is flush with the thumb-turn cover.

9. Place the battery/installation key on the electronic side thumb-turn so that the two noses engage in the openings of the locking disc (if necessary, turn the thumb-turn until the noses engage).
10. Hold the thumb-turn firmly and turn the battery/installation key about 30° counterclockwise.
 - ↳ The locking disc will click.
 - ↳ LockNode is mounted.

If the cylinder does not beep, check the battery condition.

You can recognize a cylinder with LockNode by the black ring between the recessed grip and the thumb-turn cover.



6.5.2 Installing a LockNode MP

1. Place the battery/installation key on the electronic side thumb-turn so that the two noses engage in the openings of the locking disc (if necessary, turn the thumb-turn until the noses engage).



NOTE

The battery/installation key must lie flat on the inside of the thumb-turn.

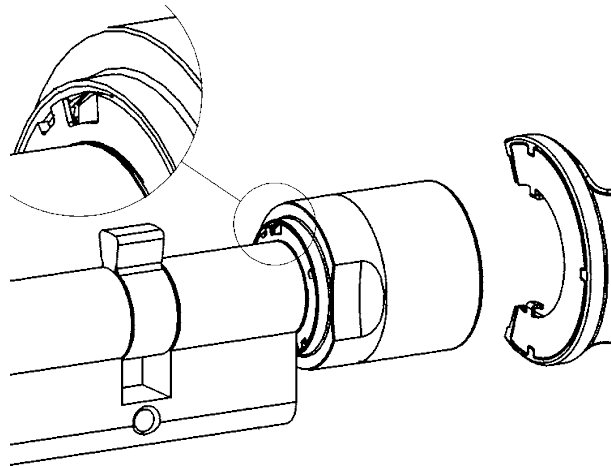

2. Hold the thumb-turn firmly and turn the battery/installation key clockwise about 30°.
↳ The locking disc will click.
3. Push the recessed grip inwards.
4. Turn the thumb-turn cover counterclockwise until it stops.
5. Remove the thumb-turn cover.
6. Carefully bend the black plastic holders outwards.

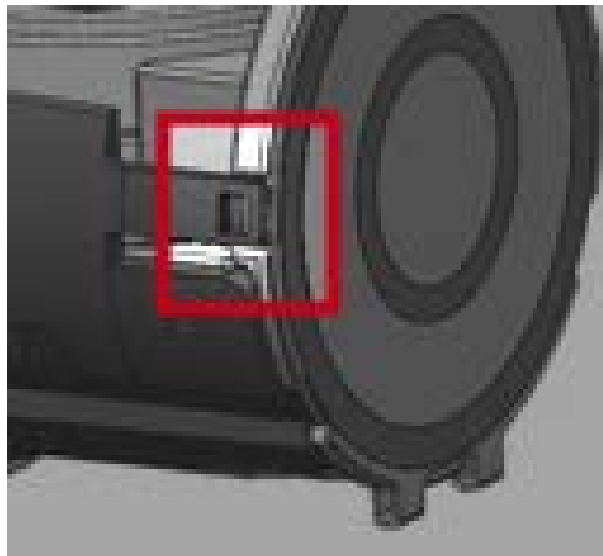

↳ Card reader cover pops open.

7. Push the LockNode about halfway into the designated slots.

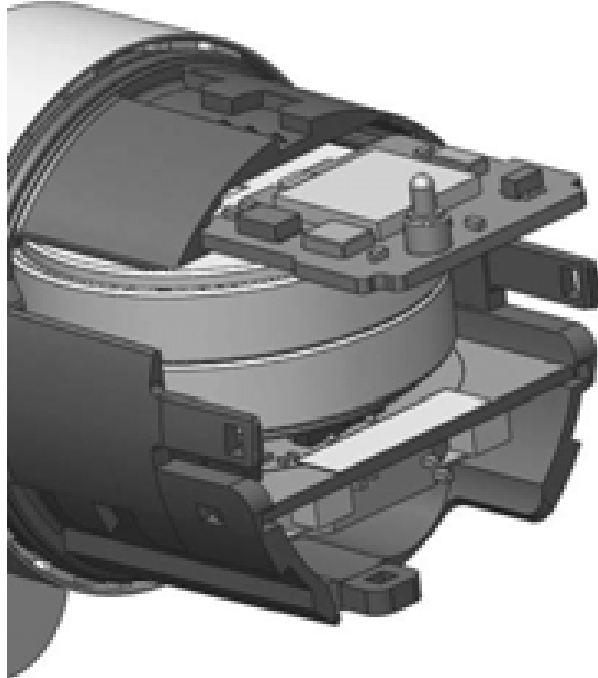

8. Close the card reader cover and press it firmly until it snaps into the black plastic holders.

↳ LockNode is fixed.



9. Attach the supplied thumb-turn cover with the glued-in contact foil (pay attention to the markings).

↳ Cylinder beeps four times.

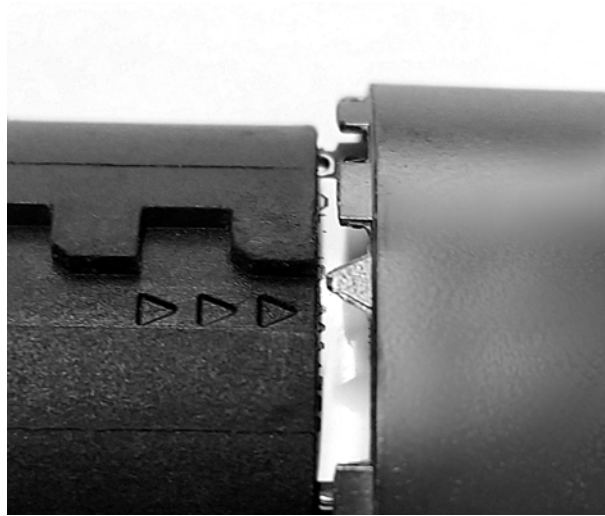

10. Turn the thumb-turn cover clockwise until it stops.
 11. Pull the recessed grip outwards until it is flush with the thumb-turn cover.
 12. Place the battery/installation key on the electronic side thumb-turn so that the two noses engage in the openings of the locking disc (if necessary, turn the thumb-turn until the noses engage).
 13. Hold the thumb-turn firmly and turn the battery/installation key about 30° counterclockwise.
 - ↳ The locking disc will click.
 - ↳ LockNode is mounted.
- If the cylinder does not beep, check the battery condition.

7. Audible signals

The Locking Cylinder 3061 emits an audible signal to indicate its status and an authorisation. The table below lists what the audible signals mean.

2 short audible signals before engaging and a short tone after disengaging.	Normal activation	None
1 short audible signal: cylinder does not engage.	<p>Attempted entry with a transponder listed in the locking system, but:</p> <ul style="list-style-type: none"> ■ used outside time zone. ■ Activated alarm system while using the SimonsVoss Block Lock. 	None
Battery Warning Level 1: 8 short audible signals before engaging.	Batteries are low.	Replace batteries in the cylinder.
Battery Warning Level 2: 8 short audible signals 30 seconds long with one second pause each time before engaging.	Batteries are almost completely empty.	Replace batteries in the cylinder immediately.
Freeze mode (G2 only): 6 audible signals (long – pause – short).	Battery empty. Cylinder can no longer be opened using an authorised transponder. Cylinder can only be engaged using a battery replacement transponder.	Replace batteries and reset with a battery replacement transponder.
8 short audible signals after disengaging.	Transponder battery is low.	Have transponder battery replaced.

7.1 Battery warnings

A battery management system has been implemented in locking cylinders and transponders which warns the user in good time that the battery capacity is diminished. This prevents the batteries from becoming fully discharged. The individual battery warning levels are described below.

The locking cylinder batteries feature a redundant system. If one of the batteries fails or its capacity falls below a certain level, the system emits a battery warning.

The battery warning levels between G1 and G2 differ after Battery Warning Level 2 if the battery capacity falls under the emergency battery warning threshold values.

■ Warning Level 1: Low batteries

If the charged capacity falls below 25% in one of the batteries, Battery Warning Level 1 is activated. After you activate the transponder, you will hear eight brief audible signals in rapid succession before the cylinder engages. You must replace the batteries.

■ Warning Level 2: Extremely low batteries

If the locking cylinder batteries discharge even further, short audible signals are heard in rapid succession for about 30 seconds before the cylinder engages after the transponder is activated. The cylinder does not engage until the audible signals have finished. The batteries should be replaced as quickly as possible.

If this warning level is ignored, the locking cylinder switches to what is known as storage or freeze mode.

<p>■ Emergency battery – Storage mode (G1 cylinders):</p> <p>In storage mode, the cylinder can only be opened with the aid of a programming device (SmartCD).</p>	<p>■ Emergency battery – Freeze mode (G2 cylinders):</p> <p>In freeze mode, an audible signal will sound if an attempt is made to open using an authorised transponder, but the cylinder will not engage.</p> <p>The G2 cylinder can now only be opened using a battery replacement transponder or programming device.</p> <p>■ Active locking devices: The system administrator can use a G2 battery replacement transponder (freeze mode transponder) for about 30 seconds to eliminate freeze mode and open the door with a user transponder to replace the batteries.</p> <p>■ SmartCard locking devices: The system administrator can use a "G2 battery replacement card" (freeze mode card) to permanently eliminate the freeze mode (including warning levels) and open the door to change the batteries using a user identification medium.</p>
---	---



NOTE

After using a "G2 battery replacement medium" on locking devices, change the batteries immediately. Otherwise, the locking device may fail completely due to empty batteries.

	WARNING LEVEL 1	WARNING LEVEL 2	FREEZE MODE
Active cylinder:	8 short audible signals before engaging	Eight short audible signals 30 seconds long with one second pause each time before engaging	6 audible signals (long – pause – short)

	Up to 15,000 access events or up to 9 months on standby	Up to 50 access events or up to 30 days	Battery replacement: activate with battery replacement transponder
Cylinder SC (transponder use):	8 short audible signals before engaging	Eight short audible signals 30 seconds long with one second pause each time before engaging	6 audible signals (long – pause – short)
Cylinder SC (SmartCard use):	LED flashes red briefly 8 times before engaging	LED flashes red briefly twice for 30 seconds before engaging	LED flashes red once and blue once
	Up to 300 access events or up to 30 days	Up to 200 access events or up to 20 days	Battery replacement: activate with battery replacement transponder

7.2 Battery warning for transponders

When the transponder battery is low, short audible signals are heard in rapid succession on the locking cylinder (not the transponder) after the locking cylinder disengages each time the transponder is used.

8. System 3060 battery replacement

8.1 General instructions

Only trained personnel may replace the batteries.

You must wear clean gloves made of cloth and free of fat or grease when replacing the batteries to prevent the batteries being contaminated by fingerprints. Fingerprints on batteries may reduce battery life considerably.

Only use batteries which have been approved by SimonsVoss.



NOTE

You may cause damage to the Locking Cylinder 3061 if you reverse the polarity. The batteries used in this device may pose a fire or burn hazard if handled incorrectly. Do not recharge, open or burn batteries, or heat them to over 100° C.



NOTE

Dispose of lithium batteries properly immediately after they have discharged. Store them out of children's reach; do not open and do not throw into a fire. Always replace both batteries when changing batteries. Please note safety instructions.

The locking cylinder retains its status, programming and saved protocols even without power supply.

8.2 Battery life

Battery life is different for each locking cylinder version as power consumption varies when the cylinder is activated or a data connection is established.

VERSION	BATTERY LIFE	NUMBER OF ACTIVATIONS	NUMBER OF BATTERIES
Standard cylinder and versions	Up to 10 years	Up to 300,000	2
WN (LNI / Lock-Node)	Up to 5 years	Up to 150,000	2

The specified battery life is for guidance only. A battery warning is not emitted when the aforementioned battery life expires, but is based on the measured battery status instead.

8.3 Emergency battery procedure

As stated above, a locking cylinder changes to storage mode (G1) or freeze mode (G2) if Battery Warning Level 2 is ignored. A different procedure is used each for G1 and G2 to eliminate this mode.

8.3.1 Storage mode (G1)

If the locking cylinder is in emergency battery storage mode, proceed as follows to open the door to change the battery and reset the cylinder.

1. Take notebook or PDA (import locking plan beforehand) and programming device to the door in question.
2. Select the corresponding lock from the locking plan.
3. Re-programme locking cylinder without making any modifications. This eliminates the battery warning and storage mode.
4. Engage the locking cylinder using an authorised transponder and open the door. The cylinder will immediately revert to storage mode, as both batteries are almost empty.
5. Renew batteries (see below).
6. Re-programme locking cylinder without making any modifications. This eliminates the battery warning check marks and storage mode.
7. Engage the locking cylinder using an authorised transponder.

After battery replacement, the locking cylinder signals Warning Level 2 again. The locking cylinder's electronics then detect that the batteries are fully charged or have been replaced and the cylinder is available for normal use again.

8.3.2 Freeze mode (G2)

Emergency opening of the door and elimination of emergency retention mode in G2 is easier than G1 generation systems.

1. Programme the G2 battery replacement transponder if necessary.
2. Deactivate freeze mode using the G2 battery replacement transponder.
3. Use an authorised transponder to engage the locking cylinder and open the door.
4. Replace the battery.
5. Deactivate freeze mode using the G2 battery replacement transponder.
6. Perform an opening transaction on the locking cylinder with an authorised transponder to test that it is functioning and eliminate freeze mode.

**NOTE**

Only use the G2 battery replacement transponder to deactivate freeze mode and then immediately replace the cylinder batteries. Misuse may lead to complete battery discharge and, consequently, a complete failure of the cylinder.

8.4 Procedure

1. Place the installation/battery key on the inside thumb-turn in such a way that the two teeth lock into the openings in the locking disc; if necessary, turn the thumb-turn until both teeth engage into the locking disc.

**NOTE**

The tool must be placed flat on the inside front surface of the recessed grip ring to ensure that the installation/battery key can engage into the locking disc.

2. Hold the inside thumb-turn firmly and carefully turn the installation/battery key about 30° in a clockwise direction (until you hear a click).
3. Remove installation/battery key from the thumb-turn.
4. Push recessed grip ring backwards towards the door, so that it comes away from the thumb-turn.
5. Hold recessed grip ring firmly and turn thumb-turn about 10° in an anti-clockwise direction and remove.
6. For MH cylinders only: Carefully fold antenna upwards.
7. Carefully remove both batteries from the holder.

8. Insert the new batteries into the holder at the same time with the positive poles next to each other; change the batteries as quickly as possible. Use clean gloves free of fat or grease to handle new batteries.

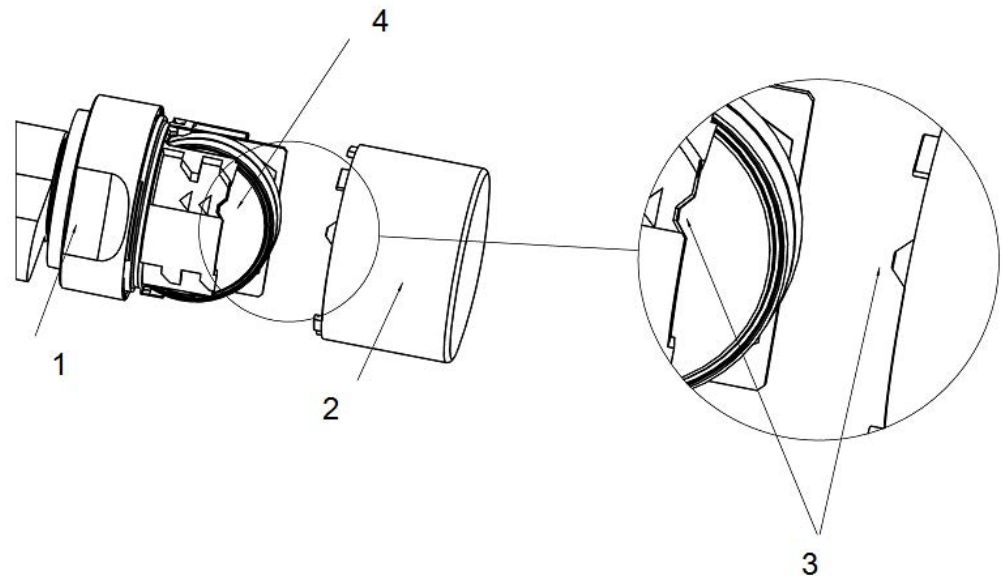

9. For MH cylinders only: Lock antenna back into place.
10. Replace the thumb-turn (align the triangle mark as in the diagram), hold the recessed grip ring firmly and fasten the inside thumb-turn by turning in a clockwise direction (about 10°). (Diagram may differ slightly from the purchased product)
11. Push recessed grip ring back onto the thumb-turn, so that the thumb-turn and ring close together in a flush fit.
12. Place the installation/battery key on the inside thumb-turn in such a way that the two teeth lock into the openings in the locking disc; if necessary, turn the thumb-turn until both teeth engage into the locking disc.
13. Close the thumb-turn again by turning it about 30° in a clockwise direction (until you hear a click).

Then activate an authorised ID medium and check that it functions.

8.5 Procedure for outer thumb turn (MH cylinder)

4 batteries are built into the MH cylinder: 2 in the inside thumb-turn, 2 in the outer thumb-turn.

Proceed as follows to replace the two batteries:

1. Use the battery replacement key to detach the outer thumb-turn. To do so, face the outer thumb-turn and place the battery replacement key on the bayonet mount and turn in a clockwise direction until you can remove the thumb-turn easily.
 - ↳ The outer thumb-turn is now fully detached.
2. Place the battery replacement key on the detached thumb-turn again and open the bayonet mount completely (*turn in an anti-clockwise direction as you face the mount*). You may be able to skip this step.
 - ↳ The lid springs open by itself as the bayonet mount is unscrewed.
3. Carefully lift off the lid.
 - ↳ The lid is attached to the thumb-turn with a small securing strap and a ribbon cable; the batteries are now exposed.
4. Insert new batteries in such a way that the two plus poles lie flat on one another and then position in the thumb-turn.

**NOTE**

You should always replace both batteries with new ones when changing the batteries.

**NOTE**

You must place the ribbon cable loop crossways directly under the thumb-turn lid.

5. Reattach lid to the outer thumb-turn and press gently.
 - ↳ The lid is now flush against the outer thumb-turn.
6. Use the battery replacement key to lock the bayonet mount to a minimum extent until the lid locks into the outer lid of its own accord. (about 1° in a clockwise direction)
7. Re-attach outer thumb-turn onto the locking cylinder.
 - ↳ The outer thumb-turn is now flush against the locking cylinder.
8. Now use the battery replacement key to lock the bayonet mount completely. To do so, face the outer thumb-turn and place the battery replacement key on the bayonet mount and turn in an anti-clockwise direction until the thumb-turn is firmly in position.
9. Check that the outer thumb-turn is firmly attached again and test the locking cylinder function to ensure that it works.

9. Maintenance, cleaning and disinfection



NOTE

Digital locking cylinders **MUST** not come into contact with oil, grease, paint or acids.



NOTE

The use of unsuitable or aggressive disinfectants can damage the locking cylinder.

Clean the locking cylinder if necessary with a soft, moist cloth.

Only use disinfectants explicitly suitable for the disinfection of sensitive metal surfaces and plastic.



NOTE

HZ.SL: *It is recommended to grease the latching edge on the electrical enclosure lever handle.*

Empty batteries always must be replaced by new ones approved for use by SimonsVoss. Dispose of old batteries in the proper manner.

Carry out a new functional test after changing the batteries in anti-panic cylinders.

10. Areas of use

10.1 General

The digital locking cylinder is compatible with locks for Euro profile cylinder as per DIN 18252 and EN1303.

10.2 Fire doors

As a general rule, this cylinder can be fitted into fire doors. However, you must check that it is actually approved for use in fire doors.

10.3 Doors along rescue routes

Type .AP should be installed for use in doors with an anti-panic function in which the position of the cam may have an effect on the lock's functioning. This must be specified in the lock manufacturer's approval. Also see industrial standards EN 179 and EN 1125 and the individual lock manufacturers' data sheets.

10.4 Installation outdoors

If you are unable to ensure that no water will come through the door, we recommend using the respective .WP versions. The outer thumb-turn is completely sealed in the anti-panic cylinder model and the whole cylinder is sealed in the double thumb-turn cylinder variant.

11. Accessories

11.1 Thumb-turns

The following special thumb-turns are available as accessories:

- Outer thumb-turn in a TN4 design
- Outer thumb-turn, 42 mm in diameter with recessed grips
- Inside thumb-turn, 36 mm in diameter for a .TS cylinder
- Outer thumb-turn, shortened
- Brass thumb-turn, matt (inside and outer thumb-turn)

These thumb-turns can replace the original locking cylinder thumb-turns at any time. See Installation instructions or Battery replacement for thumb-turn installation.

11.2 Core extraction protection adapter (Z4.KA.SET)

This adapter is compatible with all SKG/VdS cylinders manufactured up to 2010 and all .FD cylinders.

There is a mechanical extension for core extraction protection fittings as the profile cylinder profile is not cut out of these fittings. The extension is 8 mm long and can be retrofitted at any time.

11.3 Core extraction protection extension for SKG/VdS cylinders (Z4.KA.SET2)

This adapter is compatible with all SKG/VdS cylinders manufactured in 2011 and onwards.

There is a mechanical extension for core extraction protection fittings as the profile cylinder profile is not cut out of these fittings. The extension is 8 mm long and can be retrofitted at any time.

11.4 Core extraction protection extension for SKG/VdS cylinders (Z4.KA.SET2.IT)

This adapter is compatible with all SKG/VdS cylinders manufactured in 2011 and onwards.

There is a mechanical extension for core extraction protection fittings as the profile cylinder profile is not cut out of these fittings. The extension length is 16 mm for special Italian escutcheons and can be retrofitted at any time.

11.5 Tool

In addition to the installation tool, a battery replacement key is also included in the supply package. You can use this tool to install or remove outer thumb-turns and replace batteries.

11.6 Battery set

A new set of batteries can be ordered, which contains ten CR2450 batteries. Only ever use batteries approved by SimonsVoss.

12. Technical data

Radio emissions

24.50 kHz - 25.06 kHz Only for item numbers: Z4.*, Z4.*MH*	-20 dB μ A/m (10 m distance)
13.564 MHz - 13.564 MHz Only for item numbers: Z4.*MH*, Z4.*MP*	-19.57 dB μ A/m (10 m distance)

12.1 Locking cylinder

Profile cylinder

Basic length:	Outside 30 mm, internal 30 mm (AP/WP 35mm)
---------------	---

Installation lengths in 5 mm increments, overall length up to 140 mm (max. 90 mm on one side); special lengths on request.

Batteries

Type:	CR, 2450, 3 V
Manufacturer:	Murata, Panasonic
Quantity:	2 units
Battery life:	up to 300,000 lock operations or up to 10 years on standby

Ambient conditions

Operating temperature:	-25°C to +65°C
Storage temperature:	-35°C to +50°C
Protection class:	Standard protection rating IP54 (when installed); .WP variant: IP66
Air humidity:	<95%: non-condensing

Features

- 3,000 access events can be logged (ZK)

- Network-ready with integrated LockNode (WN)
- LockNode can be retrofitted
- Time zone groups: G1: 5 / G2: 100
- Max. number of transponders per G1 Cylinder: 8000 / G2: 64,000
- Different permanent/open modes

Thumb-turns

Material:	Stainless steel
Colours:	Stainless steel, brushed
Diameter:	30 mm
Length:	37 mm (from front surface of profile)

FH cylinder thumb-turns

Material:	Inside thumb-turn: stainless steel cover; recessed grip: plastic; outer thumb-turn: identical to standard cylinders
Colours:	Cover: brushed stainless steel; recessed grip: black; outside thumb-turn identical to standard cylinders
Diameter:	30 mm
Length:	37 mm (from front surface of profile)

AP cylinder thumb-turns

Material:	Outside thumb-turn: identical to standard cylinders: Aluminium
Colours:	Outside thumb-turn: Brushed stainless steel; internal thumb-turn: Nickel-coated aluminium
Diameter:	30 mm
Length:	Outside: 37 mm (from front surface of profile); internal: about 36 mm (from front surface of profile)

MS cylinder thumb-turns

Material:	Outside thumb-turn: identical to standard cylinders; internal thumb-turn: identical to standard cylinders
Colours:	Outside thumb-turn: Cover made of high-gloss brass; recessed grip: matt brass; internal thumb-turn: Cover made of high-gloss brass; recessed grip: Matt brass
Diameter:	30 mm
Length:	Outside: 37 mm (from front surface of profile)

12.2 Half cylinder

Thumb-turns

Material:	Stainless steel
Colours:	Stainless steel, brushed
Diameter:	30 mm
Length:	37 mm (from front surface of profile)

Profile cylinder

Basic length:	outside 30 mm, internal 10 mm
---------------	-------------------------------

Installation lengths in 5 mm increments (no installation kit) an overall length of up to 100 mm with a maximum length of 90 mm on the outer side of the cylinder. Greater lengths on request.

Batteries

Type:	CR, 2450, 3 V
Manufacturer:	Murata, Panasonic
Quantity:	2 units
Battery life:	up to 300,000 lock operations or up to 10 years on standby

Features

- 3,000 access events can be logged (ZK)
- Network-ready with integrated LockNode (WN)

- LockNode can be retrofitted
- Time zone groups: G1: 5 / G2: 100
- Max. number of transponders per G1 Cylinder: 8000 / G2: 64,000
- Different permanent/open modes

Ambient conditions

Operating temperature:	-25°C to +65°C
Storage temperature:	-35°C to +50°C
Protection class:	Standard protection rating IP54 (when installed); .WP variant: IP66 thumb-turn
Air humidity:	<95%: non-condensing

Cam HZ.SL

Cam position handle:	37°
Cam width from neutral position:	11 mm

12.3 Dimensional drawings cylinder

Thumb-turn front view - Active

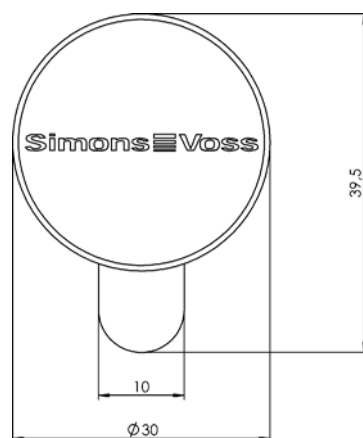

Comfort - Active (CO)

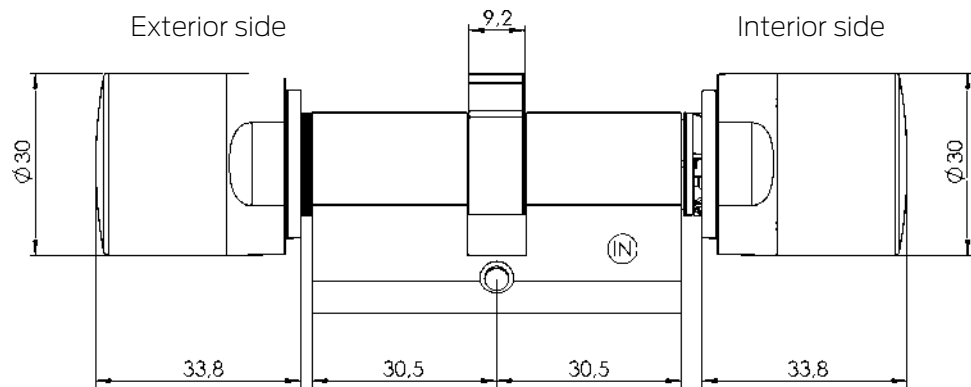

Comfort - Passive (CO MP)

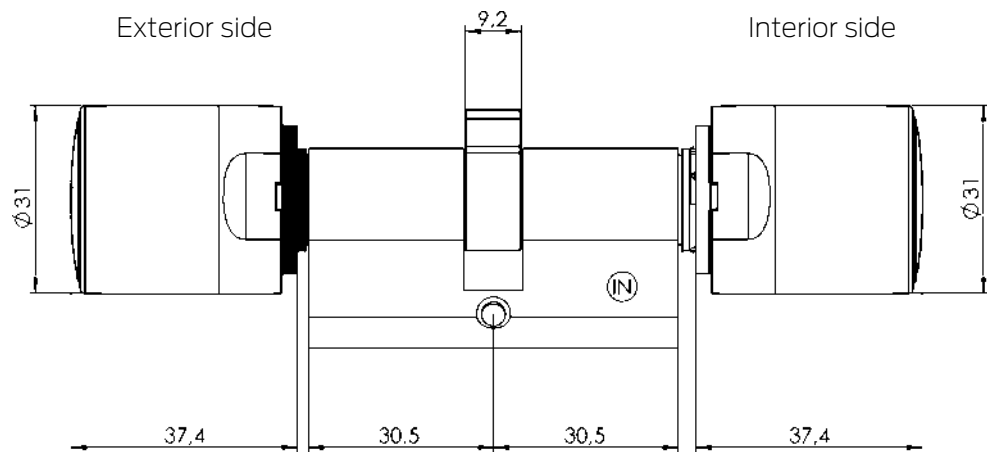

Freely rotating - Active (FD)

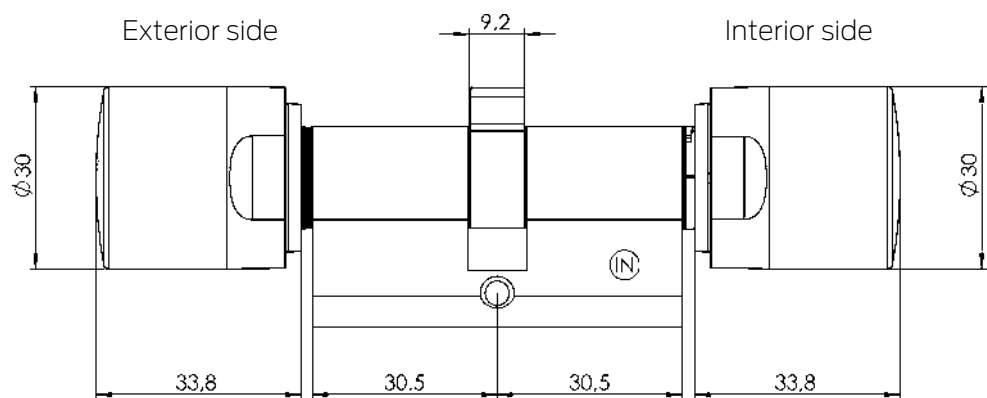

Freely rotating - Passive/hybrid (FD MP/MH)

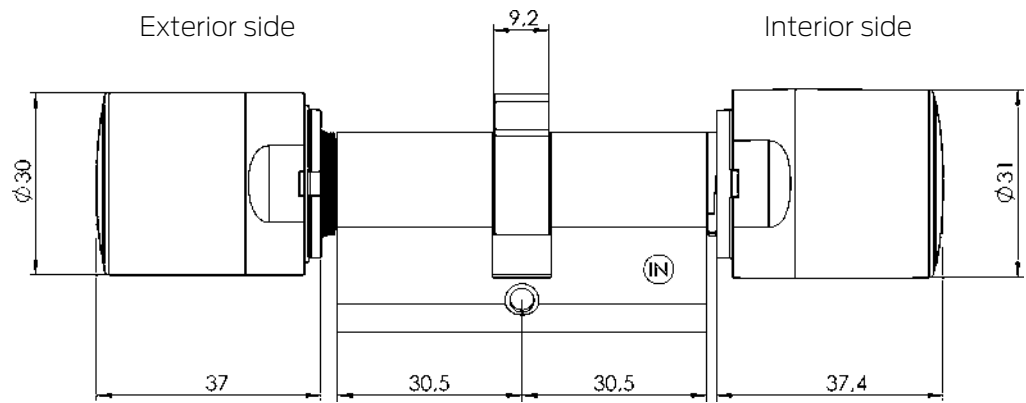

Half cylinder - Active (HZ)

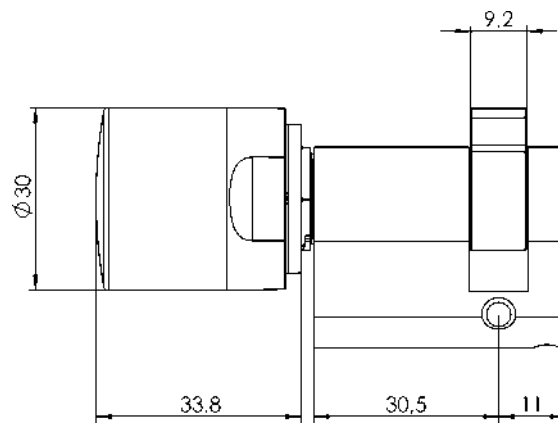

Half Cylinder - Passive (HZ MP)

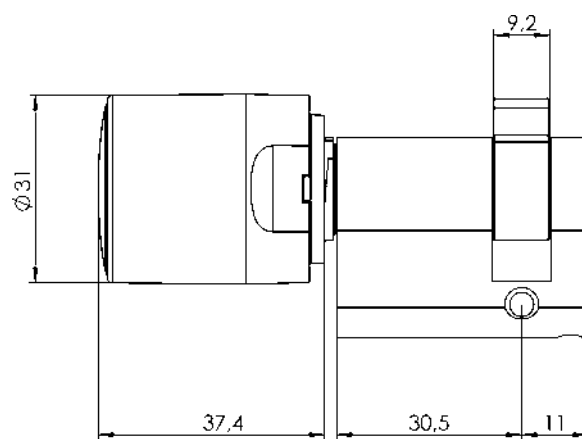

DoorMonitoring - Active (DM)

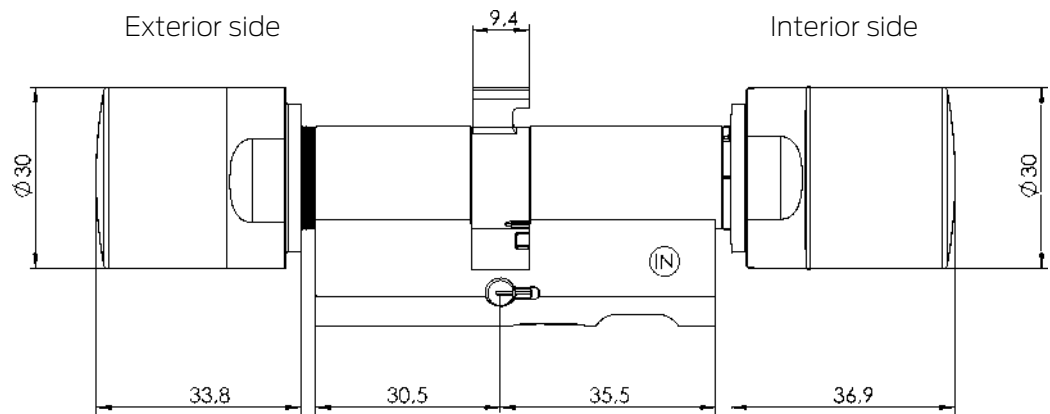

DoorMonitoring half cylinder Active (DM HZ)

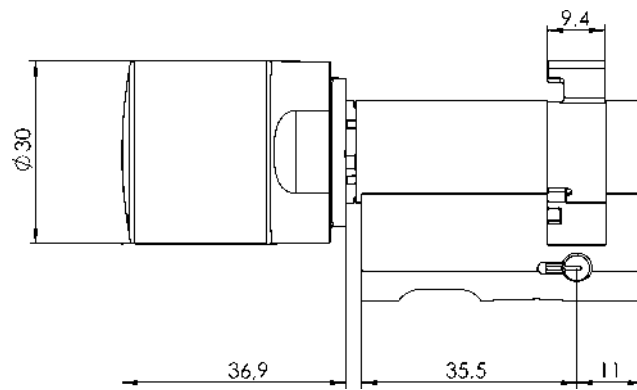

Anti-panic Freely rotating - Active (AP2 FD)

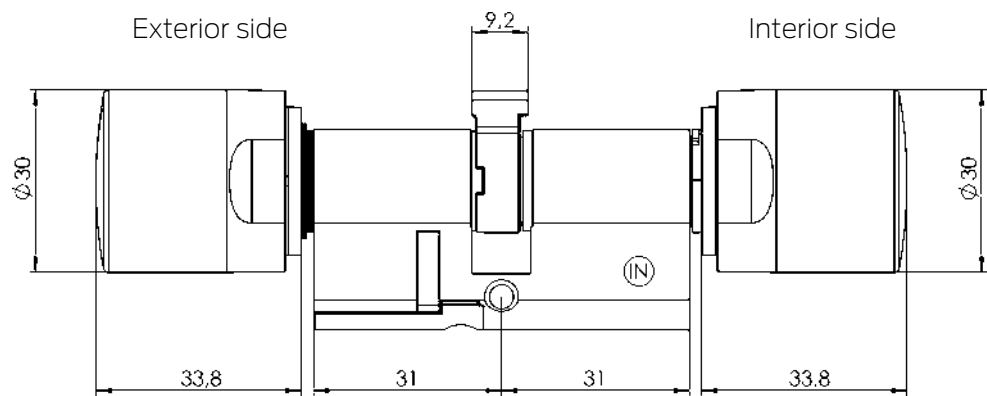

Anti-panic Free rotating - passive (AP2 FD MP)

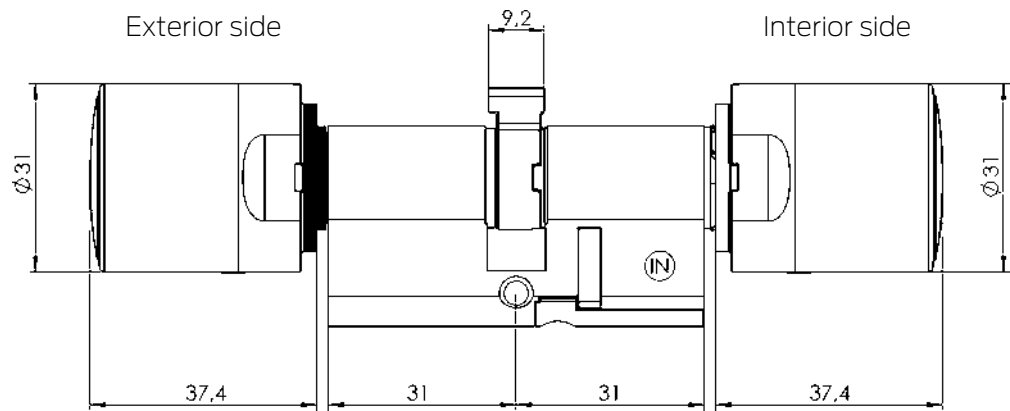

Anti-panic Reader on both sides - Passive (AP2 BL MP)

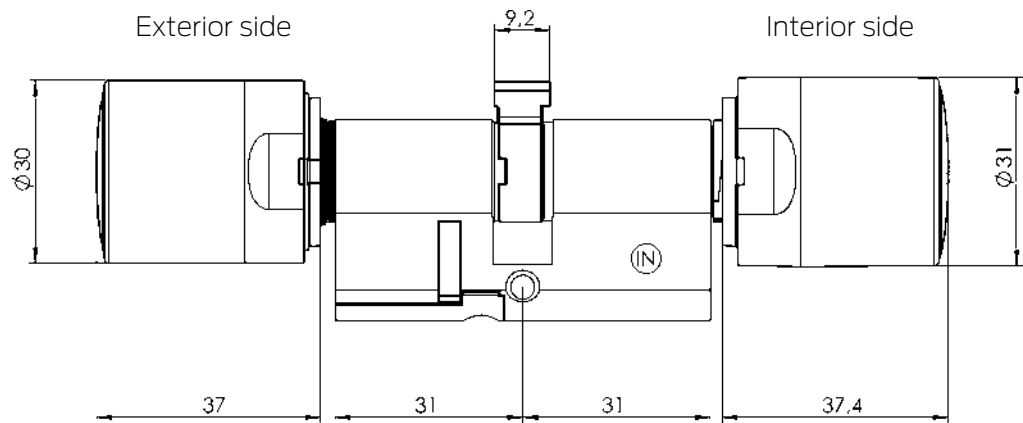

Scandinavian Oval - Active (SO)

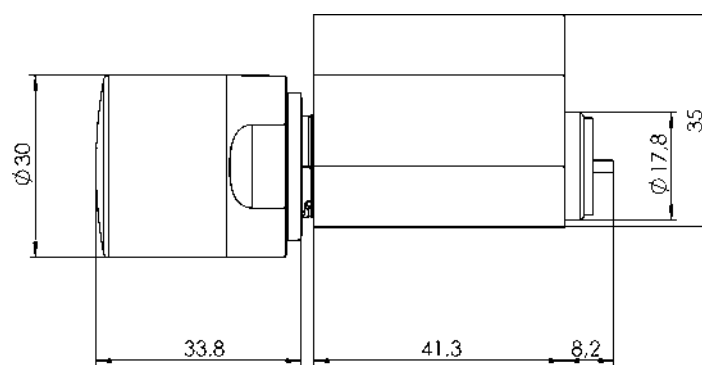

Scandinavian Oval - Passive (SO MP)

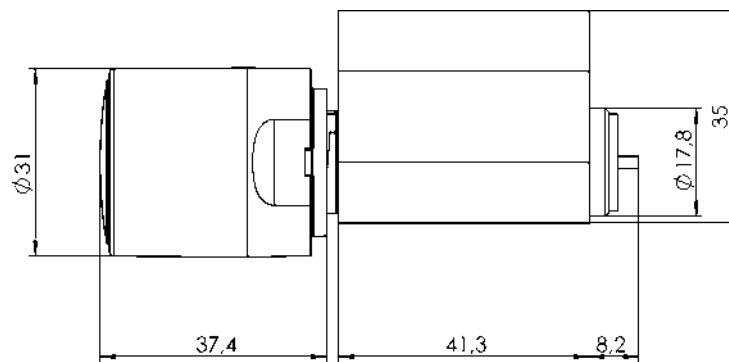

Scandinavian Round - Active (RS)

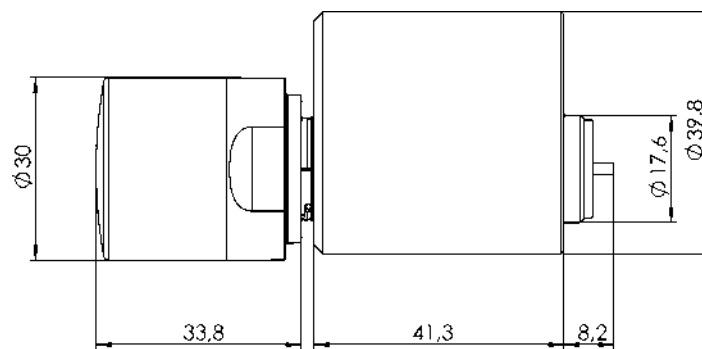

Scandinavian Round - Passive (RS MP)

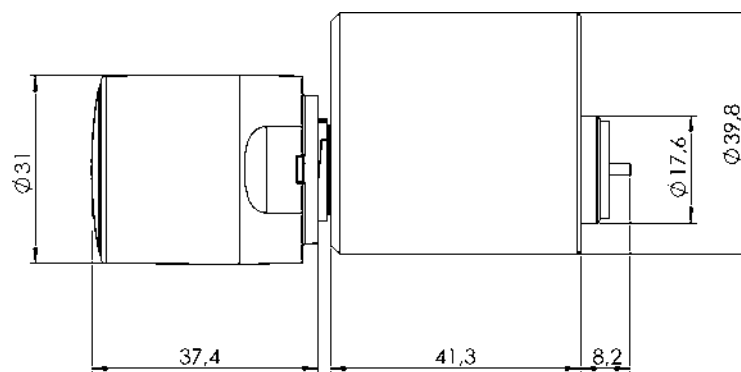

Swiss Round Comfort - Active (SR CO)

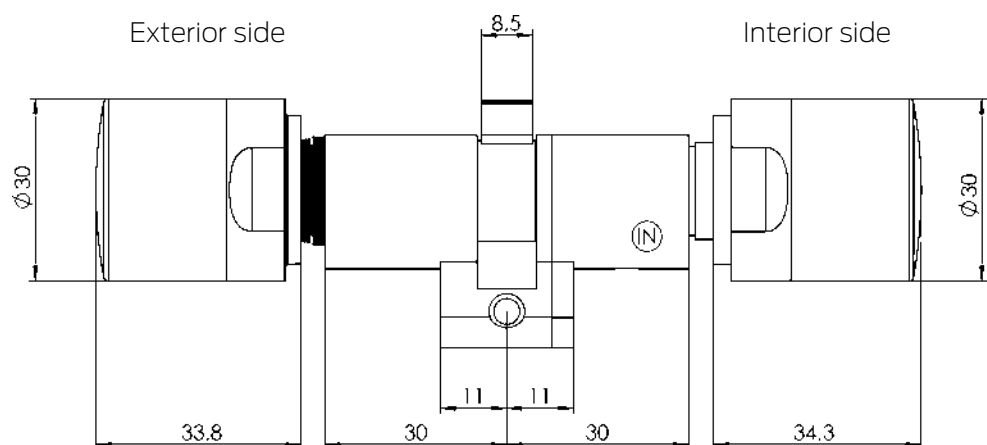

Swiss Round Comfort - Passive (SR CO MP)

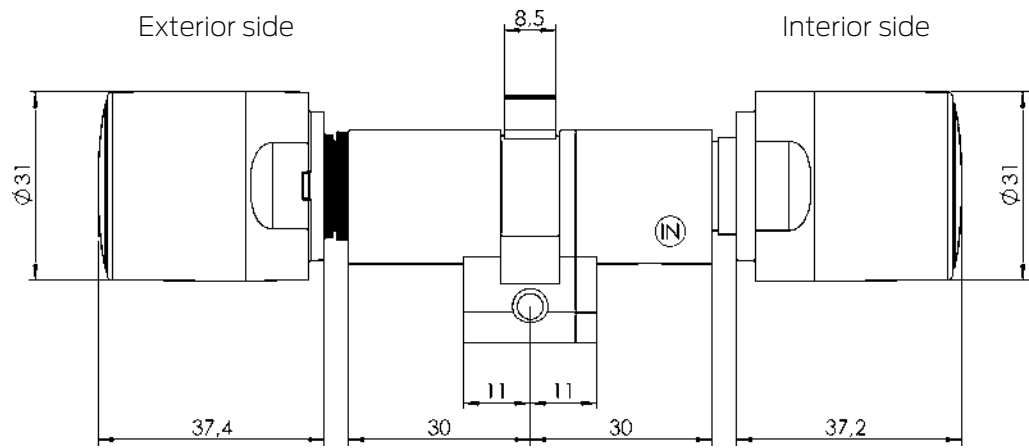

Swiss Round half cylinder - Active (SR HZ)

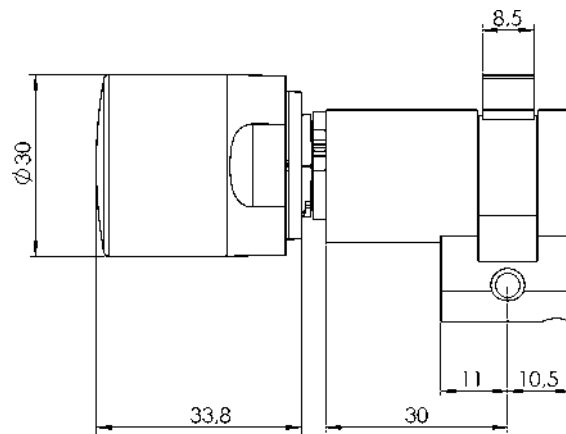

Swiss Round half cylinder - Passive (SR HZ MP)

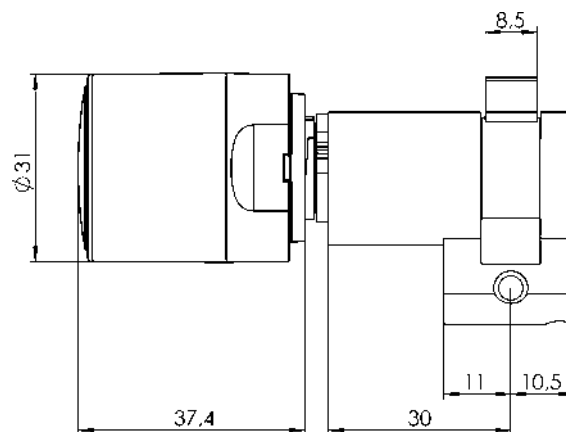

United Kingdom Mortise - Active (UKM)

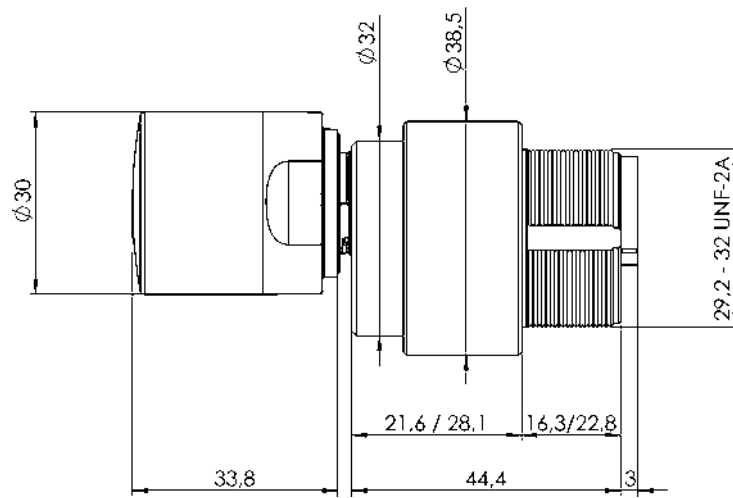

United Kingdom Mortise - Passive (UKM MP)

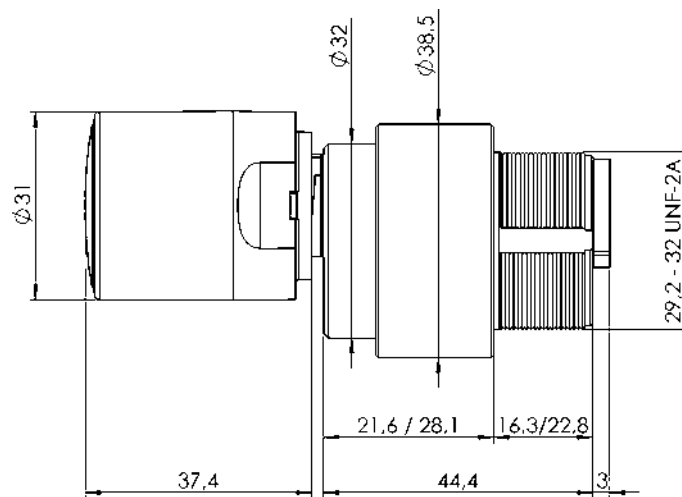

United Kingdom Outer Cylinder - Active (UKR)

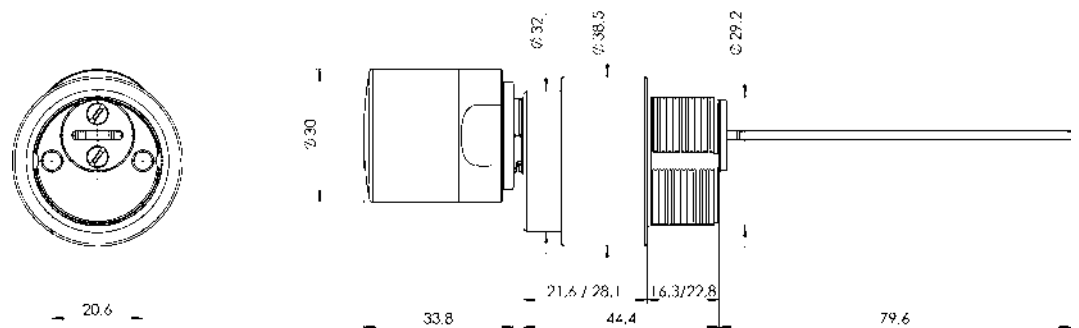

United Kingdom External Cylinder - Passive (UKR MP)

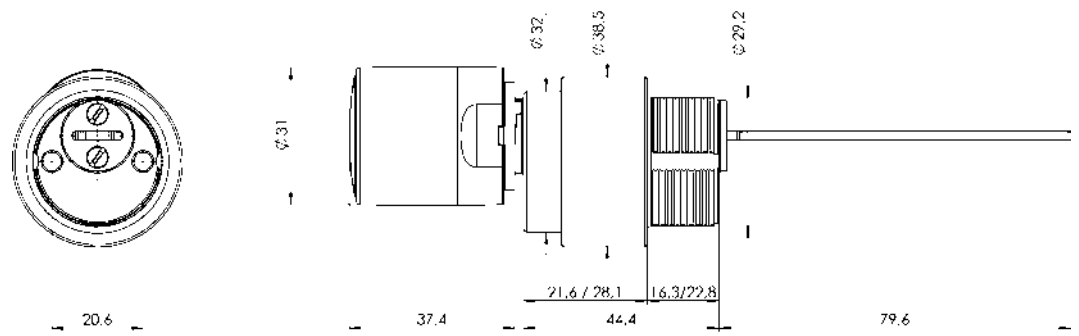

13. Declaration of conformity

The company SimonsVoss Technologies GmbH hereby declares that the articles (Z4.*, Z4.*MH*, Z4.*MP*) comply with the following guidelines:

- 2014/53/EU -RED-
or for the UK: UK statutory 2017 No. 1206 -Radio equipment-
- 2011/65/EU -RoHS-
or for the UK: UK statutory 2012 No. 3032 -RoHS-



The full text of the EU Declaration of conformity is available at the following internet address: www.simons-voss.com/en/certificates.html.

The full text of the UK Declaration of conformity is available at the following internet address: www.simons-voss.com/en/certificates.html.

14. Help and other information

Information material/documents

You will find detailed information on operation and configuration and other documents on the website:

<https://www.simons-voss.com/en/documents.html>

Declarations of conformity

You will find declarations of conformity and other certificates on the website:

<https://www.simons-voss.com/en/certificates.html>

Information on disposal

- Do not dispose the device (Z4.*, Z4.*MH*, Z4.*MP*) in the household waste. Dispose of it at a collection point for electronic waste as per European Directive 2012/19/EU.
- Recycle defective or used batteries in line with European Directive 2006/66/EC.
- Observe local regulations on separate disposal of batteries.
- Take the packaging to an environmentally responsible recycling point.



Technical support

Our technical support will be happy to help you (landline, costs depend on provider):

+49 (0) 89 / 99 228 333

Email

You may prefer to send us an email.

support-simonsvoss@allegion.com

FAQs

You will find information and help in the FAQ section:

<https://faq.simons-voss.com/otrs/public.pl>

Address

SimonsVoss Technologies GmbH
Feringastr. 4
D-85774 Unterfoehring
Germany



This is SimonsVoss

SimonsVoss, the pioneer in remote-controlled, cable-free locking technology provides system solutions with a wide range of products for SOHOs, SMEs, major companies and public institutions. SimonsVoss locking systems combine intelligent functionality, high quality and award-winning design Made in Germany.

As an innovative system provider, SimonsVoss focuses on scalable systems, high security, reliable components, powerful software and simple operation. As such, SimonsVoss is regarded as a technology leader in digital locking systems.

Our commercial success lies in the courage to innovate, sustainable thinking and action, and heartfelt appreciation of employees and partners.

SimonsVoss is a company in the ALLEGION Group, a globally active network in the security sector. Allegion is represented in around 130 countries worldwide (www.allegion.com).

Made in Germany

SimonsVoss is truly committed to Germany as a manufacturing location: all products are developed and produced exclusively in Germany.

© 2024, SimonsVoss Technologies GmbH, Unterföhring

All rights are reserved. Text, images and diagrams are protected under copyright law.

The content of this document must not be copied, distributed or modified. More information about this product can be found on the SimonsVoss website. Subject to technical changes.

SimonsVoss and MobileKey are registered brands belonging to SimonsVoss Technologies GmbH.

SimonsVoss
technologies

Made in Germany

A BRAND OF

ALLEGION™