

30  
60



Simons  Voss

DE Kurzanleitung  
EN Quick Guide  
FR Guide abrégé  
NL Korte handleiding  
IT Guida breve  
DK Kort vejledning  
SE Snabbguide

BS21.990606  
08.03.2024



**Digital SmartHandle AX**  
**Reader on both sides**

**Simons  Voss**  
technologies

Simons  Voss

Abbildungen/Images .....	3
deutsch .....	25
english .....	30
français .....	34
nederlands .....	39
italiano .....	43
dansk .....	48
svensk .....	52

### 5. Design

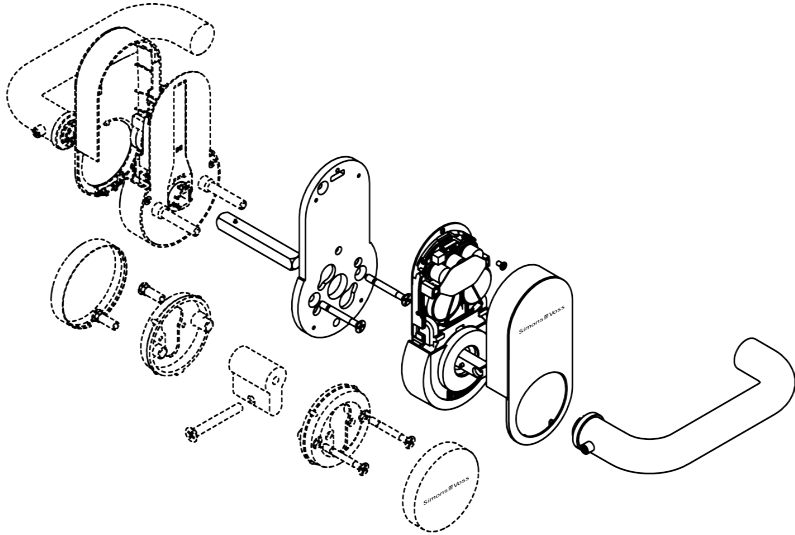

### 6. Prepare door (drilling template)



PH2

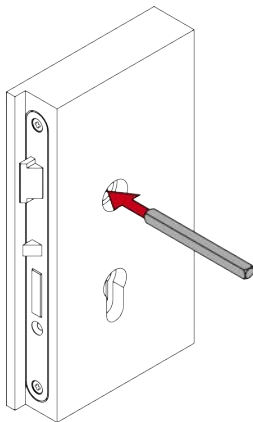

 3

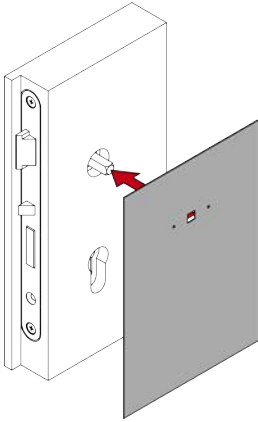

 4

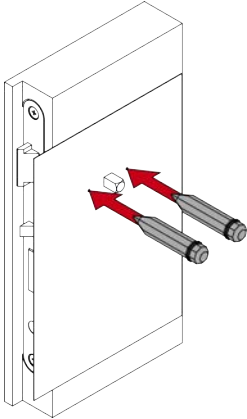

 5

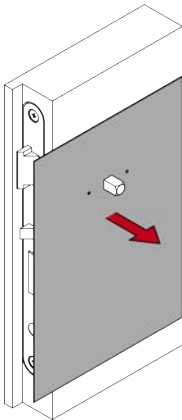

6

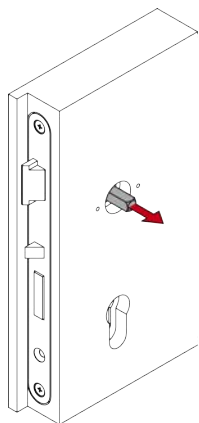

7



PH2

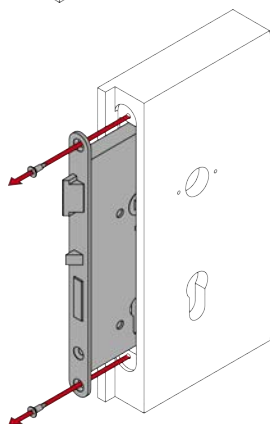

8

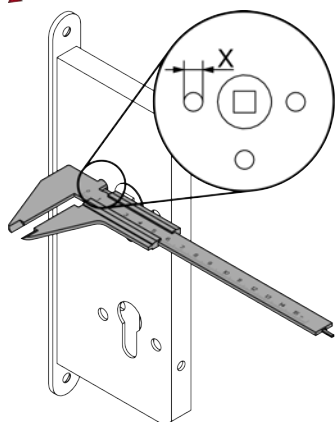

∅ fastening holes	Drill bits required
5.5 mm–6.3 mm	8.5 mm
6.4 mm–7.3 mm	8.5 mm
7.4 mm–8.7 mm	9.5 mm
≥ 8.8 mm	10.5 mm

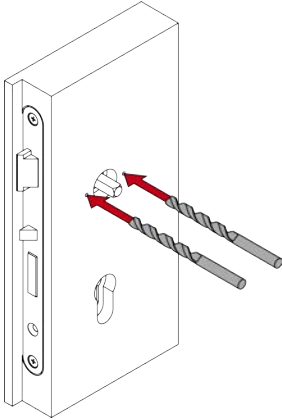

PH2

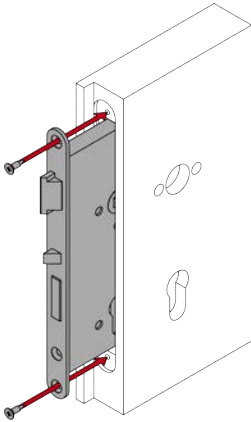

### 7. For door thickness X: prepare threaded rods and spindle



PH2

11

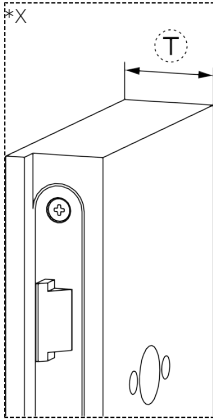

12



PH2

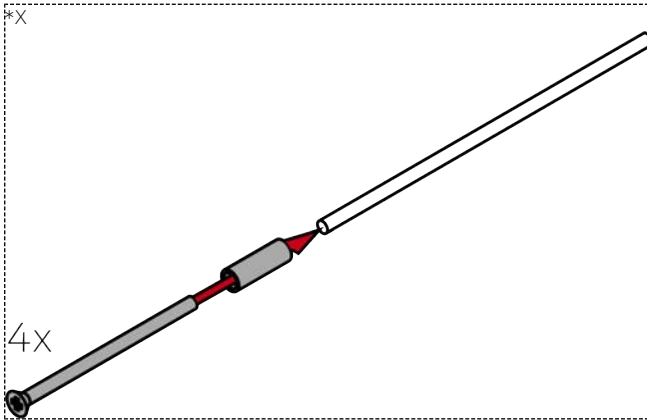

13

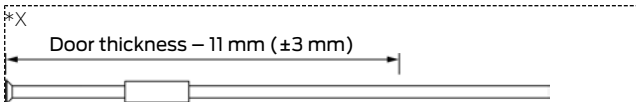

14

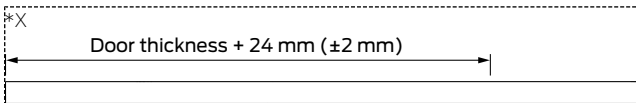

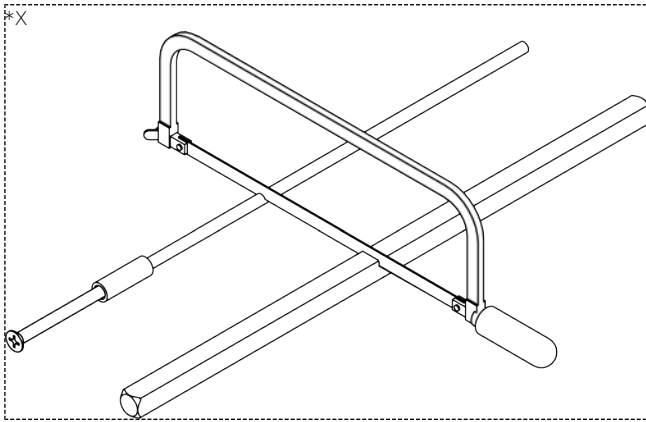

### 8. Programming the fitting

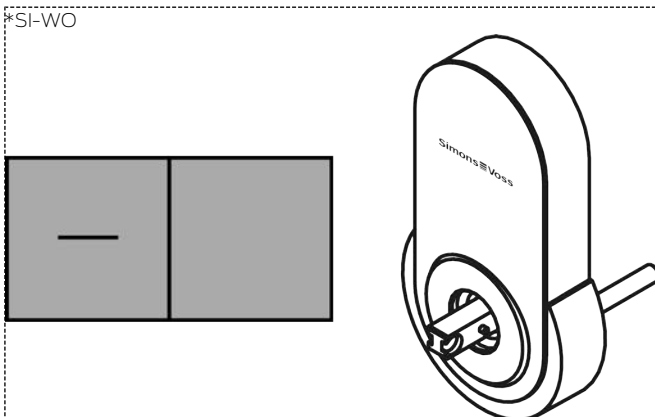
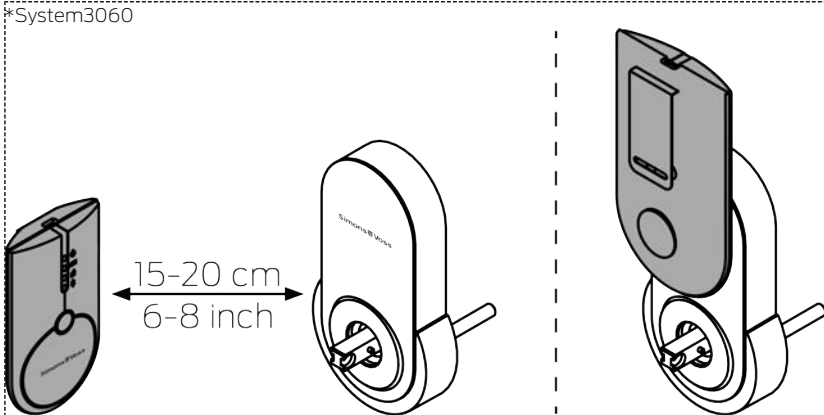



18

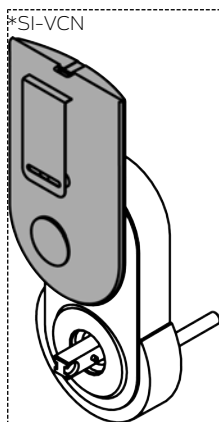

9. Installing the fitting

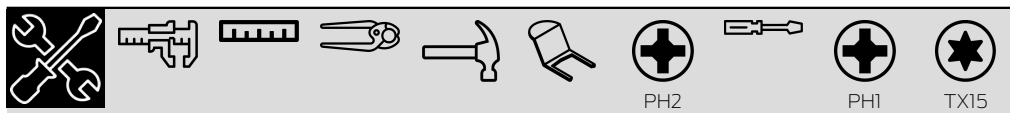

19

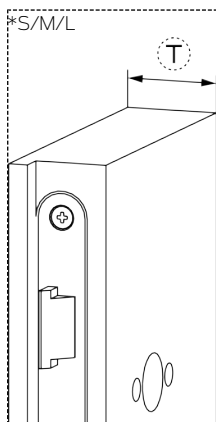

20

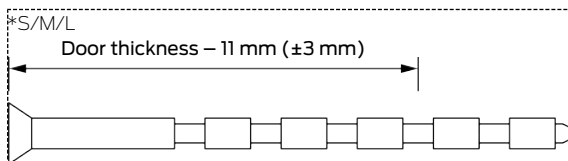

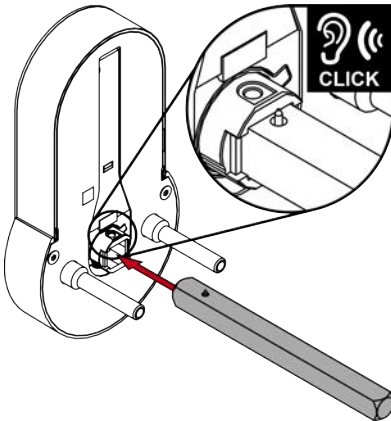
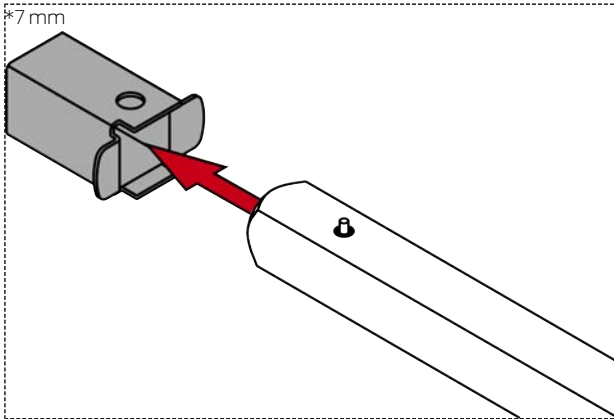
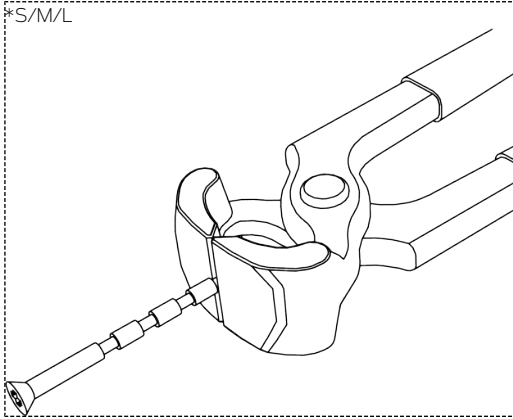

 24

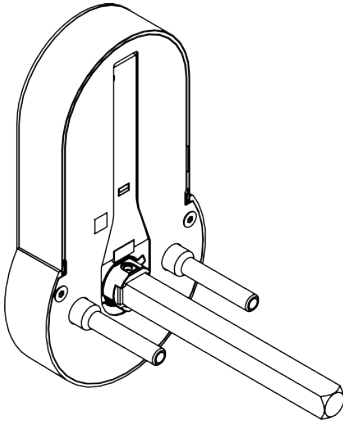

 25

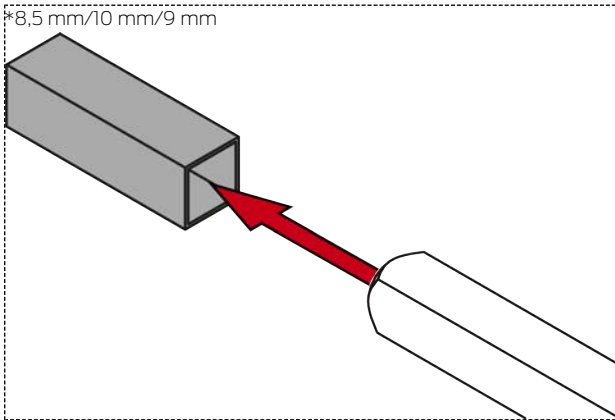

 26

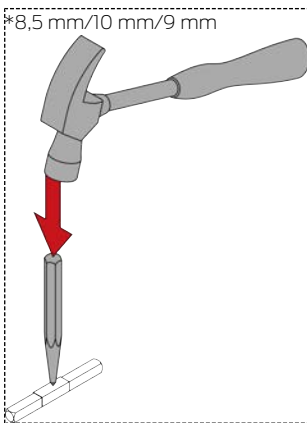

 27

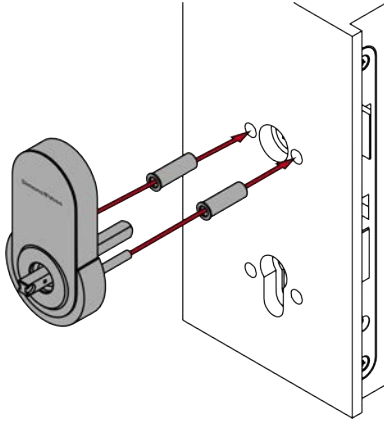

Ø mortise lock fastening hole	Adapter sleeves
5.5 mm–6.3 mm	No adapter sleeves
6.4 mm–7.3 mm	6.4 mm
7.4 mm–8.7 mm	7.4 mm
≥ 8.8 mm	8.8 mm

 28

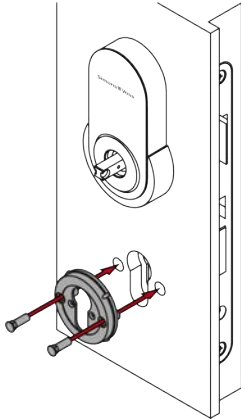

29

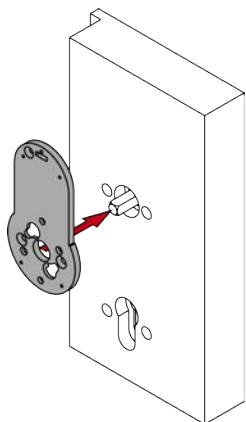

30

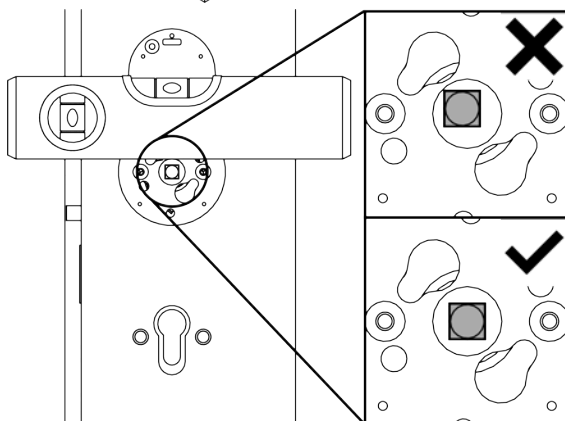

31



PH2



1,1 Nm  
±10%

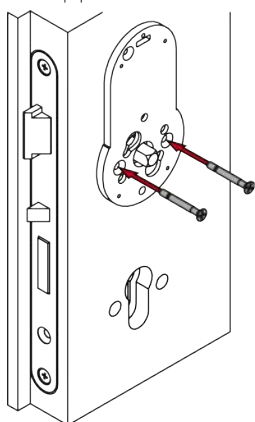

 32



PH2



1.1 Nm  
±10%

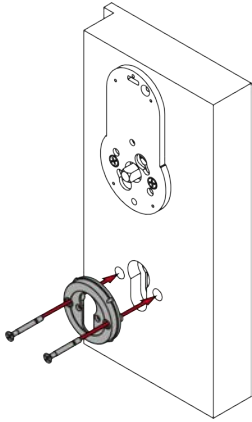

 33

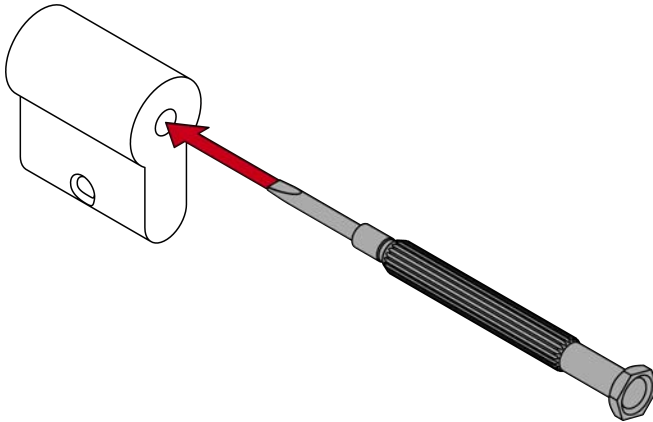

 34

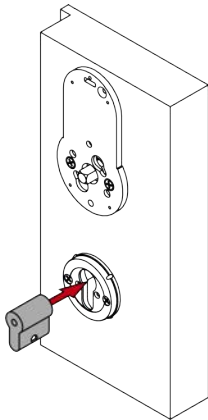

 35



PH2



1.1 Nm  
±10%

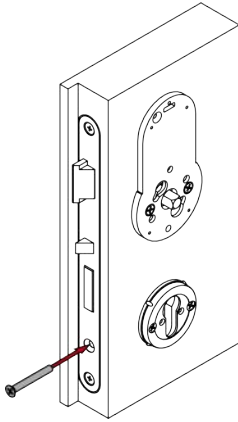

 36

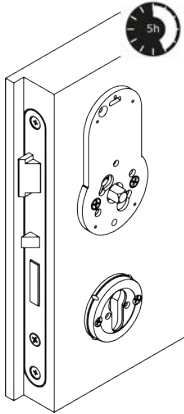

 37

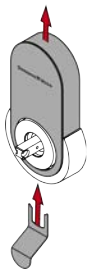

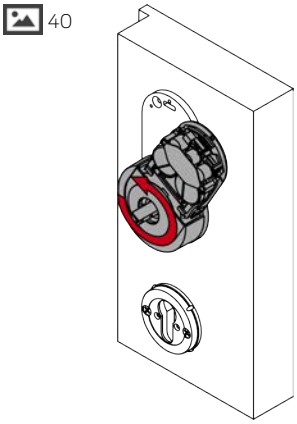
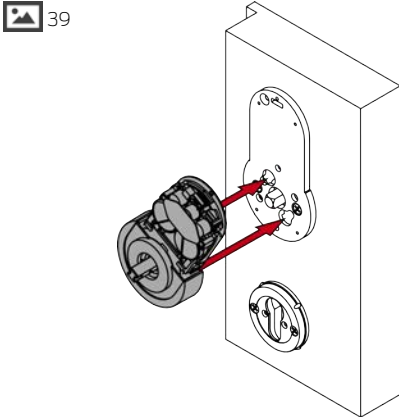
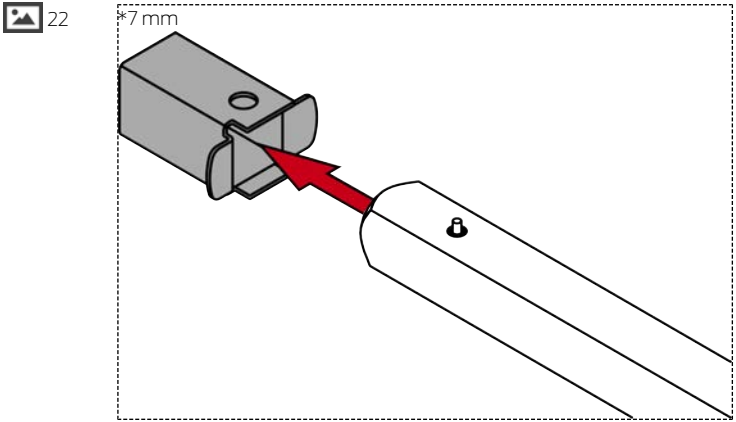



41



PH1



0.8 Nm  
±10%

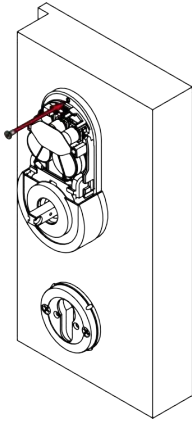

42

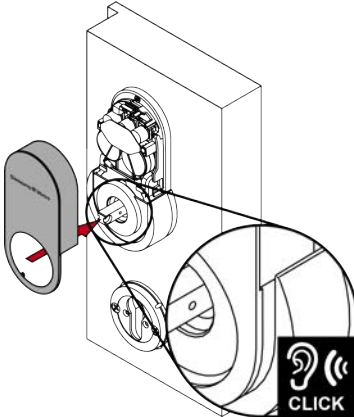

43

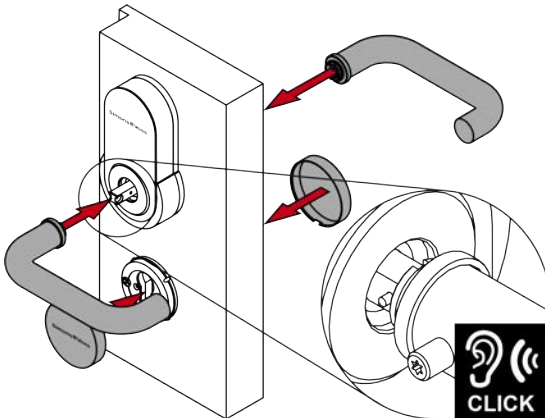



TX15



5.0 Nm  
±20%

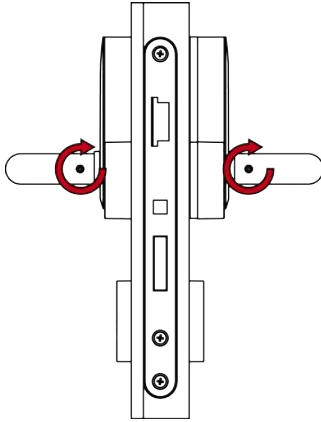

### 10. Removing the fitting



SW1.5



SW1.5

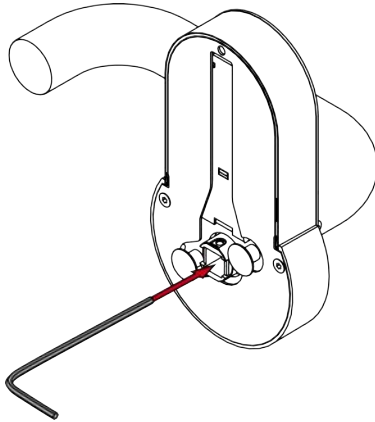

46



SW1.5

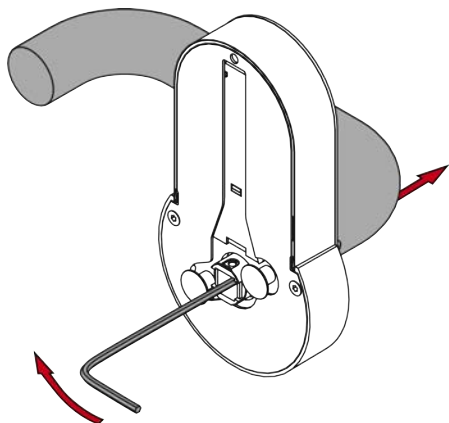

### 11. Replacing the batteries



47

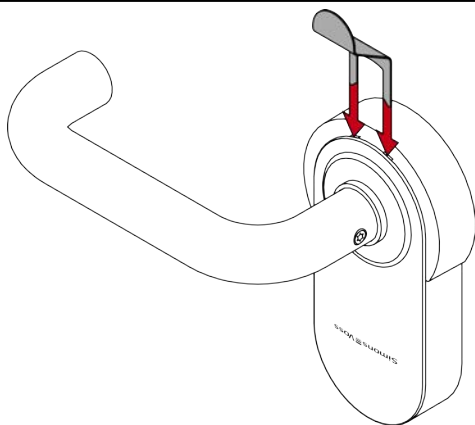

 48

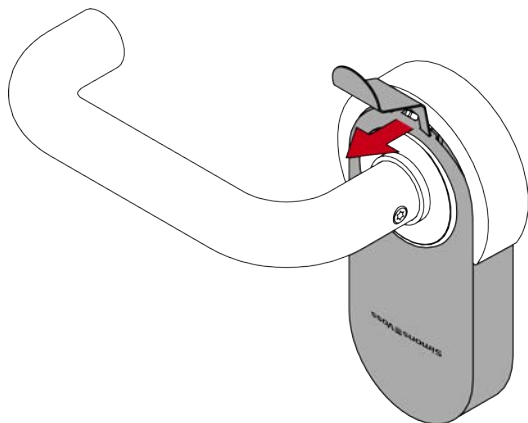

 49

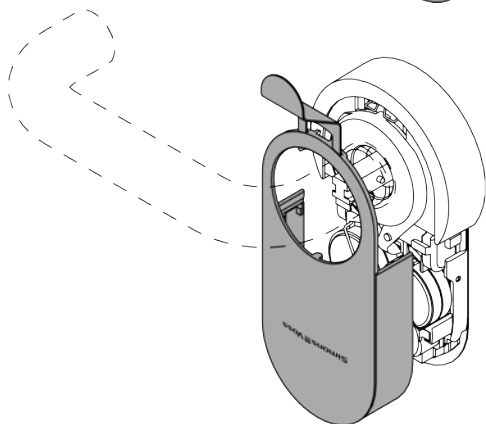

 50

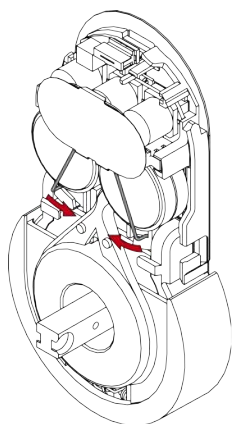

 51

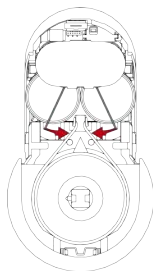

 52

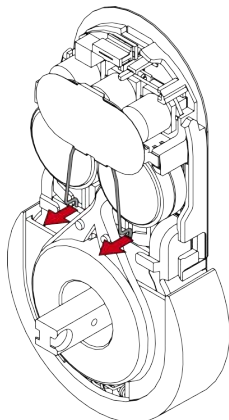

 53

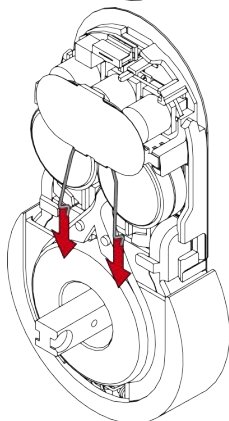

 54

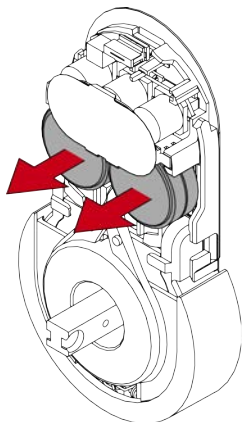

 55

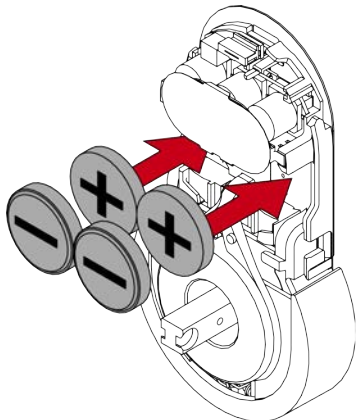

 56

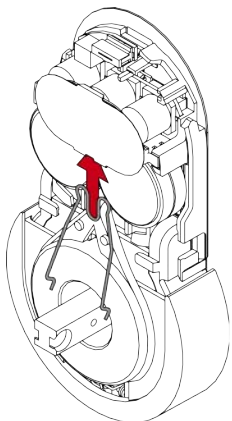

 57

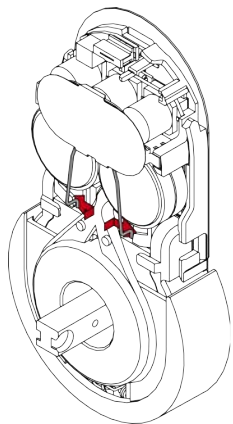

 58

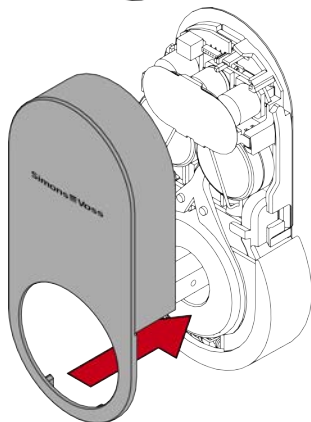

 59

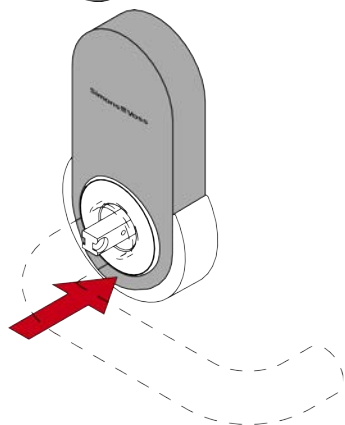

## 14. Help and other information



60





## 1. Bestimmungsgemäßer Gebrauch

Bei den Produkten der SmartHandle AX-Serie handelt es sich um elektronische Türbeschläge. Mithilfe eines berechtigten Identifikationsmediums kann das SmartHandle AX einkuppeln und die entsprechende Tür öffnen.

Entsprechende Berechtigungen müssen mit Hilfe eines elektronischen Schließplans erteilt werden.

Produkte der SmartHandle AX-Serie dürfen nur für das Öffnen und Schließen von Türen genutzt werden. Ein anderer Gebrauch ist nicht zulässig.

## 2. Allgemeine Sicherheitshinweise

*Signalwort: Mögliche unmittelbare Auswirkungen bei Nichtbeachtung*

**WARNUNG:** Tod oder schwere Verletzung (möglich, aber unwahrscheinlich), **VORSICHT:** Leichte Verletzung, **ACHTUNG:** Sachschäden oder Fehlfunktionen, **HINWEIS:** Geringe oder keine



### WARNUNG

#### Versperrter Zugang

Durch fehlerhaft montierte und/oder programmierte Komponenten kann der Zutritt durch eine Tür versperrt bleiben. Für Folgen eines versperrten Zutritts wie Zugang zu verletzten oder gefährdeten Personen, Sachschäden oder anderen Schäden haftet die SimonsVoss Technologies GmbH nicht!

#### Versperrter Zugang durch Manipulation des Produkts

Wenn Sie das Produkt eigenmächtig verändern, dann können Fehlfunktionen auftreten und der Zugang durch eine Tür versperrt werden.

- Verändern Sie das Produkt nur bei Bedarf und nur in der Dokumentation beschriebenen Art und Weise.

#### Batterie nicht einnehmen. Verbrennungsgefahr durch gefährliche Stoffe

Dieses Produkt enthält Lithium-Knopfzellen. Wenn die Knopfzelle verschluckt wird, können schwere innere Verbrennungen innerhalb von gerade einmal zwei Stunden auftreten und zum Tode führen.

1. Halten Sie neue und gebrauchte Batterien von Kindern fern.
2. Wenn das Batteriefach nicht sicher schließt, dann benutzen Sie das Produkt nicht mehr und halten Sie es von Kindern fern.
3. Wenn Sie meinen, dass Batterien verschluckt wurden oder sich in irgendeinem Körperteil befinden, suchen Sie unverzüglich medizinische Hilfe auf.

#### Explosionsgefahr durch falschen Batterietyp

Das Einsetzen falscher Batterietypen kann zu einer Explosion führen.

- Verwenden Sie ausschließlich die in den technischen Daten spezifizierten Batterien.



### VORSICHT

#### Feuergefahr durch Batterien

Die eingesetzten Batterien können bei Fehlbehandlung eine Feuer- oder Verbrennungsgefahr darstellen.

1. Versuchen Sie nicht, die Batterien aufzuladen, zu öffnen, zu erhitzen oder zu verbrennen.
2. Schließen Sie die Batterien nicht kurz.

### ACHTUNG

#### Beschädigung durch elektrostatische Entladung (ESD) bei geöffnetem Gehäuse

Dieses Produkt enthält elektronische Bauteile, die durch elektrostatische Entladungen beschädigt werden können.

1. Verwenden Sie ESD-gerechte Arbeitsmaterialien (z.B. Erdungsarmband).
2. Erden Sie sich vor Arbeiten, bei denen Sie mit der Elektronik in Kontakt kommen könnten. Fassen Sie dazu geerdete metallische Oberflächen an (z.B. Türgargen, Wasserrohre oder Heizungsventile).

#### Beschädigung durch Öle, Fette, Farben und Säuren

Dieses Produkt enthält elektronische und/oder mechanische Bauteile, die durch Flüssigkeiten aller Art beschädigt werden können.

- Halten Sie Öle, Fette, Farben und Säuren vom Produkt fern.

#### Beschädigung durch aggressive Reinigungsmittel

Die Oberfläche dieses Produkts kann durch ungeeignete Reinigungsmittel beschädigt werden.

- Verwenden Sie ausschließlich Reinigungsmittel, die für Kunststoff- bzw. Metalloberflächen geeignet sind.

#### Beschädigung durch mechanische Einwirkung

Dieses Produkt enthält elektronische Bauteile, die durch mechanische Einwirkung aller Art beschädigt werden können.

1. Vermeiden Sie das Anfassen der Elektronik.
2. Vermeiden Sie sonstige mechanische Einwirkungen auf die Elektronik.

#### Beschädigung durch Verpolung

Dieses Produkt enthält elektronische Bauteile, die durch die Verpolung der Spannungsquelle beschädigt werden können.

- Verpolen Sie die Spannungsquelle nicht (Batterien bzw. Netzteile).

#### Störung des Betriebs durch Funkstörung

Dieses Produkt kann unter Umständen durch elektromagnetische oder magnetische Störungen beeinflusst werden.

- Montieren bzw. platzieren Sie das Produkt nicht unmittelbar neben Geräten, die elektromagnetische oder magnetische Störungen verursachen können (Schaltnetzteile).

#### Störung der Kommunikation durch metallische Oberflächen

Dieses Produkt kommuniziert drahtlos. Metallische Oberflächen können die Reichweite des Produkts erheblich reduzieren.

- Montieren bzw. platzieren Sie das Produkt nicht auf oder in der Nähe von metallischen Oberflächen.



### HINWEIS

#### Bestimmungsgemäßer Gebrauch

SimonsVoss-Produkte sind ausschließlich für das Öffnen und Schließen von Türen und vergleichbaren Gegenständen bestimmt.

- Verwenden Sie SimonsVoss-Produkte nicht für andere Zwecke.

#### Funktionsstörungen durch schlechten Kontakt oder unterschiedliche Entladung

Zu kleine/verunreinigte Kontaktflächen oder unterschiedliche entladene Batterien können zu Funktionsstörungen führen.

1. Verwenden Sie nur Batterien, die von SimonsVoss freigegeben sind.
2. Berühren Sie die Kontakte der neuen Batterien nicht mit den Händen.
3. Verwenden Sie saubere und fettfreie Handschuhe.
4. Tauschen Sie immer alle Batterien gleichzeitig aus.

#### Abweichende Zeiten bei G2-Schließungen

Die interne Zeiteinheit der G2-Schließungen hat eine technisch bedingte Toleranz von bis zu  $\pm 15$  Minuten pro Jahr.

#### Qualifikationen erforderlich

Die Installation und Inbetriebnahme setzt Fachkenntnisse voraus.

- Nur geschultes Fachpersonal darf das Produkt installieren und in Betrieb nehmen.

Änderungen bzw. technische Weiterentwicklungen können nicht ausgeschlossen und ohne Ankündigung umgesetzt werden.

Die deutsche Sprachfassung ist die Originalbetriebsanleitung. Andere Sprachen (Abfassung in der Vertragssprache) sind Übersetzungen der Originalbetriebsanleitung.

Lesen Sie alle Anweisungen zur Installation, zum Einbau und zur Inbetriebnahme und befolgen Sie diese. Geben Sie diese Anweisungen und jegliche Anweisungen zur Wartung an den Benutzer weiter.

## 3. Produktspezifische Sicherheitshinweise

### ACHTUNG

#### Beschädigung durch Bohren

Sie bohren auf eigene Gefahr. Für Schäden, die durch das Bohren entstanden sind, haftet die SimonsVoss Technologies GmbH nicht.

- Beachten Sie auch die Sicherheitshinweise der Bohrmaschine.

#### Beschädigung durch ungeeignetes Werkzeug

Wenn Sie versuchen, das Gehäuse mit ungeeignetem Werkzeug zu öffnen, dann kann das Gehäuse beschädigt werden.

- Verwenden Sie nur das mitgelieferte SimonsVoss-Öffnungswerkzeug.

#### Verlust der präzisen Führung des Drückers

Die Montage kann bei Einsteckschlössern mit Klemmnuss schwergängig sein.

- Bearbeiten Sie die Klemmnuss nicht mechanisch. Der Drücker verliert dabei seine passgenaue Führung.

#### Erschwerte Montage durch ungenaue Bohrungen

Der Beschlag ist nicht montierbar, wenn die Befestigungsbohrungen und der Vierkant nicht zueinander passen.

- Stellen Sie sicher, dass die Linien der Befestigungsbohrungen und des Vierkants vertikal parallel sind.



### HINWEIS

#### Aktiv- und Hybrid-Technologie nur mit verkürzter Reichweite

Die Aktiv- und Hybrid-Technologien haben eine deutlich größere Reichweite. Im Normalbetrieb werden beide SmartHandle AX gleichzeitig erreicht und es kann zu Kommunikationsfehlern kommen.

- Aktivieren Sie in der LSM/AXM für beide Seiten am SmartHandle AX die Checkbox zur verkürzten Reichweite.

#### Wirkung auf das Einsteckschloss

Das SmartHandle AX wirkt ausschließlich auf die Falle des Einsteckschlössers.

#### Versicherungsrechtliches Verschließen

Versicherungen stellen erhöhte Anforderungen an eine Schließung.

- Wenn Sie die Tür versicherungsrechtlich verschließen wollen, dann verwenden Sie ein selbstverriegelndes Panikschloss (SVP) oder zusätzlich zum SmartHandle AX einen Schließzylinder.
- Achten Sie auf die Zulassungen nach EN 179.

#### SmartHandle mit selbstverriegelndem Panikschloss

Das SmartHandle AX bietet nur mit einem selbstverriegelndem Panikschloss die volle Funktionalität.

- Kombinieren Sie das SmartHandle AX mit einem selbstverriegelndem Panikschloss (SVP).
- Achten Sie auf die Konformitätserklärungen der Schlosshersteller nach EN 179.

#### Auflagen zur Berechtigungssicherheit

Der Betrieb mit Mifare Classic und/oder PinCode-Tastatur schließt die Berechtigungssicherheit Klasse D nach DIN EN 16867:2020 aus.

#### Verschluss der Rosettenöffnung

Eine ggfs. vorhandene Rosettenöffnung kann für Manipulationen genutzt werden.

- Verschließen Sie ggfs. vorhandene Rosettenöffnungen, zum Beispiel mit einem Blindzylinder.
- Bei FH-Varianten: Bauen Sie zwingend einen Blind- oder Schließzylinder aus Messing ein.

#### Ruhezeit für rutschhemmende Auflage

Die mitgelieferte Adapterplatte ist mit einer rutschhemmenden Auflage ausgestattet. Diese benötigt eine Setzzeit, um vollständig zu wirken.

- Warten Sie nach der Montage der Adapterplatte fünf Stunden, bevor Sie mit der Montage fortfahren.
- Falls Sie vorher fertigmontieren müssen: Betätigen Sie den Drücker nicht bis zum Anschlag.

## 4. Lieferumfang

- SmartHandle AX (für die beidseitige Montage, bestehend aus Adapterplatten und Innenteil. Das stehende SmartHandle AX für den Außenteil ist nicht enthalten.)

- Spezialwerkzeug

- Kurzanleitung

Je nach Variante:

- Adaptersatz 7-mm-Vierkant
- Adapterhülse 8,5-mm-Vierkant
- Adapterhülse 9-mm-Vierkant
- Adapterhülse 10-mm-Vierkant

## 5. Aufbau



## 6. Tür vorbereiten (Bohrschablone)

- ✓ Stift oder Anreißnadel vorhanden.
- ✓ Bohrmaschine vorhanden.
- ✓ Geeigneter Bohrer vorhanden (abhängig vom Einsteckschloss-Lochdurchmesser: 8,5 mm / 9,5 mm / 10,5 mm).
- ✓ PH2-Schraubendreher vorhanden.

- Stecken Sie den Vierkant in das Einsteckschloss.



- Stecken Sie die Bohrschablone auf den Vierkant.



- Richten Sie die Bohrschablone mithilfe der aufgedruckten Skala senkrecht aus.

- Markieren Sie die zu bohrenden Punkte auf der Tür.



- Entfernen Sie die Bohrschablone.



- Entfernen Sie den Vierkant.



- Bauen Sie das Einsteckschloss aus (PH2).



- Messen Sie den Durchmesser der Befestigungslöcher.



Ø Befestigungslöcher	Benötigter Bohrer
5,5 mm - 6,3 mm	8,5 mm
6,4 mm - 7,3 mm	8,5 mm
7,4 mm - 8,7 mm	9,5 mm
≥ 8,8 mm	10,5 mm

- Bestimmen Sie mit dem gemessenen Durchmesser den benötigten Bohrer.

- Bohren Sie die benötigten Löcher.



- Bauen Sie das Einsteckschloss ein (PH2).



## 7. Für Türdicke X: Gewindestangen und Vierkant vorbereiten

- ✓ Säge vorhanden.
- ✓ Messschieber vorhanden.
- ✓ PH2-Schraubendreher vorhanden.

1. Für X: Messen Sie die Türdicke.



2. Für X: Schrauben Sie die Schrauben, die Gewindehülsen und die Gewindestangen zusammen.



3. Für X: Markieren Sie die Sägestellen an den Gewindestangen und am Vierkant.



4. Für X: Kürzen Sie mit einer geeigneten Säge die Gewindestangen und den Vierkant.



## 8. Beschlag programmieren

Programmieren Sie den Beschlag vor der Montage. Je nach Produktfamilie können Sie verschiedene Programmiergeräte verwenden.



## 9. Beschlag montieren

- ✓ Tür vorgebohrt.
- ✓ PH2-Schraubendreher vorhanden.
- ✓ TX15-Schraubendreher vorhanden.
- ✓ Messschieber vorhanden.
- ✓ Kneifzange vorhanden.

1. Für S, M und L: Messen Sie die Türdicke.



2. Für S, M und L: Bestimmen Sie die Trennstellen an den Absatzschrauben.



3. Für S, M und L: Kürzen Sie die Absatzschrauben.



4. Für 7-mm-Vierkant: Stecken Sie die Adapterhülse auf die Seite des Vierkants mit Pin.



5. Stecken Sie den Vierkant mit der Pin-Seite in den Beschlag.

- ↳ Pin schnappt in die Aufnahme ein.



6. Für 8,5-mm-, 9-mm- und 10-mm-Vierkant: Schieben Sie die Adapterhülse in die Mitte des Vierkants. Machen Sie mit Körner und Hammer eine Vertiefung in die Adapterhülse, um das Verrutschen zu verhindern.



7. Stecken Sie den Außen-Beschlag, ggfs. mit Adapterhülsen, von der Außenseite in die Tür.



Ø Einsteckschloss-Befestigungsloch	Adapterhülsen
5,5 mm - 6,3 mm	keine Adapterhülsen
6,4 mm - 7,3 mm	6,4 mm
7,4 mm - 8,7 mm	7,4 mm
≥ 8,8 mm	8,8 mm

8. Stecken Sie die Rosettenbasis mit den Hülsenmuttern auf der Außenseite in die Tür.



9. Legen Sie die Adapterplatte an die Tür an.



10. Richten Sie die Adapterplatte so aus, dass der Vierkant exakt mittig und die Adapterplatte exakt senkrecht ist.



11. Schrauben Sie die Adapterplatte fest (PH2, Drehmoment: 1,1 Nm).



12. Schrauben Sie die Rosettenbasis auf der Innenseite fest.



13. Setzen Sie den Blindzylinder ein.



### HINWEIS

#### Blindzylinder mit Schraubendreher im Loch führen

Insbesondere bei dicken Türen ist es schwierig, den Blindzylinder richtig zu positionieren.

1. Stecken Sie einen Schraubendreher in das Loch des Blindzylinders.
2. Positionieren Sie den Blindzylinder mithilfe des Schraubendrehers.



14. Schrauben Sie den Blindzylinder fest (PH2, Drehmoment: 1,1 Nm).



15. Warten Sie fünf Stunden, bis sich die Antirutschbeschichtung gesetzt hat.



### HINWEIS

#### Ruhezeit für rutschhemmende Auflage

Die mitgelieferte Adapterplatte ist mit einer rutschhemmenden Auflage ausgestattet. Diese benötigt eine Setzzeit, um vollständig zu wirken.

1. Warten Sie nach der Montage der Adapterplatte fünf Stunden, bevor Sie mit der Montage fortfahren.
2. Falls Sie vorher fertigmontieren müssen: Betätigen Sie den Drücker nicht bis zum Anschlag.



16. Nehmen Sie das Cover mit dem Werkzeug ab.



17. Für 7-mm-Vierkant: Stecken Sie die Adapterhülse auf den Vierkant.



18. Stecken Sie den Beschlag in die Adapterplatte.



19. Drehen Sie den Beschlag gerade.



20. Schrauben Sie den Beschlag an der Adapterplatte fest, um das Verdrehen zu verhindern.



21. Stecken Sie das Cover auf den Beschlag.



22. Stecken Sie die Außendrücker auf die Beschläge.  
23. Stecken Sie die Blenden auf die Rosettenbasen.



24. Schrauben Sie die Madenschrauben beider Drücker fest (TX15, Drehmoment: 5,0 Nm).



- ↳ Beschlag ist fertig montiert.

## 10. Beschlag demontieren

- ✓ 1,5-mm-Sechskantschlüssel vorhanden.

1. Demontieren Sie den Beschlag in umgekehrter Reihenfolge zur Montage.  
2. Stecken Sie einen 1,5-mm-Sechskantschlüssel in das Loch der Vierkantaufnahme im Beschlag.



3. Biegen Sie den Sechskantschlüssel auf die Seite, auf der sich das Loch befindet und ziehen Sie gleichzeitig am Außendrücker.



- ↳ Beschlag ist demontiert.

## 11. Batterien wechseln



### HINWEIS

**Funktionsstörungen durch schlechten Kontakt oder unterschiedliche Entladung**

Zu kleine/verunreinigte Kontaktflächen oder unterschiedliche entladene Batterien können zu Funktionsstörungen führen.

- Verwenden Sie nur Batterien, die von SimonsVoss freigegeben sind.
- Berühren Sie die Kontakte der neuen Batterien nicht mit den Händen.
- Verwenden Sie saubere und fettfreie Handschuhe.
- Tauschen Sie immer alle Batterien gleichzeitig aus.

- ✓ Spezialwerkzeug ist vorhanden.  
✓ Handschuhe vorhanden.

1. Stecken Sie das Spezialwerkzeug in das Cover-Inlay des Beschlags.



2. Nehmen Sie das Cover mit dem Werkzeug ab.



3. Biegen Sie die Batterieklammer vorsichtig nach innen, um sie auszuheben.



4. Öffnen Sie die Batterieklammer.



5. Ziehen Sie die Batterieklammer heraus.



6. Entnehmen Sie die alten Batterien.



7. Setzen Sie die neuen Batterien mit sich berührenden Pluspolen ein (Typ CR2450).



8. Setzen Sie die Batterieklammer wieder ein.



9. Haken Sie die Batterie-Klammer wieder ein.



10. Stecken Sie das Cover wieder auf den Beschlag.



11. Klipsen Sie das Cover wieder fest.



- ↳ Batterien sind gewechselt.

## 12. Technische Daten

Temperaturbereich (Betrieb)	-25 °C bis +50 °C
Batterietyp	4× CR2450 (3V)
Batteriehersteller	<ul style="list-style-type: none"> <li>■ Murata</li> <li>■ Varta</li> <li>■ Panasonic</li> </ul>
IP-Schutzklasse	IP40

### Funkemissionen

15,24 kHz - 72,03 kHz Nur für Artikelnummern: SV-S2.*A*, SV-S2.*AM*, SV-S2.*LN*	10 dBµA/m (3 m Entfernung)
13,560006 MHz - 13,560780 MHz	1,04 dBµA/m (3 m Entfernung)
868,000 MHz - 868,600 MHz / 869,700 MHz - 870,000 MHz Nur für Artikelnummern: SV-S2.*LN*, SI-S2.*M.WO*	<25 mW ERP
2402 MHz - 2480 MHz	2,5 mW

## 13. Konformitätserklärung

Hiermit erklärt die SimonsVoss Technologies GmbH, dass die Artikel (SV-S2.\*A\*, SV-S2.\*AM\*, SV-S2.\*LN\*, SI-S2.\*M.WO\*, SI-S2.\*M.VCN\*) folgenden Richtlinien entsprechen:

- 2014/53/EU -Funkanlagen- bzw. für UK: Rechtsverordnung 2017 Nr. 1206 -Funkanlagen-
- 2011/65/EU -RoHS- bzw. für UK: Rechtsverordnung 2012 Nr. 3032 -RoHS-



Der vollständige Text der EU-Konformitätserklärung ist unter der folgenden Internetadresse verfügbar: [www.simons-voss.com/de/zertifikate.html](http://www.simons-voss.com/de/zertifikate.html).  
Der vollständige Text der UK-Konformitätserklärung ist unter der folgenden Internetadresse verfügbar: [www.simons-voss.com/de/zertifikate.html](http://www.simons-voss.com/de/zertifikate.html).

## 14. Hilfe und weitere Informationen

### Infomaterial/Dokumente

<https://www.simons-voss.com/de/dokumente.html>  
<https://www.smartintego.com/de/home/infocenter/dokumentation>

### Konformitätserklärungen und Zertifikate

<https://www.simons-voss.com/de/zertifikate.html>

### Informationen zur Entsorgung

- Entsorgen Sie das Gerät (SV-S2.\*A\*, SV-S2.\*AM\*, SV-S2.\*LN\*, SI-S2.\*M.WO\*, SI-S2.\*M.VCN\*) nicht mit dem Hausmüll, sondern gemäß der europäischen Richtlinie 2012/19/EU bei einer kommunalen Sammelstelle für Elektro-Sonderabfälle.
- Recyceln Sie defekte oder verbrauchte Batterien gemäß der europäischen Richtlinie 2006/66/EG.
- Beachten Sie örtliche Bestimmungen zur getrennten Entsorgung von Batterien.
- Führen Sie die Verpackung einer umweltgerechten Wiederverwertung zu.



## E-Mail

*support-simonsvoss@allegion.com*

*si-support-simonsvoss@allegion.com*

SimonsVoss Technologies GmbH, Feringastr. 4, D-85774 Unterfoehring,  
Deutschland

## 1. Intended use

Products in the SmartHandle AX range consist of electronic door fittings. Users can engage SmartHandle AX and open the door onto which it is fitted with an authorised ID medium, such as a transponder.

The corresponding authorisations need to be issued using an electronic locking plan.

Products in the SmartHandle AX range may only be used for locking and unlocking doors. No other use is permitted.

## 2. General safety instructions

*Signal word: Possible immediate effects of non-compliance*

WARNING: Death or serious injury (possible, but unlikely), CAUTION: Minor injury, IMPORTANT: Property damage or malfunction, NOTE: Low or none



### WARNING

#### Blocked access

Access through a door may stay blocked due to incorrectly fitted and/or incorrectly programmed components. SimonsVoss Technologies GmbH is not liable for the consequences of blocked access such as access to injured or endangered persons, material damage or other damage!

#### Blocked access through manipulation of the product

If you change the product on your own, malfunctions can occur and access through a door can be blocked.

- Modify the product only when needed and only in the manner described in the documentation.

#### Do not swallow battery. Danger of burns from hazardous substances

This product contains lithium button cell batteries. Swallowing the button cell battery, in can result in severe internal burns leading to death in as little as two hours.

1. Keep new and used batteries away from children.
2. If the battery compartment does not close securely, cease using the product and keep it away from children.
3. If you think batteries have been swallowed or are in any part of the body, seek medical attention immediately.

#### Risk of explosion due to incorrect battery type

Inserting the wrong type of battery can cause an explosion.

- Only use the BATTERIES specified in the technical data.



### CAUTION

#### Fire hazard posed by batteries

The batteries used may pose a fire or burn hazard if handled incorrectly.

1. Do not try to charge, open, heat or burn the batteries.
2. Do not short-circuit the batteries.

### IMPORTANT

#### Damage resulting from electrostatic discharge (ESD) when enclosure is open

This product contains electronic components that may be damaged by electrostatic discharges.

1. Use ESD-compliant working materials (e.g. Grounding strap).
2. Ground yourself before carrying out any work that could bring you into contact with the electronics. For this purpose, touch earthed metallic surfaces (e.g. door frames, water pipes or heating valves).

#### Damage resulting from liquids

This product contains electronic and/or mechanic components that may be damaged by liquids of any kind.

- Keep liquids away from the electronics.

#### Damage resulting from aggressive cleaning agents

The surface of this product may be damaged as a result of the use of unsuitable cleaning agents.

- Only use cleaning agents that are suitable for plastic or metal surfaces.

#### Damage as a result of mechanical impact

This product contains electronic components that may be damaged by mechanical impacts of any kind.

1. Avoid touching the electronics.
2. Avoid other mechanical influences on the electronics.

#### Damage due to polarity reversal

This product contains electronic components that may be damaged by reverse polarity of the power source.

- Do not reverse the polarity of the voltage source (batteries or mains adapters).

#### Operational malfunction due to radio interference

This product may be affected by electromagnetic or magnetic interference.

- Do not mount or place the product directly next to devices that could cause electromagnetic or magnetic interference (switching power supplies!).

#### Communication interference due to metallic surfaces

This product communicates wirelessly. Metallic surfaces can greatly reduce the range of the product.

- Do not mount or place the product on or near metallic surfaces.



### NOTE

#### Intended use

SimonsVoss-products are designed exclusively for opening and closing doors and similar objects.

- Do not use SimonsVoss products for any other purposes.

#### Malfunctions due to poor contact or different discharge

Contact surfaces that are too small/contaminated or different discharged batteries can lead to malfunctions.

1. Only use batteries that are approved by SimonsVoss.
2. Do not touch the contacts of the new batteries with your hands.
3. Use clean and grease-free gloves.
4. Always replace all batteries at the same time.

#### Different times for G2 locks

The internal time unit of the G2 locks has a technical tolerance of up to  $\pm 15$  minutes per year.

#### Qualifications required

The installation and commissioning requires specialized knowledge.

- Only trained personnel may install and commission the product.

Modifications or further technical developments cannot be excluded and may be implemented without notice.

The German language version is the original instruction manual. Other languages (drafting in the contract language) are translations of the original instructions.

Read and follow all installation, installation, and commissioning instructions. Pass these instructions and any maintenance instructions to the user.

## 3. Product-specific safety instructions

### IMPORTANT

#### Damage by drilling

You drill at your own risk. SimonsVoss Technologies GmbH is not liable for damage caused by drilling.

- Please also observe the safety instructions of the drilling machine.

#### Damage caused by unsuitable tools

If you try to open the case with unsuitable tools, the case may be damaged.

- Use only the supplied SimonsVoss opening tool.

**Loss of the precise guidance of the handle**

It may be difficult to install on mortise locks with a retaining nut.

- Do not mechanically alter the locking nut. The handle would then lose its precise guidance.

**Difficult installation due to inaccurate holes**

The fitting cannot be installed if the fastening holes and the spindle do not match.

- Make sure that the fastening holes and the spindle are in parallel vertical lines.

**NOTE****Active and hybrid technology only with shortened range**

The active and hybrid technologies have a significantly greater range. Under normal operating conditions, both SmartHandle AX are reached at the same time and communication errors may occur.

- Activate the checkbox for a shortened range for both sides on the SmartHandle AX in LSM/AXM.

**Effect on the mortise lock**

The SmartHandle AX acts exclusively on the latch of the mortise lock.

**Locking and insurances**

Insurance companies place increased demands on a closure.

1. If you want to lock the door under insurance law, use a self-locking panic lock or a locking cylinder in addition to the SmartHandle AX.
2. Pay attention to the approvals according to EN 179.

**SmartHandle AX with self-locking panic lock**

The SmartHandle AX only offers full functionality with a self-locking panic lock.

1. Combine the SmartHandle AX with a self-locking panic lock.
2. Pay attention to the declarations of conformity of the lock manufacturers according to EN 179.

**Conditions for authorisation security**

Operation with Mifare Classic and/or PinCode keypad excludes authorisation security class D according to DIN EN 16867:2020.

**Sealing escutcheon holes**

Any escutcheon holes that exist may be used to manipulate the lock.

1. Seal any escutcheon holes with a blind cylinder, for example.
2. In the case of FH versions, you must be install a brass dummy cylinder or locking cylinder.

**Rest time for anti-slip surface**

The supplied adapter plate feature a non-slip surface. This requires a settling time for it to be fully effective.

1. After installing the adapter plate, wait five hours before continuing with the installation.
2. If you need to finish installing beforehand, do not turn the handle as far as it will go.

## 4. Scope of delivery

- SmartHandle AX (For installation on both sides, consisting of adapter plates and inner part. The stationary SmartHandle AX for the outer part is not included.)

- Special tool

- Quick guide

Depending on version:

- Adapter set, 7 mm spindle
- Adapter sleeve, 8.5 mm spindle
- Adapter sleeve, 9 mm spindle
- Adapter sleeve, 10 mm spindle

## 5. Design



## 6. Prepare door (drilling template)

- ✓ Pin or scriber at hand.
- ✓ Drill at hand.
- ✓ Suitable drill bit at hand (depending on mortise lock hole diameter: 8.5 mm/9.5 mm/10.5 mm).
- ✓ PH2 screwdriver at hand.

1. Insert the spindle into the mortise lock.



2. Place the drilling template on the spindle.



3. Align the drill template vertically using the printed scale.

4. Mark the points to be drilled on the door.



5. Remove the drilling template.



6. Remove the spindle.



7. Remove the mortise lock (PH2).



8. Measure the diameter of the fastening holes.



Ø fastening holes	Drill bits required
5.5 mm–6.3 mm	8.5 mm
6.4 mm–7.3 mm	8.5 mm
7.4 mm–8.7 mm	9.5 mm
≥ 8.8 mm	10.5 mm

9. Determine the required drill bit based on the measured diameter.
10. Drill the required holes.



11. Fit the mortise lock (PH2).



## 7. For door thickness X: prepare threaded rods and spindle

- ✓ Saw at hand.
- ✓ Vernier calliper at hand.
- ✓ PH2 screwdriver at hand.

1. For X: measure the door thickness.



2. For X: fasten the screws, threaded sleeves and threaded rods together.



3. For X: mark the sawing points on the threaded rods and spindle.



4. For X: use a suitable saw to cut the threaded rods and spindle.



## 8. Programming the fitting

Programme the fitting before installation. You can use different programming devices, depending on the product family.



16



17



18

## 9. Installing the fitting

- ✓ Door pre-drilled.
- ✓ PH2 screwdriver at hand.
- ✓ TX15 screwdriver at hand.
- ✓ Vernier calliper at hand.
- ✓ Pincers at hand.

1. For S, M and L: measure the door thickness.



19

2. For S, M and L: determine the cutting points on the cut-to-length screws.



20

3. For S, M and L: shorten the cut-to-length screws.



21

4. For 7 mm spindle: insert the adapter sleeve onto the side of the spindle with the pin.



22

5. Insert the spindle with the pin side into the fitting.



23

- ↳ Pin will snap into position in the mount.



24

6. For 8.5 mm, 9 mm and 10 mm spindles: slide the adapter sleeve into the centre of the spindle. Use a punch and hammer to make an indent in the adapter sleeve to prevent it from slipping.



25



26

7. Insert the outer fitting, with adapter sleeves if necessary, into the door from the outside.



27

Ø mortise lock fastening hole	Adapter sleeves
5.5 mm–6.3 mm	No adapter sleeves
6.4 mm–7.3 mm	6.4 mm
7.4 mm–8.7 mm	7.4 mm
≥ 8.8 mm	8.8 mm

8. Insert the escutcheon base into the door with the sleeve nuts on the outer side.



28

9. Position the adapter plate on the door.



29

10. Align the adapter plate so that the spindle is precisely centred and the adapter plate is perfectly perpendicular.



30

11. Screw the adapter plate firmly into place (PH2, torque 1.1 Nm).



31

12. Screw the escutcheon base into place on the inner side.



32

13. Insert the dummy cylinder.



### NOTE

#### Feed the blank cylinder into the hole using a screwdriver

It is difficult to position the blank cylinder correctly, especially in thick doors.

1. Insert a screwdriver into the hole in the blank cylinder.
2. Position the blank cylinder using the screwdriver.



33



34

14. Screw the dummy cylinder firmly into place (PH2, torque 1.1 Nm).



35

15. Wait five hours for the anti-slip coating to set.



### NOTE

#### Rest time for anti-slip surface

The supplied adapter plate feature a non-slip surface. This requires a settling time for it to be fully effective.

1. After installing the adapter plate, wait five hours before continuing with the installation.
2. If you need to finish installing beforehand, do not turn the handle as far as it will go.



36

16. Remove the cover with the tool.



37

17. For 7 mm spindle: attach the adapter sleeve to the spindle.



22

18. Insert the fitting into the adapter plate.



39

19. Rotate the fitting until it is straight.



40

20. Screw the fitting firmly onto the adapter plate to prevent it from twisting.



41

21. Place the cover on the fitting.



42

22. Place the outside handles on the fittings.

23. Place the covers on the escutcheon bases.



43

24. Fasten the grub screws firmly onto both handles (TX15, torque 5.0 Nm).



44

- ↳ Fitting is now installed.

## 10. Removing the fitting

- ✓ 1.5 mm hexagonal wrench available.

1. Remove the fitting in the reverse order to installation.
2. Insert a 1.5 mm hex key into the hole in the spindle mount in the fitting.



45

3. Bend the hex key to the side where the hole is located while pulling on the outside handle.



46

- ↳ Fitting is now removed.



## 11. Replacing the batteries



### NOTE

#### Malfunctions due to poor contact or different discharge

Contact surfaces that are too small/contaminated or different discharged batteries can lead to malfunctions.

1. Only use batteries that are approved by SimonsVoss.
2. Do not touch the contacts of the new batteries with your hands.
3. Use clean and grease-free gloves.
4. Always replace all batteries at the same time.

- ✓ Special tool at hand.
- ✓ Gloves at hand.

1. Insert the special tool into the fitting's cover inlay.



2. Remove the cover with the tool.



3. Carefully bend the battery clip inwards to detach it.



4. Open the battery holder.



5. Remove the battery holder.



6. Remove the old batteries.



7. Insert the new batteries with the positive terminals next to each other (type CR2450).



8. Put the battery holder back into place.



9. Reattach the battery clip.



10. Replace the cover on the fitting.



11. Snap the cover back into place.



- ↳ Batteries are now replaced.

## 12. Technical data

Operating temperature range	-25 °C to +50 °C
Battery type	4x CR2450 (3V)
Battery manufacturer	<ul style="list-style-type: none"> <li>■ Murata</li> <li>■ Varta</li> <li>■ Panasonic</li> </ul>
IP protection rating	IP40

### Radio emissions

15.24 kHz - 72.03 kHz Only for item numbers: SV-S2.*A*, SV-S2.*AM*, SV-S2.*LN*	10 dBµA/m (3 m distance)
13.560006 MHz - 13.560780 MHz	1.04 dBµA/m (3 m distance)

868.000 MHz - 868.600 MHz / 869.700 MHz - 870.000 MHz Only for item numbers: SV-S2.*LN*, SI-S2.*M.WO*	<25 mW ERP
2402 MHz - 2480 MHz	2,5 mW

## 13. Declaration of conformity

The company SimonsVoss Technologies GmbH hereby declares that the articles (SV-S2.\*A\*, SV-S2.\*AM\*, SV-S2.\*LN\*, SI-S2.\*M.WO\*, SI-S2.\*M.VCN\*) comply with the following guidelines:

- 2014/53/EU -RED-  
or for the UK: UK statutory 2017 No. 1206 -Radio equipment-
- 2011/65/EU -RoHS-  
or for the UK: UK statutory 2012 No. 3032 -RoHS-



The full text of the EU Declaration of conformity is available at the following internet address: [www.simons-voss.com/en/certificates.html](http://www.simons-voss.com/en/certificates.html).  
The full text of the UK Declaration of conformity is available at the following internet address: [www.simons-voss.com/en/certificates.html](http://www.simons-voss.com/en/certificates.html).

## 14. Help and other information

### Information material/documents

<https://www.simons-voss.com/en/documents.html>

<https://www.smartintego.com/int/home/infocenter/documentation>

### Declarations of conformity

<https://www.simons-voss.com/en/certificates.html>

### Information on disposal

- Do not dispose the device (SV-S2.\*A\*, SV-S2.\*AM\*, SV-S2.\*LN\*, SI-S2.\*M.WO\*, SI-S2.\*M.VCN\*) in the household waste. Dispose of it at a collection point for electronic waste as per European Directive 2012/19/EU.
- Recycle defective or used batteries in line with European Directive 2006/66/EC.
- Observe local regulations on separate disposal of batteries.
- Take the packaging to an environmentally responsible recycling point.



### Email

[support-simonsvoss@allegion.com](mailto:support-simonsvoss@allegion.com)

[si-support-simonsvoss@allegion.com](mailto:si-support-simonsvoss@allegion.com)

SimonsVoss Technologies GmbH, Feringastr. 4, D-85774 Unterfoehring, Germany

## 1. Utilisation conforme

Les produits de la série SmartHandle AX sont des béquilles électroniques. Au moyen d'un support d'identification autorisé, la SmartHandle AX peut réaliser un accouplement ou ouvrir la porte correspondante.

Les autorisations correspondantes doivent être accordées au moyen d'un plan de fermeture électronique.

Les produits de la série SmartHandle AX ne doivent servir qu'à ouvrir et fermer des portes. Toute autre utilisation est interdite.

## 2. Consignes de sécurité générales

*Mot indicateur: Effets immédiats possibles du non-respect*

AVERTISSEMENT: Mort ou blessure grave (possible, mais improbable), PRU-DENCE: Blessure légère, ATTENTION: Dommages matériels ou dysfonctionnements, NOTE: Peu ou pas



### AVERTISSEMENT

#### Accès bloqué

Toute erreur de montage et/ou de programmation d'un composant peut bloquer l'accès par une porte. La société SimonsVoss Technologies GmbH décline toute responsabilité quant aux conséquences d'un accès bloqué, par exemple, accès pour les personnes blessées ou en danger, dommages matériels ou autres dommages !

#### Accès bloqué par la manipulation du produit

Si vous modifiez vous-même le produit, des dysfonctionnements peuvent se produire et l'accès peut être bloqué par une porte.

- Ne changez le produit que lorsque cela est nécessaire et de la manière décrite dans la documentation.

#### Ne pas saisir la pile. Risque de brûlures dues à des substances dangereuses

Ce produit contient des piles au lithium. En cas d'ingestion de la pile, de graves brûlures internes peuvent se produire sous deux heures et entraîner la mort.

- Conservez les piles neuves et usagées hors de portée des enfants.
- Si le compartiment à piles ne ferme pas correctement, cessez d'utiliser le produit et conservez-le hors de portée des enfants.
- En cas de suspicion d'ingestion des piles ou si celles-ci se trouvent dans une partie quelconque de votre corps, consultez immédiatement un médecin.

#### Risque d'explosion dû à un type de batterie incorrect

L'insertion d'un mauvais type de batterie peut provoquer une explosion.

- Utilisez uniquement les piles indiquées dans les données techniques.



### PRUDENCE

#### Risque d'incendie dû aux piles

En cas de manipulation impropre, les piles insérées peuvent provoquer un incendie ou des brûlures.

- Ne jamais essayer de recharger les piles, de les ouvrir, de les chauffer ou de les brûler.
- Ne pas court-circuiter les piles.

### ATTENTION

#### Endommagement lié à une décharge électrostatique (DES) lorsque le boîtier est ouvert

Ce produit contient des composants électroniques susceptibles d'être endommagés par des décharges électrostatiques.

- Utilisez du matériel de travail adapté à la DES (par ex. un bracelet de mise à la terre).
- Reliez-vous à la terre avant de commencer les travaux pendant lesquels vous pouvez être en contact avec le système électronique. Saisissez pour cela des surfaces métalliques mises à la terre (par ex. huisseries de porte, conduites d'eau ou vannes de chauffage).

#### Endommagement lié à des liquides

Ce produit contient des composants électroniques et/ou mécaniques susceptibles d'être endommagés par tout type de liquide.

- Tenez les liquides à l'écart du système électronique.

#### Endommagement lié à des nettoyeurs agressifs

La surface de ce produit peut être endommagée par des nettoyeurs inappropriés.

- Utilisez exclusivement des nettoyeurs adaptés aux surfaces plastiques ou métalliques.

#### Endommagement lié à une action mécanique

Ce produit contient des composants électroniques susceptibles d'être endommagés par une action mécanique quelconque.

- Évitez de toucher le système électronique.
- Évitez toute autre action mécanique sur le système électronique.

#### Endommagement lié à une inversion de polarité

Ce produit contient des composants électroniques susceptibles d'être endommagés par une inversion de polarité de la source de tension.

- N'inversez pas la polarité de la source de tension (piles ou blocs d'alimentation).

#### Défaillance du fonctionnement liée à une perturbation radioélectrique

Dans certaines circonstances, ce produit peut subir l'influence de perturbations électromagnétiques ou magnétiques.

- Ne montez pas et ne placez pas le produit à proximité immédiate d'appareils pouvant générer des perturbations électromagnétiques ou magnétiques (alimentations à découpage !).

#### Défaillance de la communication liée à des surfaces métalliques

Ce produit communique sans fil. Les surfaces métalliques peuvent réduire considérablement le rayon d'action du produit.

- Ne montez pas et ne placez pas le produit sur ou à proximité de surfaces métalliques.



### NOTE

#### Utilisation conforme aux dispositions

Les produits SimonsVoss sont exclusivement destinés à l'ouverture et la fermeture de portes et d'objets similaires.

- N'utilisez pas les produits SimonsVoss à d'autres fins.

#### Horaires différents pour les fermetures G2

L'unité de temps interne des fermetures G2 présente une tolérance technique pouvant atteindre ± 15 minutes par an.

#### Qualifications requises

L'installation et la mise en service nécessitent des connaissances spécialisées.

- Seul le personnel qualifié peut installer et mettre en service le produit.

#### Dysfonctionnements dus à un mauvais contact ou à une décharge différée

Des surfaces de contact trop petites/contaminées ou différentes batteries déchargées peuvent entraîner des dysfonctionnements.

- Utilisez uniquement des piles autorisées par la société SimonsVoss.
- Ne touchez pas les contacts des piles neuves avec les mains.
- Utilisez des gants propres et exempts de graisse.
- Remplacez toujours toutes les piles à la fois.

Les modifications et nouveaux développements techniques ne peuvent pas être exclus et peuvent être mis en œuvre sans préavis.

La version allemande est le manuel d'instruction original. Les autres langues (rédaction dans la langue du contrat) sont des traductions des instructions originales.

Lisez et suivez toutes les instructions d'installation, d'installation et de mise en service. Transmettez ces instructions et toutes les instructions de maintenance à l'utilisateur.

### 3. Consignes de sécurité spécifiques au produit

#### ATTENTION

##### Dommages causés par le perçage

Vous percez à vos risques et périls. SimonsVoss Technologies GmbH n'est pas responsable des dommages causés par le forage.

- Respectez également les consignes de sécurité de la perceuse.

##### Dommages causés par des outils inadaptés

Si vous essayez d'ouvrir le boîtier avec des outils inappropriés, le boîtier peut être endommagé.

- Utilisez uniquement l'outil d'ouverture SimonsVoss fourni.

##### Perte de précision du guidage de la poignée

Dans le cas de serrures encastrées avec douille de serrage, le montage peut être difficile.

- N'usinez pas la douille de serrage mécaniquement. Le guidage de la poignée perd de sa précision.

##### Montage difficile en raison de perçages imprécis

La ferrure ne peut pas être montée si les perçages de fixation et le carré ne concordent pas.

- Assurez-vous que les lignes des perçages de fixation et du carré sont parallèles verticalement.



#### NOTE

##### Les technologies active et hybride n'ont qu'une portée réduite

Les technologies actives et hybrides ont une portée nettement supérieure. En fonctionnement normal, les deux SmartHandle AX sont atteints simultanément et des erreurs de communication peuvent se produire.

- Dans le LSM/AXM, cochez la case de la portée réduite sur le SmartHandle AX pour les deux côtés.

##### Effet sur la serrure à mortaiser

La SmartHandle AX agit exclusivement sur le loquet de la serrure à mortaiser.

##### Verrouillage en vertu du droit des assurances

Les compagnies d'assurance exigent de plus en plus une fermeture.

- Si vous souhaitez verrouiller la porte en vertu du droit des assurances, utilisez une serrure antipanique autobloquante ou un cylindre de fermeture en plus de la SmartHandle AX.
- Respecter les homologations selon EN 179.

##### SmartHandle avec serrure antipanique autobloquante

Le SmartHandle AX offre uniquement une fonctionnalité complète avec une serrure antipanique autobloquante.

- Combinez la SmartHandle AX avec une serrure anti-panique autobloquante.
- Respecter les déclarations de conformité des fabricants de serrures selon EN 179.

##### Obligations relatives à la sécurité d'autorisation

Le fonctionnement avec Mifare Classic et/ou clavier PinCode exclut la sécurité d'autorisation de classe D selon DIN EN 16867:2020.

##### Fermeture de l'ouverture de la rosace

Une ouverture de rosace éventuellement existante peut être utilisée pour des manipulations.

- Fermez le cas échéant les ouvertures de rosace existantes, par exemple avec un cylindre borgne.
- Pour les variantes FH : Installez impérativement un cylindre borgne ou un cylindre de fermeture en laiton.

##### Temps de repos pour le support antidérapant

La plaque d'adaptation fournie est équipée d'un support antidérapant. Celui-ci a besoin d'un temps de prise pour avoir un effet complet.

- Après avoir installé la plaque d'adaptation, attendez cinq heures avant de poursuivre l'installation.
- Si vous devez terminer le montage au préalable : N'actionnez pas la butée jusqu'à la butée.

### 4. Contenu de la livraison

- SmartHandle AX (pour montage des deux côtés, composé de plaques d'adaptation et de la partie intérieure. Le SmartHandle AX de la partie extérieure n'est pas inclus.)

- Outil spécial
- Notice abrégée

Selon la version :

- Jeu d'adaptateurs carré 7 mm
- Douille d'adaptation carré 8,5 mm
- Douille d'adaptation carré 9 mm
- Douille d'adaptation carré 10 mm

### 5. Construction



### 6. Préparation de la porte (gabarit de perçage)

- ✓ Stylo ou pointe à tracer présent.
- ✓ Perceuse présente.
- ✓ Présence d'un foret approprié (en fonction du diamètre du trou de la serrure à mortaise : 8,5 mm/9,5 mm/10,5 mm).
- ✓ Tournevis PH2 présent.

- Insérez le carré dans la serrure à mortaise.



- Placez le gabarit de perçage sur le carré.



- Alignez le gabarit de perçage verticalement à l'aide de l'échelle imprimée.

- Marquez les points à percer sur la porte.



- Enlevez le gabarit de perçage.



- Enlevez le carré.



- Démontez la serrure à mortaise (PH2).



- Mesurez le diamètre des trous de fixation.



Ø trous de fixation	Foret requis
5,5 mm – 6,3 mm	8,5 mm
6,4 mm – 7,3 mm	8,5 mm
7,4 mm – 8,7 mm	9,5 mm
≥ 8,8 mm	10,5 mm

- Utilisez le diamètre mesuré pour déterminer le foret requis.
- Percez les trous nécessaires.



11. Montez la serrure à mortaise (PH2).



## 7. Pour épaisseur de porte X : Préparer les tiges filetées et le carré

- ✓ Scie présente.
- ✓ Pied à coulisse présent.
- ✓ Tournevis PH2 présent.

1. Pour X : Mesurez l'épaisseur de la porte.



2. Pour X : Vissez les vis, les douilles filetées et les tiges filetées ensemble.



3. Pour X : Marquez les points de sciage sur les tiges filetées et sur le carré.



4. Pour X : Raccourcissez les tiges filetées et le carré à l'aide d'une scie appropriée.



## 8. Programmation de la ferrure

Programmez la ferrure avant le montage. En fonction de la famille de produits, vous pouvez utiliser différents appareils de programmation.



## 9. Montage de la ferrure

- ✓ Porte prépercée.
- ✓ Tournevis PH2 présent.
- ✓ Tournevis TX15 présent.
- ✓ Pied à coulisse présent.
- ✓ Pince de préhension présente.

1. Pour S, M et L : Mesurez l'épaisseur de la porte.



2. Pour S, M et L : Déterminez les points de séparation sur les vis d'ajustage.



3. Pour S, M et L : Raccourcissez les vis à longueur.



4. Pour carré de 7 mm : Insérez la douille d'adaptation sur le côté du carré avec broche.



5. Insérez le carré avec le côté broche dans la ferrure.



6. Pour carré de 8,5 mm, 9 mm et 10 mm : Faites glisser la douille de l'adaptateur au centre du carré. À l'aide d'un pointeau et d'un marteau, faites un creux dans la douille de l'adaptateur pour l'empêcher de glisser.



7. Insérez la ferrure extérieure, le cas échéant avec des douilles d'adaptation, dans la porte depuis l'extérieur.



Ø trou de fixation de la serrure à mortaise	Douilles d'adaptation
5,5 mm – 6,3 mm	Pas de douille d'adaptation
6,4 mm – 7,3 mm	6,4 mm
7,4 mm – 8,7 mm	7,4 mm
≥ 8,8 mm	8,8 mm

8. Insérez la base de la rosace avec les écrous à manchon sur le côté extérieur dans la porte.



9. Placez la plaque d'adaptation sur la porte.



10. Orientez la plaque d'adaptation de manière à ce que le carré soit exactement centré et que la plaque d'adaptation soit exactement verticale.



11. Vissez la plaque d'adaptation (PH2, couple : 1,1 Nm).



12. Vissez la base de la rosace à l'intérieur.



13. Insérez le cylindre borgne.



### NOTE

#### Guider le cylindre aveugle dans le trou avec un tournevis

Il est particulièrement difficile de positionner correctement le cylindre aveugle lorsque les portes sont épaisses.

1. Insérez un tournevis dans le trou du cylindre aveugle.
2. Positionnez le cylindre aveugle au moyen du tournevis.



14. Vissez le cylindre borgne (PH2, couple de serrage : 1,1 Nm).



15. Attendez cinq heures que le revêtement antidérapant se soit fixé.



### NOTE

#### Temps de repos pour le support antidérapant

La plaque d'adaptation fournie est équipée d'un support antidérapant. Celui-ci a besoin d'un temps de prise pour avoir un effet complet.

1. Après avoir installé la plaque d'adaptation, attendez cinq heures avant de poursuivre l'installation.
2. Si vous devez terminer le montage au préalable : N'actionnez pas la béquille jusqu'à la butée.



16. Retirez le cache de protection à l'aide de l'outil.



17. Pour carré de 7 mm : Insérez la douille d'adaptation sur le carré.



18. Insérez la ferrure dans la plaque d'adaptation.



19. Tournez la ferrure en ligne droite.





20. Vissez la ferrure sur la plaque d'adaptation pour l'empêcher de tourner.



21. Enfichez le cache de protection sur la ferrure.



22. Insérez les béquilles extérieures sur les ferrures.
23. Enfichez les blindes sur les bases de rosace.
  43
24. Vissez les vis sans tête des deux béquilles (TX15, couple de serrage : 5,0 Nm).
  44

↳ Le montage de la ferrure est terminé.

## 10. Démontage de la ferrure

✓ Clé à six pans 1,5 mm disponible.

1. Démontez la ferrure dans l'ordre inverse du montage.
2. Insérez une clé hexagonale de 1,5 mm dans le trou du carré conducteur de la ferrure.



3. Pliez la clé à six pans du côté où se trouve le trou et tirez simultanément sur la béquille extérieure.



↳ La ferrure est démontée.

## 11. Remplacement des piles



### NOTE

Dysfonctionnements dus à un mauvais contact ou à une décharge différente

Des surfaces de contact trop petites/contaminées ou différentes batteries déchargées peuvent entraîner des dysfonctionnements.

1. Utilisez uniquement des piles autorisées par la société SimonsVoss.
2. Ne touchez pas les contacts des piles neuves avec les mains.
3. Utilisez des gants propres et exempts de graisse.
4. Remplacez toujours toutes les piles à la fois.

✓ Outil spécial présent.  
✓ Gants présents.

1. Insérez l'outil spécial dans l'inlay du cache de protection de la ferrure.



2. Retirez le cache de protection à l'aide de l'outil.



3. Pliez délicatement le clip de la pile vers l'intérieur pour le décrocher.



4. Ouvrez le clip de la pile.



5. Retirez le clip de la pile.



6. Retirez les piles usagées.



7. Mettez les piles neuves en place avec les pôles positifs en contact (type CR2450).



8. Remettez le clip de la pile en place.



9. Enclenchez le clip de la pile.



10. Remettez le cache de protection en place sur la ferrure.



11. Remettez en place le clip du cache de protection.



↳ Les piles sont remplacées.

## 12. Données techniques

Plage de température (fonctionnement)	de -25 °C à +50 °C
Types de piles	4 × CR2450 (3 V)
Fabricant de pile	<ul style="list-style-type: none"> <li>■ Murata</li> <li>■ Varta</li> <li>■ Panasonic</li> </ul>
Classe de protection IP	IP40

### Émissions de radio

15,24 kHz - 72,03 kHz Seulement pour les numéros d'article : SV-S2.*A*, SV-S2.*AM*, SV-S2.*LN*	10 dBµA/m (3 m distance)
13,560006 MHz - 13,560780 MHz	1,04 dBµA/m (3 m distance)
868,000 MHz - 868,600 MHz / 869,700 MHz - 870,000 MHz Seulement pour les numéros d'article : SV-S2.*LN*, SI-S2.*M.WO*	<25 mW ERP
2402 MHz - 2480 MHz	2,5 mW

## 13. Déclaration de conformité

La société SimonsVoss Technologies GmbH déclare par la présente que les articles (SV-S2.\*A\*, SV-S2.\*AM\*, SV-S2.\*LN\*, SI-S2.\*M.WO\*, SI-S2.\*M.VCN\*) est conforme aux directives suivantes:

- 2014/53/EU -RED-  
ou pour UK : UK statutory 2017 No. 1206 -Radio equipment-  
(équipement radio)
- 2011/65/UE -RoHS-  
ou pour UK : UK statutory 2012 No. 3032 -RoHS-



Le texte intégral de la déclaration de conformité CE est disponible à l'adresse Internet suivante : [www.simons-voss.com/fr/certificats.html](http://www.simons-voss.com/fr/certificats.html).  
Le texte intégral de la déclaration de conformité UK est disponible à l'adresse Internet suivante : [www.simons-voss.com/fr/certificats.html](http://www.simons-voss.com/fr/certificats.html).

## 14. Aide et autres informations

### Documentation/documents

<https://www.simons-voss.com/fr/documents.html>  
<https://www.smartintego.com/fr/home/infocenter/documentations>

### Déclarations de conformité

<https://www.simons-voss.com/fr/certificats.html>

### Informations sur l'élimination

- Ne jetez pas l'appareil (SV-S2.\*A\*, SV-S2.\*AM\*, SV-S2.\*LN\*, SI-S2.\*M.WO\*, SI-S2.\*M.VCN\*) avec vos ordures ménagères mais dans un point de collecte communal pour appareils électriques et appareils spéciaux conformément à la directive européenne 2012/19/UE.
- Recyclez les piles défectueuses ou usées conformément à la directive européenne 2006/66/CE.
- Veuillez tenir compte des dispositions locales applicables concernant la collecte séparée des piles.
- Recyclez l'emballage d'une manière écologique.



### E-Mail

[support-simonsvoss@allegion.com](mailto:support-simonsvoss@allegion.com)  
[si-support-simonsvoss@allegion.com](mailto:si-support-simonsvoss@allegion.com)

SimonsVoss Technologies GmbH, Feringastr. 4, D-85774 Unterfoehring,  
Allemagne

## 1. Beoogd gebruik

Bij de producten uit de SmartHandle AX-serie gaat het om elektronische deurbeslagen. Met behulp van een bevoegd identificatiemedium kan de SmartHandle AX activeren en de betreffende deur openen.

De bijbehorende rechten moeten met behulp van een elektronisch sluitplan worden toegewezen.

Producten uit de SmartHandle AX-serie mogen uitsluitend worden gebruikt voor het openen en sluiten van deuren. Een andersoortig gebruik is niet toegestaan.

## 2. Algemene veiligheidsinstructies

*Signaalwoord: Mogelijke onmiddellijke gevolgen van niet-naleving*

**WAARSCHUWING:** Dood of ernstig letsel (mogelijk, maar onwaarschijnlijk), **VOORZICHTIG:** Lichte letsel, LET OP: Materiële schade of storing, **OPMERKING:** Laag of nee



### WAARSCHUWING

#### Geblokkeerde toegang

Door foutief geïnstalleerde en/of geprogrammeerde componenten kan de doorgang door een deur geblokkeerd blijven. Voor gevolgen van een geblokkeerde toegang tot gewonden of personen in gevaar, materiële of andere schade, is SimonsVoss Technologies GmbH niet aansprakelijk.

#### Geblokkeerde toegang als gevolg van manipulatie van het product

Als u het product zelf wijzigt, kunnen er storingen optreden en kan de toegang worden geblokkeerd door een deur.

- Vervang het product alleen wanneer dat nodig is en op de manier die in de documentatie wordt beschreven.

#### Batterijen niet inslikken. Verbrandingsgevaar door gevaarlijke stoffen

Dit product bevat lithium-knoopcellen. Als de knoopcel wordt ingeslikt, kunnen ernstige inwendige brandwonden optreden die binnen slechts twee uur de dood veroorzaken.

1. Houd nieuwe en gebruikte batterijen buiten bereik van kinderen.
2. Als het batterijvak niet goed sluit, mag u het product niet meer gebruiken en moet u het uit de buurt van kinderen houden.
3. Als u denkt dat batterijen zijn ingeslikt of in een ander lichaamsdeel terecht zijn gekomen, moet u onmiddellijk medische hulp inroepen.

#### Explosiegevaar door verkeerd type batterij

Het plaatsen van het verkeerde type batterij kan een explosie veroorzaken.

- Gebruik alleen de in de technische gegevens vermelde batterijen.



### VOORZICHTIG

#### Brandgevaar door batterijen

De gebruikte batterijen kunnen bij verkeerde behandeling tot brand- of verbrandingsgevaar leiden.

1. Probeer niet de batterijen op te laden, open te maken, te verwarmen of te verbranden.
2. U mag de batterijen evenmin kortsluiten.

### LET OP

#### Schade door elektrostatische ontlading (ESD) wanneer de behuizing open is

Dit product heeft elektronische componenten die kunnen worden beschadigd door een elektrostatische ontlading.

1. Maak gebruik van ESD-conforme materialen (bijv. aardingsarmband).
2. Zorg dat u geaard bent voor werkzaamheden waarbij u met de elektronica in contact kunt komen. Gebruik hiervoor geaarde metalen oppervlakken (bijv. Deurposten, waterleidingen of verwarmingsbuizen).

#### Beschadiging door vloeistoffen

Dit product heeft elektronische en/of mechanische componenten die kunnen worden beschadigd door elk type vloeistof.

- Houd vloeistoffen uit de buurt van de elektronica.

#### Beschadiging door bijtende reinigingsmiddelen

Het oppervlak van dit product kan worden beschadigd door ongeschikte reinigingsmiddelen.

- Maak uitsluitend gebruik van reinigingsmiddelen die geschikt zijn voor kunststof of metalen oppervlakken.

#### Beschadiging door mechanische impact

Dit product heeft elektronische componenten die kunnen worden beschadigd door elk type mechanische impact.

1. Vermijd dat u de elektronica aanraakt.
2. Vermijd ook andere mechanische impact op de elektronica.

#### Beschadiging door verwisseling van de polariteit

Dit product bevat elektronische componenten die door verwisseling van de polariteit van de voedingsbron beschadigd kunnen worden.

- Verwissel de polariteit van de voedingsbron niet (batterijen of netadapters).

#### Storing van het gebruik door verbroken verbinding

Dit product kan onder bepaalde omstandigheden beïnvloed worden door elektromagnetische of magnetische storingen.

- Monteer of plaats het product niet direct in de buurt van apparaten die elektromagnetische of magnetische storingen kunnen veroorzaken (stroomschakelaars).

#### Storing van de communicatie door metalen oppervlakken

Dit product communiceert draadloos. Metalen oppervlakken kunnen het zendbereik van het product aanzienlijk verminderen.

- Monteer of plaats het product niet op of in de buurt van metalen oppervlakken.



### OPMERKING

#### Beoogd gebruik

SimonsVoss-producten zijn uitsluitend bedoeld voor het openen en sluiten van deuren en vergelijkbare voorwerpen.

- Gebruik SimonsVoss-producten niet voor andere doeleinden.

#### Storingen door slecht contact of verschillende ontladingen

Contactoppervlakken die te klein/vervuld zijn of verschillende ontladen accus kunnen leiden tot storingen.

1. Gebruik alleen batterijen die zijn vrijgegeven door SimonsVoss.
2. Raak de contacten van de nieuwe batterijen niet met de handen aan.
3. Gebruik schone, vetvrije handschoenen.
4. Vervang daarom alle batterijen tegelijk.

#### Afwijkende tijden bij G2-sluitelementen

De interne tijdeenheid van de G2-sluitelementen heeft een technisch bepaalde tolerantie van max. ± 15 minuten per jaar.

#### Kwalificatie vereist

De installatie en inbedrijfstelling vereist gespecialiseerde kennis. Alleen getraind personeel mag het product installeren en in bedrijf stellen.

Aanpassingen of nieuwe technische ontwikkelingen kunnen niet uitgesloten worden en worden gerealiseerd zonder aankondiging.

De Duitse taalversie is de originele handleiding. Andere talen (opstellen in de contracttaal) zijn vertalingen van de originele instructies.

Lees en volg alle installatie-, installatie- en inbedrijfstellingsinstructies. Geef deze instructies en eventuele onderhoudsinstructies door aan de gebruiker.

## 3. Specifieke veiligheidsinstructies per product

### LET OP

#### Schade door boren

U boort op eigen risico. SimonsVoss Technologies GmbH is niet aansprakelijk voor schade veroorzaakt door het boren.

- Neem ook de veiligheidsinstructies van de boormachine in acht.

**Schade veroorzaakt door ongeschikt gereedschap**

Als u de koffer probeert te openen met ongeschikt gereedschap, kan de koffer beschadigd raken.

- Gebruik uitsluitend de meegeleverde SimonsVoss-openingsstool.

**Verlies van precisie bij het bedienen van de deurkruk**

De montage kan bij insteeksloten met klem een beetje moeilijk zijn.

- Bewerk de klem niet mechanisch. Anders functioneert de deurkruk niet meer precies.

**Moelijke montage door onnauwkeurige boringen**

Het beslag is niet monteerbaar wanneer de bevestigingsgaten en het vierkant niet bij elkaar passen.

- Zorg ervoor dat de lijnen van de bevestigingsgaten en het vierkant verticaal parallel zijn.

**OPMERKING****Actieve en hybride technologie alleen met verkorte reikwijdte**

De actieve en hybride technologieën hebben een aanzienlijk groter bereik. Bij normaal bedrijf worden SmartHandle AX beide gelijktijdig bereikt en kunnen er communicatiefouten optreden.

- Activeer in de LSM/AXM voor beide zijden het SmartHandle AX selectievakje voor de verkorte reikwijdte.

**Effect op de inkepingsslot**

De SmartHandle AX werkt uitsluitend op de vergrendeling van het pennenslot.

**Vergrendeling onder het verzekeringsrecht**

Verzekeringsmaatschappijen stellen hogere eisen aan een sluiting.

- Als u de deur op grond van de verzekeringswetgeving wilt vergrendelen, gebruik dan naast de SmartHandle AX een zelfremmend paniekslot of een sluitcilinder.
- Let op de toelatingen volgens EN 179.

**SmartHandle AX met zelfblokkerende paniekslot**

De SmartHandle AX biedt alleen volledige functionaliteit met een zelfremmend paniekslot.

- Combineer de SmartHandle AX met een zelfremmend paniekslot.
- Let op de conformiteitsverklaringen van de slotfabrikanten volgens EN 179.

**Voorwaarden voor machtigingszekerheid**

Gebruik met Mifare Classic en/of PinCode keypad sluit autorisatie veiligheidsklasse D volgens DIN EN 16867:2020 uit.

**Afsluiting van de rozetopening**

Een evt. aanwezige rozetopening kan voor manipulaties worden gebruikt.

- Sluit evt. aanwezige rozetopeningen af, bijvoorbeeld met een blinde cilinder.
- Bij FH-varianten: monteer beslist een blind- of profielcilinder van mesing.

**Rusttijd voor antislip-oplegvak**

De meegeleverde adapterplaat is voorzien van een antislip-oplegvak. Deze heeft een uithardingstijd nodig om volledig in te werken.

- Wacht na de montage van de adapterplaat vijf uur voordat u verdergaat met de montage.
- Als u de montage vooraf moet voltooien: druk de deurkruk niet tot de aanslag in.

**4. Leveromvang**

- SmartHandle AX (voor montage aan beide zijden, bestaande uit adapterplaten en binnendeel. Het staande SmartHandle AX voor het buitengedeelte is niet inbegrepen.)

- Speciaal gereedschap

- Korte handleiding

Afhankelijk van de variant:

- adapterset 7 mm vierkant
- adapterhuls 8,5 mm vierkant
- Adapterhuls 9 mm vierkant
- adapterhuls 10 mm vierkant

**5. Opbouw****6. Deur voorbereiden (boormal)**

- ✓ Pen of kraspen beschikbaar.
- ✓ een boormachine beschikbaar houden.
- ✓ Geschikte boor aanwezig (afhankelijk van de diameter van het insteekslot: 8,5 mm / 9,5 mm / 10,5 mm).
- ✓ PH2-schroevendraaier beschikbaar.

- Steek het vierkant in het insteekslot.



- Plaats de boormal op het vierkant.



- Lijn de boormal verticaal uit met behulp van de opgedrukte schaalverdeling.

- Markeer de punten die geboord moeten worden op de deur.



- Verwijder de boorsjabloon.



- Verwijder het vierkant.



- Demonteer het insteekslot (PH2).



- Meet de diameter van de bevestigingsgaten.



Ø bevestigingsgaten	Benodigde boor
5,5 mm - 6,3 mm	8,5 mm
6,4 mm - 7,3 mm	8,5 mm
7,4 mm - 8,7 mm	9,5 mm
≥ 8,8 mm	10,5 mm

- Bepaal met de gemeten diameter de benodigde boor.

- Boor de benodigde gaten.



- Bouw het insteekslot in (PH2).

**7. Voor deurdikte X: schroefdraadstanden en vierkant voorbereiden**

- ✓ Zaag aanwezig.
- ✓ Schuifmaat aanwezig.
- ✓ PH2-schroevendraaier beschikbaar.

- Voor X: meet de deurdikte.



- Voor X: schroef de schroeven, de draadbussen en de draadstanden aan elkaar.



- Voor X: markeert de punten waar gezaagd moet worden op de draadstanden en op het vierkant.







4. Voor X: kort de draadstangen en het vierkant af met een geschikte zaag.



## 8. Beslag programmeren

Programmeer het beslag voor de montage. Afhankelijk van de productfamilie kunt u verschillende programmeerapparaten gebruiken.



## 9. Beslag monteren

- ✓ Deur voorgeboord.
- ✓ PH2-schroevendraaier beschikbaar.
- ✓ TX15-schroevendraaier beschikbaar.
- ✓ Schuifmaat aanwezig.
- ✓ Nijptang beschikbaar.

1. Voor S, M en L: meet de deurdikte.



2. Voor S, M en L: bepaal de scheidingspunten aan de inkortschroeven.



3. Voor S, M en L: kort de inkortschroeven in.



4. Voor 7 mm vierkant: steek de adapterhuls op de zijde van het vierkant met pin.



5. Steek het vierkant met de zijde met de pin in het beslag.

↳ Pin wordt in houder vastgeklekt.



6. Voor 8,5 mm, 9 mm en 10 mm vierkant: schuif de adapterhuls in het midden van het vierkant. Maak met een centerpons en een hamer een verdiept punt in de adapterhuls om verschuiven te voorkomen.



7. Het buitenbeslag, evt. met adapterhulzen, van buiten in de deur steken.



Ø bevestigingsgat insteekslot	Adapterhulzen
5,5 mm - 6,3 mm	Geen adapterhulzen
6,4 mm - 7,3 mm	6,4 mm
7,4 mm - 8,7 mm	7,4 mm
≥ 8,8 mm	8,8 mm

8. Steek de rozetbasis met de hulsmoeren aan de buitenzijde in de deur.



9. Plaats de adapterplaat op de deur.



10. Lijn de adapterplaat zo uit dat het vierkant precies in het midden staat en de adapterplaat precies verticaal staat.



11. Schroef de adapterplaat vast (PH2, draaimoment: 1,1 Nm).



12. Schroef de rozetbasis aan de binnenzijde vast.



13. breng de blinde cilinder aan.



### OPMERKING

#### Blinde cilinder met schroevendraaier in het gat leiden

In het bijzonder bij dikke deuren is het moeilijk om de blinde cilinder correct te positioneren.

1. Steek een schroevendraaier in het gat van de blinde cilinder.
2. Positioneer de blinde cilinder met behulp van de schroevendraaier.



14. Schroef de blinde cilinder vast (PH2, draaimoment: 1,1 Nm).



15. Wacht vijf uur totdat de antisliplaag is uitgehard.



### OPMERKING

#### Rusttijd voor antislip-oplegvlak

De meegeleverde adapterplaat is voorzien van een antislip-oplegvlak. Deze heeft een uithardingstijd nodig om volledig in te werken.

1. Wacht na de montage van de adapterplaat vijf uur voordat u verdergaat met de montage.
2. Als u de montage vooraf moet voltooien: druk de deurkruk niet tot de aanslag in.



16. Verwijder de cover met het gereedschap.



17. Voor vierkant van 7 mm: steek de adapterhuls op het vierkant.



18. Steek het beslag in de adapterplaat.



19. Draai het beslag recht.



20. Schroef het beslag vast op de adapterplaat om verdraaien te voorkomen.



21. Steek de cover op het beslag.



22. Steek de buitenklink op het beslag.

23. Steek de afdekkingen op de rozetbasissen.



24. Schroef de stiftappen van beide deurkrukken vast (TX15, draaimoment: 5,0 Nm).



↳ Beslag is gereed gemonteerd.

## 10. Beslag demonteren

- ✓ 1,5 mm inbus sleutel beschikbaar.

1. Demonteer het beslag in omgekeerde volgorde van de montage.

2. Steek een inbus sleutel van 1,5 mm in het gat van de opname voor de vierkantstift in het beslag.



3. Buig de inbus sleutel naar de zijde waar het gat zich bevindt en trek tegelijkertijd aan de buitendeurkruk.



↳ Beslag is gedemonteerd.

## 11. Batterijen vervangen



### OPMERKING

#### Storingen door slecht contact of verschillende ontladingen

Contactoppervlakken die te klein/vervuld zijn of verschillende ontladen accu's kunnen leiden tot storingen.

1. Gebruik alleen batterijen die zijn vrijgegeven door SimonsVoss.
2. Raak de contacten van de nieuwe batterijen niet met de handen aan.
3. Gebruik schone, vetvrije handschoenen.
4. Vervang daarom alle batterijen tegelijk.

- ✓ Speciaal gereedschap beschikbaar.
- ✓ Handschoenen aanwezig.

1. Steek het speciale gereedschap in de cover-inlay van het beslag.



47

2. Verwijder de cover met het gereedschap.



48



49

3. Buig de batterijklem voorzichtig naar binnen om hem los te haken.



50



51

4. Open de batterijklem.



52

5. Trek de batterijklem eruit.



53

6. Verwijder de oude batterijen.



54

7. Zet de nieuwe batterijen in met de pluspolen tegen elkaar (type CR2450).



55

8. Zet de batterijklem er weer in.



56

9. Haak de batterijklem weer vast.



57

10. Plaats de cover weer op het beslag.



58

11. Klik de cover weer vast.



59

- ↳ De batterijen zijn vervangen.

## 12. Technische gegevens

Temperatuurbereik (bedrijf)	-25°C tot +50°C
Soort batterij	4x CR2450 (3V)
Batterijmerk	<ul style="list-style-type: none"> <li>■ Murata</li> <li>■ Varta</li> <li>■ Panasonic</li> </ul>
IP-beschermingsklasse	IP40

### Radio-emissies

15,24 kHz - 72,03 kHz Alleen voor artikelnummers: SV-S2.*A*, SV-S2.*AM*, SV-S2.*LN*	10 dBµA/m (3 m afstand)
13,560006 MHz - 13,560780 MHz	1,04 dBµA/m (3 m afstand)

868,000 MHz - 868,600 MHz / 869,700 MHz - 870,000 MHz Alleen voor artikelnummers: SV-S2.*LN*, SI-S2.*M.WO*	<25 mW ERP
2402 MHz - 2480 MHz	2,5 mW

## 13. Verklaring van overeenstemming

Het bedrijf SimonsVoss Technologies GmbH verklaart dat de artikelen (SV-S2.\*A\*, SV-S2.\*AM\*, SV-S2.\*LN\*, SI-S2.\*M.WO\*, SI-S2.\*M.VCN\*) voldoen aan de volgende richtlijnen:

- 2014/53/EU -RED-  
of voor de UK: UK wettelijk 2017 Nr. 1206 -Radioapparatuur-
- 2011/65/EU -RoHS-  
of voor de UK: UK wettelijk 2012 Nr. 3032 -RoHS-



De volledige tekst van de EU-conformiteitsverklaring is beschikbaar op het volgende internetadres: [www.simons-voss.com/nl/certificaten.html](http://www.simons-voss.com/nl/certificaten.html).  
De volledige tekst van de UK-conformiteitsverklaring is beschikbaar op het volgende internetadres: [www.simons-voss.com/nl/certificaten.html](http://www.simons-voss.com/nl/certificaten.html).

## 14. Hulp en verdere informatie

### Informatiemateriaal/documenten

<https://www.simons-voss.com/nl/documenten.html>  
<https://www.smartintego.com/int/home/infocenter/documentation>

### Conformiteitsverklaringen

<https://www.simons-voss.com/nl/certificaten.html>

### Informatie over verwijdering

- Voer het apparaat (SV-S2.\*A\*, SV-S2.\*AM\*, SV-S2.\*LN\*, SI-S2.\*M.WO\*, SI-S2.\*M.VCN\*) niet af als huishoudelijk afval, maar overeenkomstig de Europese Richtlijn 2012/19/EU bij een gemeentelijke inzamelingspunt voor speciaal elektrotechnisch afval.
- Zorg voor recycling van defecte of gebruikte batterijen volgens de Europese Richtlijn 2006/66/EG.
- Neem de plaatselijke bepalingen in acht voor de gescheiden afvoer van batterijen.
- Voer de verpakking af naar een instantie voor milieuvriendelijke recycling.



60

### E-mail

[support-simonsvoss@allegion.com](mailto:support-simonsvoss@allegion.com)  
[si-support-simonsvoss@allegion.com](mailto:si-support-simonsvoss@allegion.com)

SimonsVoss Technologies GmbH, Feringastr. 4, 85774 Unterföhring, Duitsland

## 1. Uso conforme

I prodotti della serie SmartHandle AX sono maniglie elettroniche. Con l'ausilio di un mezzo di identificazione autorizzato SmartHandle AX può innestarsi e aprire la porta corrispondente.

Le relative autorizzazioni devono essere rilasciate con l'ausilio di un piano di chiusura elettronico.

I prodotti della serie SmartHandle AX possono essere utilizzati solo per l'apertura e la chiusura delle porte. Qualsiasi altro uso non è consentito.

## 2. Avvisi di sicurezza generali

*Parola segnale: Possibili effetti immediati di non conformità*

**AVVERTENZA:** Morte o lesioni gravi (possibili, ma improbabili), ATTENZIONE: Lesione minori, **AVVISO:** Danni materiali o malfunzionamento, **NOTA:** Basso o no



### AVVERTENZA

#### Accesso bloccato

Con componenti montati e/o programmati in modo difettoso, l'accesso attraverso una porta può restare bloccato. La SimonsVoss Technologies GmbH non risponde delle conseguenze di un accesso bloccato, per esempio nel caso si debba accedere a persone ferite o in pericolo, di danni a cose o altri danni!

#### Accesso bloccato tramite manipolazione del prodotto

Se si modifica il prodotto da solo, possono verificarsi malfunzionamenti e l'accesso attraverso una porta può essere bloccato.

- Modificare il prodotto solo quando necessario e solo nel modo descritto nella documentazione.

#### Non ingerire la batteria. Pericolo di ustioni dovute a sostanze pericolose

Questo prodotto contiene batterie a bottone al litio. Se la batteria a bottone viene inghiottita, possono verificarsi gravi ustioni interne nel giro di sole due ore che possono causare la morte.

1. Conservare le batterie nuove e usate lontano dalla portata dei bambini.
2. Se il vano batteria non si chiude in modo sicuro, interrompere l'uso del prodotto e tenerlo lontano dalla portata dei bambini.
3. Se pensate che le batterie siano state inghiottite o si trovino in una qualsiasi parte del vostro corpo, rivolgetevi immediatamente a un medico.

#### Pericolo di esplosione a causa di un tipo di batteria non corretto

L'inserimento del tipo di batteria sbagliato può causare un'esplosione.

- Utilizzare solo le batterie specificate nei dati tecnici.



### ATTENZIONE

#### Pericolo di incendio dovuto alle batterie

Le batterie utilizzate possono costituire un pericolo di incendio o combustione in caso di utilizzo scorretto.

1. Non tentare di caricare, aprire, riscaldare o bruciare le batterie.
2. Non cortocircuitare le batterie.

### AVVISO

#### Danni dovuti a scariche elettrostatiche (ESD) quando l'alloggiamento è aperto

Il presente prodotto contiene componenti elettronici che potrebbero subire danni in conseguenza di scariche elettrostatiche.

1. Utilizzare materiali di lavori conformi ai requisiti ESD (ad es. fascetta antistatica al polso).
2. Effettuare la messa a terra dell'operatore prima di eseguire lavori in cui è possibile entrare in contatto con parti elettroniche. A tale scopo, toccare una superficie metallica opportunamente messa a terra (ad es. telaio porta, tubi dell'acqua o valvole di riscaldamento).

#### Danni dovuti a fluidi

Il presente prodotto contiene componenti elettronici e/o meccanici che potrebbero subire danni dovuti a liquidi di qualunque tipo.

- Tenere i componenti elettronici lontani da liquidi.

#### Danni dovuti a detergenti aggressivi

La superficie di questo prodotto può essere danneggiata da detergenti non idonei.

- Utilizzare esclusivamente detergenti adatti a superfici in plastica o metallo.

#### Danni dovuti a effetti meccanici

Il presente prodotto contiene componenti elettronici che potrebbero subire danni dovuti a effetti meccanici di qualunque tipo.

1. Evitare di toccare le parti elettroniche.
2. Evitare ulteriori effetti meccanici sulle parti elettroniche.

#### Danni dovuti all'inversione di polarità

Questo prodotto contiene componenti elettronici che possono essere danneggiati dall'inversione di polarità della sorgente di tensione.

- Non invertire la polarità della sorgente di tensione (batterie o alimentatori).

#### Funzionamento disturbato a causa di interferenze radioelettriche

Questo prodotto potrebbe essere influenzato da disturbi elettromagnetici o magnetici.

- Non montare o posizionare il prodotto direttamente accanto a dispositivi che possono causare interferenze elettromagnetiche o magnetiche (alimentatori switching!).

#### Interferenze nella comunicazione dovute a superfici metalliche

Questo prodotto comunica in modalità wireless. Le superfici metalliche possono ridurre significativamente la portata del prodotto.

- Non montare o posizionare il prodotto sopra o vicino a superfici metalliche.



### NOTA

#### Uso conforme

I prodotti SimonsVoss sono concepiti esclusivamente per l'apertura e la chiusura di porte e oggetti simili.

- Non utilizzare i prodotti SimonsVoss per altri scopi.

#### Malfunzionamenti dovuti a contatto insufficiente o a scarichi diversi

Superfici di contatto troppo piccole/contaminate o diverse batterie scariche possono portare a malfunzionamenti.

1. Utilizzare esclusivamente batterie autorizzate da SimonsVoss.
2. Non toccare con le mani i contatti delle nuove batterie.
3. Utilizzare guanti puliti e privi di grasso.
4. Sostituire sempre tutte le batterie contemporaneamente.

#### Tempi diversi per chiusure G2

L'unità temporale interna delle chiusure G2 è tecnicamente vincolata a una tolleranza fino a  $\pm 15$  minuti all'anno.

#### Qualifiche richieste

L'installazione e la messa in servizio richiedono conoscenze specialistiche.

- Solo personale qualificato può installare e mettere in servizio il prodotto.

Non si escludono modifiche o perfezionamenti tecnici, anche senza preavvisi.

La versione in lingua tedesca è il manuale di istruzioni originale. Altre lingue (redazione nella lingua del contratto) sono traduzioni delle istruzioni originali.

Leggere e seguire tutte le istruzioni di installazione, installazione e messa in servizio. Passare queste istruzioni e tutte le istruzioni di manutenzione all'utente.

## 3. Avvertenze di sicurezza specifiche del prodotto

### AVVISO

#### Danni da perforazione

Esercitate a vostro rischio e pericolo. SimonsVoss Technologies GmbH non è responsabile dei danni causati dalla perforazione.

- Osservare anche le norme di sicurezza del trapano.

#### Danni causati da utensili non idonei

Se si tenta di aprire la custodia con strumenti inadeguati, la custodia può essere danneggiata.

- Utilizzare solo l'utensile di apertura SimonsVoss in dotazione.

#### La maniglia non ha più una guida precisa

In caso di serrature ad incasso dotate di perno di riscontro, il montaggio della SmartHandle può risultare leggermente difficoltoso.

- Non modificare meccanicamente il perno di riscontro, poiché altrimenti la maniglia non avrà più una guida precisa.

#### Montaggio difficoltoso a causa di fori imprecisi

La maniglia non si può montare, quando i fori di fissaggio e il quadro maniglia non combaciano.

- Assicurarsi che le linee dei fori di fissaggio e del quadro maniglia risultino parallele in senso verticale.



### NOTA

#### Tecnologia attiva e ibrida solo con portata ridotta

Le tecnologie attive e ibride hanno un'autonomia significativamente maggiore. Con il funzionamento normale le due SmartHandle AX vengono raggiunte allo stesso tempo e questo può causare errori di comunicazione.

- Attivare la casella di controllo per la portata ridotta in LSM/AXM per ambedue i lati su SmartHandle AX.

#### Effetto sulla serratura da infilare

SmartHandle AX agisce esclusivamente sullo scrocco della serratura da infilare.

#### Blocco secondo la legge sulle assicurazioni

Le compagnie di assicurazione pongono maggiori richieste di chiusura.

- Se si desidera chiudere la porta secondo la legge sull'assicurazione, oltre alla SmartHandle AX si può utilizzare una serratura antipanico autobloccante o un cilindro di chiusura.
- Prestare attenzione alle omologazioni secondo EN 179.

#### SmartHandle AX con serratura antipanico autobloccante

SmartHandle AX offre tutte le funzionalità solo con una serratura antipanico autobloccante.

- Combinare il SmartHandle AX con una serratura antipanico autobloccante.
- Prestare attenzione alle dichiarazioni di conformità dei produttori di serrature secondo EN 179.

#### Condizioni per la sicurezza dell'autorizzazione

Il funzionamento con la tastiera Mifare Classic e/o PinCode esclude la classe di sicurezza di autorizzazione D secondo la norma DIN EN 16867:2020.

#### Chiusura dell'apertura delle rosette

Per le manipolazioni è possibile utilizzare l'apertura delle rosette ev. presenti.

- Chiudere le aperture delle rosette ev. presenti, ad esempio con un cilindro cieco.
- Per le varianti FH: installare obbligatoriamente un cilindro cieco o di chiusura in ottone.

#### Tempo di riposo per rivestimento antiscivolo

La piastra adattatrice in dotazione è provvista di rivestimento antiscivolo, che richiede un tempo di assestamento per avere pieno effetto.

- Attendere cinque ore dopo il montaggio della piastra adattatrice, prima di proseguire il montaggio.
- Nel caso in cui si debba terminare prima il montaggio: non azionare la maniglia fino all'arresto.

## 4. Oggetto di fornitura

- SmartHandle AX (per il montaggio su entrambi i lati, composto da piastre adattatrici e parte interna. La SmartHandle AX verticale per la parte esterna non è inclusa).

- Attrezzo speciale

- Libretto di istruzioni

A seconda della variante:

- Set di adattatori quadro maniglia di 7 mm
- Manicotto adattatore quadro maniglia di 8,5 mm
- Manicotto adattatore quadro maniglia di 9 mm
- Manicotto adattatore quadro maniglia di 10 mm

## 5. Struttura



## 6. Preparazione della porta (maschera di foratura)

- ✓ Perno o punta per tracciare a disposizione.
- ✓ Trapano a disposizione.
- ✓ Punta adatta a disposizione (in base al diametro del foro della serratura a incasso: 8,5 mm / 9,5 mm / 10,5 mm).
- ✓ Cacciavite PH2 a disposizione.

- Inserire il quadro maniglia nella serratura a incasso.



- Applicare la maschera di foratura sul quadro maniglia.



- Allineare la maschera di foratura in verticale con l'ausilio della scala graduata.

- Segnare i punti da forare sulla porta.



- Rimuovere la maschera di foratura.



- Rimuovere il quadro maniglia.



- Rimuovere la serratura a incasso (PH2).



- Misurare il diametro dei fori di fissaggio.



Ø fori di fissaggio	Punta necessaria
5,5 mm - 6,3 mm	8,5 mm
6,4 mm - 7,3 mm	8,5 mm
7,4 mm - 8,7 mm	9,5 mm
≥8,8 mm	10,5 mm

- Determinare la punta necessaria con il diametro misurato.

- Praticare i fori necessari.



11. Inserire la serratura a incasso (PH2).



## 7. Per lo spessore della porta X: preparazione delle aste filettate e del quadro maniglia

- ✓ Sega a disposizione.
- ✓ Calibro a disposizione.
- ✓ Cacciavite PH2 a disposizione.

1. Per X: misurare lo spessore della porta.



2. Per X: avvitare le viti, i manicotti filettati e le aste filettate.



3. Per X: contrassegnare i punti da segare sulle aste filettate e sul quadro maniglia.



4. Per X: accorciare le aste filettate e il quadro maniglia con una sega adatta.



## 8. Programmare la maniglia

Programmare la maniglia prima del montaggio. È possibile utilizzare diversi dispositivi di programmazione a seconda della famiglia di prodotti.



## 9. Beschlag montieren

- ✓ Porta già forata.
- ✓ Cacciavite PH2 a disposizione.
- ✓ Cacciavite TX15 a disposizione.
- ✓ Calibro a disposizione.
- ✓ Tenaglia a disposizione.

1. Per S, M e L: misurare lo spessore della porta.



2. Per S, M e L: determinare i punti di separazione sulle viti a colletto.



3. Per S, M e L: accorciare le viti a colletto.



4. Per il quadro maniglia di 7 mm: applicare il manicotto adattatore sul lato del quadro maniglia con pin.



5. Applicare il quadro maniglia con il lato pin nella maniglia.

↳ Il pin si chiude a scatto nell'alloggiamento.



6. Per il quadro maniglia di 8,5 mm, 9 mm e 10 mm: spingere il manicotto adattatore al centro del quadro maniglia. Con un martello e un punzone realizzare un incavo nel manicotto adattatore per impedire che si muova.



7. Inserire la maniglia esterna, ev. con manicotti adattatori, dal lato esterno nella porta.



Ø foro di fissaggio della serratura a incasso	Manicotti adattatori
5,5 mm - 6,3 mm	Nessun manicotto adattatore
6,4 mm - 7,3 mm	6,4 mm
7,4 mm - 8,7 mm	7,4 mm
≥ 8,8 mm	8,8 mm

8. Inserire il portarosetta con i dadi a manicotto sul lato esterno nella porta.



9. Poggiare la piastra adattatrice sulla porta con.



10. Allineare la piastra adattatrice in modo che il quadro maniglia si trovi esattamente al centro e la piastra adattatrice sia esattamente verticale.



11. Avvitare saldamente la piastra adattatrice (PH2, coppia: 1,1 Nm).



12. Avvitare saldamente il portarosetta sul lato interno.



13. Inserire il cilindro cieco.



### NOTA

#### Posizionare il cilindro cieco nel foro utilizzando il cacciavite

Soprattutto per le porte di grande spessore, è difficile posizionare correttamente il cilindro cieco.

1. Inserire un cacciavite nel foro del cilindro cieco.
2. Posizionare il cilindro cieco con l'ausilio del cacciavite.



14. Avvitare saldamente il cilindro cieco (PH2, coppia: 1,1 Nm).



15. Attendere cinque ore, fino a che il rivestimento antiscivolo si sia assestato.



### NOTA

#### Tempo di riposo per rivestimento antiscivolo

La piastra adattatrice in dotazione è provvista di rivestimento antiscivolo, che richiede un tempo di assestamento per avere pieno effetto.

1. Attendere cinque ore dopo il montaggio della piastra adattatrice, prima di proseguire il montaggio.
2. Nel caso in cui si debba terminare prima il montaggio: non azionare la maniglia fino all'arresto.



16. Togliere la cover con l'attrezzo.



17. Per il quadro maniglia di 7 mm: applicare il manicotto adattatore sul maniglia.



18. Inserire la maniglia nella piastra adattatrice.



19. Ruotare subito la maniglia.



20. Avvitare saldamente la maniglia sulla piastra adattatrice, per impedire la torsione.



21. Applicare la cover sulla maniglia.



42

22. Applicare le maniglie esterne sulle maniglie.

23. Applicare le coperture sui portarosse.



43

24. Avvitare saldamente le vite senza testa di entrambe le maniglie (TX15, coppia: 5,0 Nm).



44

- ↳ La maniglia è completamente montata.

## 10. Smontaggio della maniglia

- ✓ Chiave esagonale da 1,5 mm disponibile.

1. Smontare la maniglia procedendo nella sequenza opposta rispetto al montaggio.

2. Inserire una chiave esagonale da 1,5 mm nel foro dell'alloggiamento del quadro maniglia nella maniglia.



45

3. Girare la chiave esagonale dal lato sul quale si trova il foro e contemporaneamente tirare la maniglia esterna.



46

- ↳ La maniglia è smontata.

## 11. Sostituzione delle batterie



### NOTA

#### Malfunzionamenti dovuti a contatto insufficiente o a scarichi diversi

Superfici di contatto troppo piccole/contaminate o diverse batterie scariche possono portare a malfunzionamenti.

- Utilizzare esclusivamente batterie autorizzate da SimonsVoss.
- Non toccare con le mani i contatti delle nuove batterie.
- Utilizzare guanti puliti e privi di grasso.
- Sostituire sempre tutte le batterie contemporaneamente.

- ✓ Attrezzo speciale a disposizione.

- ✓ Guanti a disposizione.

1. Inserire l'attrezzo speciale nell'inserto della cover della maniglia.



47

2. Togliere la cover con l'attrezzo.



48



49

3. Piegare con cautela il morsetto della batteria verso l'interno, per sgan-  
ciarli.



50



51

4. Aprire il morsetto della batteria.



52

5. Estrarre il morsetto della batteria.



53

6. Rimuovere le vecchie batterie.



54

7. Inserire le batterie nuove in modo tale che i poli positivi si tocchino (tipo  
CR2450).



55

8. Reinserire la morsetto della batteria.



56

9. Agganciare nuovamente il morsetto della batteria.



57

10. Applicare nuovamente la cover sulla maniglia.



58

11. Reintegrare saldamente la cover.



59

- ↳ Le batterie sono sostituite.

## 12. Dati tecnici

Range di temperature (esercizio)	da -25 °C a +50 °C
Tipo di batteria	4× CR2450 (3V)
Marca delle batterie	<ul style="list-style-type: none"> <li>■ Murata</li> <li>■ Varta</li> <li>■ Panasonic</li> </ul>
Grado di protezione	IP40

### Emissioni radio

15,24 kHz - 72,03 kHz Solo per i codici articolo: SV-S2.*A*, SV-S2.*AM*, SV-S2.*LN*	10 dBµA/m (3 m distanza)
13,560006 MHz - 13,560780 MHz	1,04 dBµA/m (3 m distanza)
868,000 MHz - 868,600 MHz / 869,700 MHz - 870,000 MHz Solo per i codici articolo: SV- S2.*LN*, SI-S2.*M.WO*	<25 mW ERP
2402 MHz - 2480 MHz	2,5 mW

## 13. Dichiarazione di conformità

Het bedrijf SimonsVoss Technologies GmbH verklaart hierbij dat de artikelen (SV-S2.\*A\*, SV-S2.\*AM\*, SV-S2.\*LN\*, SI-S2.\*M.WO\*, SI-S2.\*M.VCN\*) vol-  
doet aan de volgende richtlijnen:

- 2014/53/UE -RED-  
o per il Regno Unito: Normativa del Regno Unito 2017 n. 1206  
-Apparecchiature radio-
- 2011/65/UE -RoHS-  
o per il Regno Unito: Normativa del Regno Unito 2012 n. 3032 -RoHS-



Il testo integrale della dichiarazione di conformità UE è disponibile al seguen-  
te indirizzo Internet: [www.simons-voss.com/it/certificati.html](http://www.simons-voss.com/it/certificati.html).

Il testo integrale della dichiarazione di conformità UK è disponibile al seguen-  
te indirizzo Internet: [www.simons-voss.com/it/certificati.html](http://www.simons-voss.com/it/certificati.html).

## 14. Supporto e ulteriori informazioni

### Materiale informativo/Documents

<https://www.simons-voss.com/it/documents.html>

<https://www.smartintego.com/int/home/infocenter/documentation>

### Dichiarazioni di conformità

<https://www.simons-voss.com/it/certificati.html>

### Informazioni sullo smaltimento

- Il dispositivo (SV-S2.\*A\*, SV-S2.\*AM\*, SV-S2.\*LN\*, SI-S2.\*M.WO\*, SI-  
S2.\*M.VCN\*) non va smaltito fra i rifiuti domestici, ma conferito presso  
un centro di raccolta comunale per rifiuti elettronici speciali in  
conformità con la Direttiva Europea 2012/19/UE.
- Riciclare le batterie guaste o esauste ai sensi della Direttiva Europea  
2006/66/CE.
- Osservare le disposizioni locali in materia di smaltimento speciale delle  
batterie.
- Conferire l'imballaggio presso un punto di raccolta ai fini del riciclaggio  
ecologico.



## E-mail

*support-simonsvoss@allegion.com*

*si-support-simonsvoss@allegion.com*

SimonsVoss Technologies GmbH, Feringastr. 4, D-85774 Unterfoehring,  
Germany

## 1. Anvendelsesområder

Ved SmartHandle AX-seriens produkter drejer det sig om elektroniske dørbeslag. SmartHandle AX kan koble ind og åbne den pågældende dør ved hjælp af et adgangsberegtiget identifikationsmedium.

Tilsvarende adgangsbrettigheder skal tildeles ved hjælp af en elektronik låseplan.

SmartHandle AX-seriens produkter må kun bruges til åbning og lukning af døre. Anden anvendelse er ikke tilladt.

## 2. Generelle sikkerhedshenvisninger

*Signalford: Mulige direkte virkninger i tilfælde af manglende overholdelse*

ADVARSEL: Død eller alvorlig personskade (muligt, men usandsynligt), FOR-SIGTIG: Mindre skade, OPM/ERKSOMHED: Materiel skade eller fejlfunktion, BEM/ERK: Lidt eller ingen



### ADVARSEL

#### Spærret adgang

Hvis komponenter er fejlagtigt monteret og/eller programmeret, kan adgang til en dør forblive spærret. For følgeskader, der skyldes spærret adgang, fx til personer, der er sårede eller i fare, tingsskader eller andre skader, hæfter SimonsVoss Technologies GmbH ikke!

#### Blokeret adgang gennem manipulation af produktet

Hvis du selv ændrer produktet, kan der opstå funktionsfejl, og adgang via en dør kan blokeres.

- Modificer kun produktet, når det er nødvendigt, og kun på den måde, der er beskrevet i dokumentationen.

#### Batteri må ikke indtages. Forbrændingsfare på grund af farlige stoffer

Dette produkt indeholder litium-knappceller. Hvis knapcellen sluges, kan det medføre alvorlige indre forbrændinger inden for to timer og dødsfald.

1. Opbevar nye og brugte batterier uden for børns rækkevidde.
2. Hvis batterirummet ikke kan lukkes ordentligt, må produktet ikke længere benyttes, og det opbevares uden for børns rækkevidde.
3. Hvis du tror, at batterier er blevet slugt eller befinder sig i en legemsdel, skal du straks søge lægehjælp.

#### Eksplodingsfare på grund af forkert batteritype

Isætning af den forkerte batteritype kan resultere i en eksplosion.

- Brug kun de batterier, der er specificeret i de tekniske data.



### FORSIGTIG

#### Brandfare ved batterier

Batterierne kan udgøre en brand- eller forbrændingsfare ved forkert behandling.

1. Forsøg ikke at oplade, åbne, opvarme eller brænde batterierne.
2. Kortslut ikke batterierne.

### OPM/ERKSOMHED

#### Beskadigelse på grund af elektrostatisk afladning (ESD) med huset åbent

Dette produkt indeholder elektroniske komponenter, som kan blive beskadiget på grund af elektrostatisk afladning.

1. Brug ESD-beskyttede arbejdsmaterialer (f.eks. jordforbindelsesbånd).
2. Opret jordforbindelse før arbejde, hvor du kan komme i kontakt med elektronikken. Indfat i denne forbindelse jordforbundne metaloverflader (f.eks. dørkarme, vandrør eller varmeventiler).

#### Beskadigelse på grund af væsker

Dette produkt indeholder elektroniske og/eller mekaniske komponenter, som kan blive beskadiget på grund af alle typer væsker.

- Hold væsker væk fra elektronikken.

#### Beskadigelse på grund af aggressive rengøringsmidler

Produktets overflade kan blive beskadiget på grund af uegnede rengøringsmidler.

- Brug kun rengøringsmidler, der er velegnede til kunststof- og metaloverflader.

#### Beskadigelse på grund af mekanisk påvirkning

Dette produkt indeholder elektroniske komponenter, som kan blive beskadiget på grund af alle typer mekanisk påvirkning.

1. Undgå at berøre elektronikken.
2. Undgå at udsætte elektronikken for andre mekaniske påvirkninger.

#### Beskadigelse på grund af fejltilslutning

Dette produkt indeholder elektroniske komponenter, som kan blive beskadiget på grund af fejltilslutning af spændingskilden.

- Sørg for ikke at fejltilslutte spændingskilden (batterier eller netdele).

#### Driftsforstyrrelse på grund af radiostøj

Dette produkt kan under visse omstændigheder påvirkes af elektromagnetiske eller magnetiske forstyrrelser.

- Monter eller anbring ikke produktet umiddelbart i nærheden af enheder, som kan medføre elektromagnetiske eller magnetiske forstyrrelser (strømforsyninger!).

#### Kommunikationsfejl på grund af metaloverflader

Dette produkt kommunikerer trådløst. Metaloverflader kan reducere produktets rækkevidde væsentligt.

- Monter eller anbring ikke produktet på eller i nærheden af metaloverflader.



### BEM/ERK

#### Korrekt anvendelse

SimonsVoss-produkter er kun beregnet til åbning og lukning af døre og sammenlignelige genstande.

- Anvend ikke SimonsVoss-produkter til andre formål.

#### Funktionsfejl på grund af dårlig kontakt eller anden afladning

For små / forurenede kontaktområder eller forskellige afladede batterier kan føre til funktionsfejl.

1. Anvend kun batterier, som er frigivet af SimonsVoss.
2. Berør ikke de nye batteriers kontakter med hænderne.
3. Anvend rene og fedtfrie handsker.
4. Skift derfor altid alle batterier samtidigt.

#### Afvigende tidspunkter ved G2-lukninger

Den interne tidsenhed ved G2-lukninger har en teknisk betinget tolerance på op til ± 15 minutter om året.

#### Krævede kvalifikationer

Installation og driftsættelse kræver specialiseret viden.

- Kun uddannet personale må installere og idriftsætte produktet.

Ændringer eller tekniske videreudviklinger kan ikke udelukkes og kan foretages uden forudgående varsel.

Den tyske sprogversion er den originale brugsanvisning. Andre sprog (udkast på kontraktspøget) er oversættelser af de originale instruktioner.

Læs og følg alle installations-, installations- og idriftsættelsesinstruktioner. Overfør disse instruktioner og eventuel vedligeholdelsesinstruktion til brugeren.



### 3. Produktspecifikke sikkerhedsanvisninger

#### OPMÆRKSOMHED

##### Skade ved boring

De borer på egen risiko. For skader forårsaget af boring er SimonsVoss Technologies GmbH ikke ansvarlig.

- Overhold også borens sikkerhedsinstruktioner.

##### Skader på grund af uegnet værktøj

Forsøg på at åbne sagen med et forkert værktøj kan beskadige sagen.

- Brug kun det medfølgende SimonsVoss åbningsværktøj.

##### Tab af præcis føring af håndtag

Montagen kan være stram ved indstikslåse med låsekasse.

- Låsekassen må ikke bearbejdes mekanisk. Håndtaget mister sin nøjagtige føring.

##### Vanskelig montering på grund af unøjagtige borehuller

Beslaget kan ikke monteres, hvis monteringshullerne og firkanten ikke passer sammen.

- Sørg for, at linjerne i monteringshullerne og firkanten er lodret parallelle.



#### BEMÆRK

##### Aktiv og hybrid teknologi kun med kortere rækkevidde

De aktive og hybride teknologier har en betydeligt større rækkevidde. Ved normal drift bliver de to SmartHandle AX nået på samme tid, og der kan opstå kommunikationsfejl.

- Aktivér i LSM/AXM for begge sider på SmartHandle AX afkrydsningsfeltet for den forkortede rækkevidde.

##### Effekt på indlåsningsslåsen

SmartHandle AX fungerer udelukkende på låsen på låseåbningen.

##### Lukningsforsikringslov

Forsikringssselskaber stiller større krav til lukning.

- Hvis du vil lukke døren under forsikringsloven, skal du bruge en selvlåsende paniklås eller en låsecylinder ud over SmartHandle AX.
- Vær opmærksom på godkendelserne i henhold til EN 179.

##### SmartHandle AX med selvlåsende paniklås

SmartHandle AX tilbyder kun fuld funktionalitet med en selvlåsende paniklås.

- Kombiner SmartHandle AX med en selvlåsende paniklås.
- Vær opmærksom på låsefabrikantens overensstemmelseserklæringer i henhold til EN 179.

##### Betingelser for sikkerhedsstillelse i forbindelse med tilladelsen

Drift med Mifare Classic- og/eller PinCode-tastatur udelukker autorisation sikkerhedsklasse D i henhold til DIN EN 16867:2020.

##### Lukning af rosetåbning

En evt. eksisterende åbning i rosetten kan bruges til manipulationer.

- Luk evt. eksisterende åbninger i rosetten, f.eks. med en blindcylinder.
- Ved FH-varianten: Det er vigtigt at montere en blindcylinder eller låsecylinder af messing.

##### Hviletid for skridsikker støtte

Den medfølgende adapterplade er udstyret med en skridsikker støtte. Denne kræver en indstillings tid for at få fuld effekt.

- Efter montering af adapterpladen skal du vente fem timer, før du fortsætter med monteringen.
- Hvis du er nødt til at færdigmontere tidligere: Tryk ikke håndtaget ind til anslag.

### 4. Leveringsomfang

- SmartHandle AX (til montering på begge sider, bestående af adapterplader og indvendig del. Den stående SmartHandle AX til den udvendige del er ikke inkluderet.)

- Specialværktøj

- Kort vejledning

Afhængigt af variant:

- Adaptersæt 7 mm firkant
- Adaptertylle 8,5 mm firkant
- Adaptertylle 9 mm firkant
- Adaptertylle 10 mm firkant

### 5. Montering



### 6. Forbered døren (boreskabelon)

- Blyant eller ridsenål til stede.
- Boremaskine til rådighed.
- Passende bor til rådighed (afhængigt af indstikslåsens hul diameter: 8,5 mm / 9,5 mm / 10,5 mm).
- PH2-skruetrækker til rådighed.

- Sæt firkanten ind i indstikslåsen.



- Sæt boreskabelonen på firkanten.



- Juster boreskabelonen lodret ved hjælp af den påtrykte skala.

- Marker de punkter, der skal bores på døren.



- Fjern boreskabelonen.



- Fjern firkanten.



- Afmonter indstikslåsen (PH2).



- Mål diameteren på monteringshullerne.



Ø monteringshuller	Nødvendigt bor
5,5 mm - 6,3 mm	8,5 mm
6,4 mm - 7,3 mm	8,5 mm
7,4 mm - 8,7 mm	9,5 mm
≥ 8,8 mm	10,5 mm

- Bestem det nødvendige bor med den målte diameter.

- Bor de nødvendige huller.



- Monter indstikslåsen (PH2).







### 7. Til dørtykkelse X: forbered gevindstænger og firkant

- Sav til rådighed.
- Skydelære til rådighed.
- PH2-skruetrækker til rådighed.

- For X: Mål tykkelsen på døren.



- For X: Skru skruerne, gevindbøsningerne og gevindstængerne sammen.  12
- For X: Marker savepunkterne på gevindstængerne og på firkanten.  13
-  14
- For X: Afkort gevindstængerne og firkanten med en egnet sav.  15

## 8. Programmering af beslag

Programmer beslaget før montering. Afhængigt af produktfamilien kan du bruge forskellige programmeringsenheder.



- 
- 16
- 
- 
- 17
- 
- 
- 18



## 9. Monter beslaget

- ✓ Døren er forboret.
- ✓ PH2-skruetrækker til rådighed.
- ✓ TX15-skruetrækker til rådighed.
- ✓ Skydelære til rådighed.
- ✓ Knibetang tilgængelig.

- For S, M og L: Mål dørens tykkelse.  19
- For S, M og L: Bestem skillepunkterne ved afklipningsskruerne.  20
- For S, M og L: Afkort afklipningsskruerne.  21
- For 7 mm firkant: Sæt adaptertyllen på siden af firkanten med en stift.  22  
Sæt firkanten med stiftsiden ind i beslaget.  
 Stiftens klikker ind i holderen.  23
-  24
- Til 8,5 mm, 9 mm og 10 mm firkant: Skub adaptertyllen ind i midten af firkanten. Lav en fordybning i adaptertyllen med en hammer og en kørner for at forhindre, at den glider.  25  
 26
- Sæt det udvendige beslag, evt. med adaptertyller, ind i døren fra ydersiden.  27

Ø monteringshul til indstikslås	Adaptertyller
5,5 mm - 6,3 mm	Ingen adaptertyller
6,4 mm - 7,3 mm	6,4 mm
7,4 mm - 8,7 mm	7,4 mm
≥ 8,8 mm	8,8 mm

- Sæt rosetbasen med tylemøtrikkerne ind døren på ydersiden.  28
- Sæt adapterpladen på døren.  29
- Juster adapterpladen, så firkanten er præcis i midten, og adapterpladen er præcis lodret.  30

11. Skru adapterpladen fast (PH2, drejningsmoment: 1,1 Nm).  31
12. Skru rosetbasen fast på indersiden.  32
13. Indsæt blindcylindere.





### BEMÆRK

#### Før blindcylindere med skruetrækker i hullet

Især ved tykke døre er det svært at placere blindcylindere korrekt.

1. Sæt en skruetrækker ind i hullet i blindcylindere.
2. Placer blindcylindere ved hjælp af skruetrækkeren.

- 
- 33
- 
- 
- 34
- 
- 
- 35

14. Skru blindcylindere fast (PH2, drejningsmoment: 1,1 Nm).
15. Vent fem timer, indtil den skridsikre belægning har sat sig.











### BEMÆRK

#### Hviletid for skridsikker støtte

Den medfølgende adapterplade er udstyret med en skridsikker støtte. Denne kræver en indstillingstid for at få fuld effekt.

1. Efter montering af adapterpladen skal du vente fem timer, før du fortsætter med monteringen.
2. Hvis du er nødt til at færdigmontere tidligere: Tryk ikke håndtaget ind til anslag.

- 
- 36
- 
- 
- 37
- 
- 
- 22
- 
- 
- 39
- 
- 
- 40
- 
- 
- 41
- 
- 
- 42
- 
- 
- 43
- 
- 
- 44
- 
- ➔ Beslaget er færdigmonteret.

## 10. Afmontering af beslag

- ✓ Anvend 1,5 mm unbrakonøgle.
1. Afmonter beslaget i omvendt rækkefølge i forhold til monteringen.
  2. Sæt en 1,5 mm sekskantnøgle ind i hullet på den firkantede holder i beslaget.  45

- Bøj sekskantnøglen til den side, hvor hullet er placeret, og træk samtidig i det udvendige håndtag.



46

- ↳ Beslaget er afmonteret.

## 11. Udskiftning af batterier



### BEMÆRK

#### Funktionsfejl på grund af dårligt kontakt eller anden afladning

For små / forurenede kontaktområder eller forskellige afladede batterier kan føre til funktionsfejl.

- Anvend kun batterier, som er frigivet af SimonsVoss.
- Berør ikke de nye batteriers kontakter med hænderne.
- Anvend rene og fedtfrie handsker.
- Skift derfor altid alle batterier samtidigt.

- ✓ Specialværktøj er tilgængeligt.
- ✓ Handsker til rådighed.

- Sæt specialværktøjet ind i dækslet på beslagsiden.



47

- Tag dækslet af med værktøjet.



48



49

- Bøj forsigtigt batteriklemmen indad for at hægte den af.



50



51

- Åbn batteriklemmen.



52

- Træk batteriklemmen ud.



53

- Tag de gamle batterier ud.



54

- Sæt de nye batterier i med de positive poler i berøring (type CR2450).



55

- Sæt batteriklemmen på igen.



56

- Sæt batteriklipsen på plads igen.



57

- Sæt dækslet tilbage på beslaget.



58

- Klips dækslet fast igen.



59

- ↳ Batterierne er udskiftet.

## 12. Tekniske data

Temperaturområde (drift)	-25 °C til +50 °C
Batteritype	4× CR2450 (3V)
Batteriproducent	<ul style="list-style-type: none"> <li>■ Murata</li> <li>■ Varta</li> <li>■ Panasonic</li> </ul>
IP-kapslingsklasse	IP40

## Radio emissies

15,24 kHz - 72,03 kHz Kun for artikelnumre: SV-S2.*A*, SV-S2.*AM*, SV-S2.*LN*	10 dBµA/m (3 m afstand)
13,560006 MHz - 13,560780 MHz	1,04 dBµA/m (3 m afstand)
868,000 MHz - 868,600 MHz / 869,700 MHz - 870,000 MHz Kun for artikelnumre: SV-S2.*LN*, SI-S2.*M.WO*	<25 mW ERP
2402 MHz - 2480 MHz	2,5 mW

## 13. Overensstemmelseserklæring

Hermed erklærer SimonsVoss Technologies GmbH at varen (SV-S2.\*A\*, SV-S2.\*AM\*, SV-S2.\*LN\*, SI-S2.\*M.WO\*, SI-S2.\*M.VCN\*) overholder følgende retningslinjer:

- 2014/53/EU -RED- eller for Storbritannien: UK lovbekendtgørelse 2017 nr. 1206 -Radioudstyr-
- 2011/65/EU -RoHS- eller for Storbritannien: UK lovbekendtgørelse 2012 nr. 3032 -RoHS-



Den fulde ordlyd af EU-overensstemmelseserklæringen er tilgængelig på følgende internetadresse: [www.simons-voss.com/dk/certifikater.html](http://www.simons-voss.com/dk/certifikater.html). Den fulde ordlyd af UK-overensstemmelseserklæringen er tilgængelig på følgende internetadresse: [www.simons-voss.com/dk/certifikater.html](http://www.simons-voss.com/dk/certifikater.html).

## 14. Hjælp og flere oplysninger

### Infomateriale/dokumenter

<https://www.simons-voss.com/dk/dokumenter.html>

<https://www.smartintego.com/int/home/infocenter/documentation>

### Overensstemmelseserklæringer

<https://www.simons-voss.com/dk/certifikater.html>

### Oplysninger om bortskaffelse

- Enheden (SV-S2.\*A\*, SV-S2.\*AM\*, SV-S2.\*LN\*, SI-S2.\*M.WO\*, SI-S2.\*M.VCN\*) må ikke bortskaffes med husholdningsaffaldet, men skal afleveres på den kommunale affaldsplads, jf. det europæiske direktiv 2012/19/EU.
- Brugte eller defekte batterier skal genanvendes jf. det europæiske direktiv 2006/66/EG.
- Overhold de lokale bestemmelser for separat bortskaffelse af batterier.
- Aflever emballagen til miljørigtig genanvendelse.



60

### e-mail

[support-simonsvoss@allegion.com](mailto:support-simonsvoss@allegion.com)

[si-support-simonsvoss@allegion.com](mailto:si-support-simonsvoss@allegion.com)

SimonsVoss Technologies GmbH, Feringastr. 4, D-85774 Unterföhring, Tyskland

## 1. Avsedd användning

Produkterna i SmartHandle AX-serien gäller elektroniska dörrhandtag. Med hjälp av ett behörigt identifikationsmedium kan man aktivera SmartHandle AX och öppna motsvarande dörr.

Behörigheter måste tilldelas med hjälp av ett elektroniskt låsschema.

Produkterna i SmartHandle AX-serien får bara användas för att öppna och stänga dörrar. Varje annan användning är förbjuden.

## 2. Allmänna säkerhetsanvisningar

*Signalord: Eventuella omedelbara effekter av bristande efterlevnad*

**VARNING:** Död eller allvarlig skada (möjligt, men osannolikt), **OBSERVERA:** Liten skada, OBS: Skador på egendom eller fel, INFO: Låg eller ingen



### VARNING

#### Tillgång spärrad

Felaktigt installerade och/eller programmerade komponenter kan leda till att dörrar spärras. SimonsVoss Technologies GmbH ansvarar inte för konsekvenserna av felaktig installation såsom spärrat tillträde till skadade personer eller personer i risksituationer, materiella skador eller andra typer av skador.

#### Blockerad åtkomst genom manipulering av produkten

Om du ändrar produkten på egen hand kan fel uppstå och åtkomst via en dörr kan blockeras.

- Ändra endast produkten vid behov och endast på det sätt som beskrivs i dokumentationen.

#### Svälj inte batteriet. Risk för brännskador på grund av farliga ämnen.

Den här produkten innehåller litiumknappcells-batterier. Om man råkar svälja ett knappcells-batteri kan allvarliga inre brännskador uppstå inom bara två timmar vilket i sin tur kan leda till döden.

- Förvara nya och förbrukade batterier utom räckhåll för barn.
- Upphör att använda produkten och förvara den utom räckhåll för barn om batterilocket inte går att stänga ordentligt.
- Uppsök omedelbart läkare om du misstänker att batterier har svalts eller befinner sig i någon kroppsdels.

#### Explosionsrisk på grund av felaktigt batterityp

Att sätta i fel typ av batteri kan leda till en explosion.

- Använd endast de batterier som anges i de tekniska data.



### OBSERVERA

#### Brandrisk som utgår från batterier

De isatta batterierna kan orsaka brand eller brännskador om de hanteras på ett felaktigt sätt.

- Försök inte att ladda upp, öppna eller värma upp batterierna.
- Kortslut inte batterierna.

### OBS

#### Skador på grund av elektrostatiske urladdning (ESD) när hölet är öppet

Den här produkten innehåller elektroniska komponenter som kan skadas av elektrostatiske urladdningar.

- Använd alltid ESD-anpassat arbetsmaterial (t.ex. jordningsarmband).
- Jorda dig före alla arbeten där du kan komma i kontakt med elektronik. Det gör du genom att fatta tag i en jordad metallta (såsom dörrkarmar, vattenrör eller värmeventiler).

#### Skada på grund av vätskor

Den här produkten innehåller elektroniska och/eller mekaniska komponenter som kan skadas av alla typer av vätskor.

- Låt inte elektroniken komma i kontakt med vätskor.

#### Skada på grund av aggressiva rengöringsmedel

Ytan på den här produkten kan skadas om olämpliga rengöringsmedel används.

- Använd endast rengöringsmedel som lämpar sig för plast- och metall-typer.

#### Skada på grund av mekanisk påverkan

Den här produkten innehåller elektroniska komponenter som kan skadas av alla typer av mekanisk påverkan.

- Undvik att vidröra elektroniken.
- Undvik annan mekanisk påverkan på elektroniken.

#### Skada på grund av polvändning

Den här produkten innehåller elektroniska komponenter som kan skadas på grund av polvändning i spänningskällan.

- Vänd inte spänningskällans poler (batterier resp. nätdelar).

#### Driftstörning på grund av radiostörning

Den här produkten kan i vissa fall påverkas av elektromagnetiska eller magnetiska störningar.

- Produkten ska inte monteras eller placeras i omedelbar närhet av utrustning som kan orsaka elektromagnetiska eller magnetiska störningar (switchade nättaggregat!).

#### Kommunikationsstörning på grund av metallytor

Den här produkten kommunicerar trådlöst. Metallytor kan minska produktens räckvidd avsevärt.

- Produkten ska inte monteras eller placeras på eller i närheten av metallytor.



### INFO

#### Avsedd användning

SimonsVoss-produkter är uteslutande avsedda för öppning och stängning av dörrar och liknande.

- Använd inte SimonsVoss-produkter för andra syften.

#### Funktionsstörningar på grund av dålig dålig kontakt eller annan urladdning

För små / kontaminerade kontaktytor eller olika urladdade batterier kan leda till funktionsstörningar.

- Används endast batterier som är godkända av SimonsVoss.
- Vidrör inte de nya batteriernas kontakter med händerna.
- Använd rena och fettfria handskar.
- Byt alltid alla batterier samtidigt.

#### Avvikande tider vid G2-lås

G2-låsens interna tidsenhet har en tekniskt betingad tolerans på upp till  $\pm 15$  minuter per år.

#### Kvalifikationer krävs

Installation och idrifttagning kräver specialiserad kunskap.

- Endast utbildad personal får installera och driftsätta produkten.

Ändringar eller teknisk vidareutveckling kan inte uteslutas och kan komma att genomföras utan föregående meddelande om detta.

Den tyska språkversionen är den ursprungliga bruksanvisningen. Andra språk (utarbetade på kontraktsspråket) är översättningar av originalinstruktionerna.

Läs och följ alla installations-, installations- och driftsinstruktioner. Skicka dessa instruktioner och alla underhållsinstruktioner till användaren.

## 3. Produktspecifika säkerhetsanvisningar

### OBS

#### Skada vid borring

De borrar på egen risk. För skador orsakade av borring är SimonsVoss Technologies GmbH inte ansvarigt. Sie bohren auf eigene Gefahr.

- Beakta också borrhens säkerhetsinstruktioner.

### Skador på grund av olämpligt verktyg

Att försöka öppna ärendet med ett felaktigt verktyg kan skada fallet.

- Använd endast det medföljande SimonsVoss-öppningsverktyget.

### Förlost av exakt handtagsstyrning

Hos instickslåås med klämhylsa kan monteringen vara trög.

- Bearbeta inte klämhylsan mekaniskt. Handtaget förlorar då sin exakta styrning.

### Försvårad montering på grund av oprecisa hål

Handtaget kan inte monteras om monteringshålen och fyrkanten inte passar ihop.

- Kontrollera att monteringshålens och fyrkantens linjer är parallella vertikalt.



#### INFO

### Aktiv- och hybridteknik med förkortad räckvidd

Den aktiva tekniken och hybridtekniken har en betydligt större räckvidd. I normaldrift nås båda SmartHandle AX samtidigt och kommunikationsfel kan uppstå.

- Markera kryssrutan i LSM/AXM för båda sidorna på SmartHandle AX för kortare räckvidd.

### Påverkan på låsningen

SmartHandle AX fungerar uteslutande på spärrlåset.

### Försäkringslagstiftning

Försäkringsbolag ställer större krav på stängning.

- Om du vill stänga dörren enligt försäkringslagarna, använd ett självlåsande paniklås eller en låscylinder utöver SmartHandle AX.
- Var uppmärksam på godkännandena enligt EN 179.

### SmartHandle AX med självlåsande paniklås

SmartHandle AX erbjuder full funktionalitet endast med ett självlåsande paniklås.

- Kombinera SmartHandle AX med ett självlåsande paniklås.
- Var uppmärksam på förklaringarna om överensstämmelse hos låsetillverkaren enligt EN 179.

### Villkor för säkerhet i samband med tillstånd

Drift med Mifare Classic- och/eller PinCode-tangentbord utesluter behörighetssäkerhetsklass D enligt DIN EN 16867:2020.

### Färluta rosettoppning

En rosettoppning kan utnyttjas för manipulation.

- Färluta eventuella rosettoppningar med exempelvis en blindcylinder.
- För FH-varianter: Montera ovillkorligen en blind- eller låscylinder av mässing.

### Vilotid för glidhämmande yta

Den medföljande adapterplattan är försedd med en glidhämmande yta. Den behöver tid att sätta sig för att få full effekt.

- Vänta i fem timmar efter montering av adapterplattan innan du fortsätter monteringen.
- Om du måste montera färdigt: Manövrera inte handtaget till anslag.

## 4. Leveransomfång

- SmartHandle AX (För montering på båda sidor, bestående av adapterplattor och innerdel. Den stående SmartHandle AX för ytterdelen medföljer inte.)

- Specialverktyg

- Snabbguide

Beroende på variant:







- Adaptersats 7 mm-fyrkant
- Adapterhylsa 8,5 mm-fyrkant
- Adapterhylsa 9 mm-fyrkant
- Adapterhylsa 10 mm-fyrkant

## 5. Uppbyggnad





## 6. Förbereda dörr (borrschablon)

- ✓ Stift eller itsnål finns.
- ✓ Borrmaskin finns.
- ✓ Lämplig borr finns (beroende på instickslåsets håldiameter: 8,5 mm / 9,5 mm / 10,5 mm).
- ✓ PH2-skruvmejsel finns.





- Stick in fyrkanten i instickslåset. 
- Sätt på borrschablonen på fyrkanten. 
- Rikta in borrschablonen lodrätt med hjälp av den påtryckta skalan. 
- Avlägsna borrschablonen. 
- Avlägsna fyrkanten. 
- Demontera instickslåset (PH2). 
- Mät fästhålens diameter. 

Ø fästhål	Borr som behövs
5,5 mm–6,3 mm	8,5 mm
6,4 mm–7,3 mm	8,5 mm
7,4 mm–8,7 mm	9,5 mm
≥ 8,8 mm	10,5 mm

- Avgör vilken borr som ska användas utifrån den uppmätta diametern.
- Borra de hål som behövs. 
- Montera instickslåset (PH2). 

## 7. För dörrtjocklek X: Förbereda gångstänger och fyrkant

- ✓ Såg finns.
- ✓ Skjutmått finns.
- ✓ PH2-skruvmejsel finns.

- För X: Mät dörrtjockleken. 
- För X: Skruva samman skruvarna, gänghylsorna och gångstängerna. 
- För X: Markera sågställena på gångstängerna och fyrkanten. 
- För X: Korta av gångstängerna och fyrkanten med en lämplig såg. 
- 

## 8. Programmera handtag

Programmera handtaget före montering. Beroende på produktfamilj kan du använda olika programmeringsenheter.



16



17



18

## 9. Montera handtag

- ✓ Dörr förborrad.
- ✓ PH2-skruvmejsel finns.
- ✓ TX15-skruvmejsel finns.
- ✓ Skjutmått finns.
- ✓ Kniptång finns.

1. För S, M och L: Mät dörrtjockleken.



19

2. För S, M och L: Bestäm var skruvarna ska kapas.



20

3. För S, M och L: Korta skruvarna.



21

4. För 7 mm-fyrkant: Sätt på adapterhylsan på fyrkantens sida med stift.



22

5. Stick in fyrkanten med stiftsidan i handtaget.

↳ Stiftet snäpper fast i fästet.



23



24

6. För 8,5 mm- 9 mm- och 10 mm-fyrkant: Skjut in adapterhylsan i mitten av fyrkanten. Gör en fördjupning i adapterhylsan med en kornare och hammare för att förhindra att den glider.



25



26

7. Sätt in ytterhandtaget, i förekommande fall med adapterhylsor, i dörren från utsidan.



27

Ø fasthåll instickslås	Adapterhylsor
5,5 mm–6,3 mm	Inga adapterhylsor
6,4 mm–7,3 mm	6,4 mm
7,4 mm–8,7 mm	7,4 mm
≥ 8,8 mm	8,8 mm

8. Sätt i rosettbasen med hylsmuttrarna i dörren från utsidan.



28

9. Lägg adapterplattan mot dörren.



29

10. Rikta in adapterplattan så att fyrkanten är exakt i mitten och adapterplattan är helt lodrät.



30

11. Skruva fast adapterplattan (PH2, åtdragningsmoment: 1,1 Nm).



31

12. Skruva fast rosettbasen med på insidan.



32

13. Sätt in blindcylindern.



### INFO

#### För in blindcylindern i hålet med skruvmejseln.

Särskilt om dörrarna är tjocka är det svårt att positionera blindcylindern korrekt.

1. Sätt in en skruvmejseln i hålet för blindcylindern.
2. Positionera blindcylindern med hjälp av skruvmejseln.



33



34

14. Skruva fast blindcylindern (PH2, åtdragningsmoment: 1,1 Nm).



35

15. Vänta i fem timmar tills antiglidytan har satt sig.



### INFO

#### Vilodid för glidhämmande yta

Den medföljande adapterplattan är försedd med en glidhämmande yta. Den behöver tid att sätta sig för att få full effekt.

1. Vänta i fem timmar efter montering av adapterplattan innan du fortsätter monteringen.
2. Om du måste montera färdigt: Manövrera inte handtaget till anslag.



36

16. Avlägsna kåpan med verktyget.



37

17. För 7 mm-fyrkant: Sätt på adapterhylsan på fyrkanten.



22

18. Skjut in beslaget i adapterplattan.



39

19. Vrid handtaget rakt.



40

20. Skruva fast handtaget på adapterplattan för att förhindra vridning.



41

21. Sätt kåpan på modulen.



42

22. Sätt på ytterhandtagen på handtagen.

23. Sätt på skydden på rosettbaserna.



43

24. Skruva fast de båda handtagens stoppskruvar (TX15, åtdragningsmoment: 5,0 Nm).



44

↳ Handtaget är färdigmonterat.

## 10. Demontera handtag

- ✓ 1,5 mm sexkantnyckel finns.

1. Demontera handtaget i omvänd ordningsföljd jämfört med montering.
2. Sätt in en 1,5 mm-insexnyckel i hålet på fyrkantsfästet i handtaget.



45

3. Böj insexnyckeln åt den sida där hålet sitter och dra samtidigt i ytterhandtaget.



46

↳ Handtaget är demonterat.

## 11. Byt batterier.



### INFO

Funktionsstörningar på grund av dålig dålig kontakt eller annan urladdning

För små / kontaminerade kontaktytor eller olika urladdade batterier kan leda till funktionsstörningar.

1. Används endast batterier som är godkända av SimonsVoss.
2. Vidör inte de nya batteriernas kontakter med händerna.
3. Använd rena och fettfria handskar.
4. Byt alltid alla batterier samtidigt.

- ✓ Specialverktyg finns.
- ✓ Handskar finns.

1. Sätt i specialverktyget i kåpinlägget på handtaget.



2. Avlägsna kåpan med verktyget.



3. Böj batteriklämman försiktigt inåt för att haka ur den.



4. Öppna batteriklämman.



5. Dra ut batteriklämman.



6. Ta ur de gamla batterierna.



7. Sätt i de nya batterierna så att pluspolerna vidrör varandra (typ CR2450).



8. Sätt tillbaka batteriklämman igen.



9. Haka i batteriklämmorna igen.



10. Sätt tillbaka kåpan på handtaget.



11. Knäpp fast kåpan igen.



- ↳ Batterierna är bytta.

## 12. Tekniska data

Temperaturområde (drift)	-25 °C till +50 °C
Batterityp	4 × CR2450 (3V)
Batteritillverkare	<ul style="list-style-type: none"> <li>■ Murata</li> <li>■ Varta</li> <li>■ Panasonic</li> </ul>
IP-kapslingsklass	IP40

### Utsläpp radio

15,24 kHz - 72,03 kHz Endast för artikelnummer: SV-S2.*A*, SV-S2.*AM*, SV-S2.*LN*	10 dBµA/m (3 m avstånd)
13,560006 MHz - 13,560780 MHz	1,04 dBµA/m (3 m avstånd)

868,000 MHz - 868,600 MHz / 869,700 MHz - 870,000 MHz Endast för artikelnummer: SV-S2.*LN*, SI-S2.*M.WO*	<25 mW ERP
2402 MHz - 2480 MHz	2,5 mW

## 13. Försäkran om överensstämmelse

Häriförklarar SimonsVoss Technologies GmbH att varan (SV-S2.\*A\*, SV-S2.\*AM\*, SV-S2.\*LN\*, SI-S2.\*M.WO\*, SI-S2.\*M.VCN\*) uppfyller följande riktlinjer:

- 2014/53/EU -RED- eller för Storbritannien: Förenade kungarikets lag 2017 nr 1206 -Radoustruning-
- 2011/65/EU -RoHS- eller för Storbritannien: Förenade kungarikets lag 2012 nr 3032 -RoHS-



Den fullständiga texten till EU-försäkran om överensstämmelse finns på följande internetadress: [www.simons-voss.com/se/certifikat.html](http://www.simons-voss.com/se/certifikat.html).

Den fullständiga texten till UK-försäkran om överensstämmelse finns på följande internetadress: [www.simons-voss.com/se/certifikat.html](http://www.simons-voss.com/se/certifikat.html).

## 14. Hjälp och ytterligare information

### Infomaterial/dokument

<https://www.simons-voss.com/se/dokument.html>

<https://www.smartintego.com/int/home/infocenter/documentation>

### Försäkringar om överensstämmelse

<https://www.simons-voss.com/se/certifikat.html>

### Informationen är öppen

- Produkten (SV-S2.\*A\*, SV-S2.\*AM\*, SV-S2.\*LN\*, SI-S2.\*M.WO\*, SI-S2.\*M.VCN\*) får inte slängas i hushållsoporna utan ska lämnas in på en kommunal uppsamlingsplats för elektriskt och elektroniskt avfall i enlighet med direktiv 2012/19/EU.
- Defekta eller uttjänta batterier ska återvinnas i enlighet med direktiv 2006/66/EG.
- Beakta gällande lokala bestämmelser gällande separat bortskaftande av batterier.
- Avfallshanterta förpackningsmaterial på ett miljövänligt sätt.



[support-simonsvoss@allegion.com](mailto:support-simonsvoss@allegion.com)

[si-support-simonsvoss@allegion.com](mailto:si-support-simonsvoss@allegion.com)

SimonsVoss Technologies GmbH, Feringastr. 4, D-85774 Unterföhring, Tyskland

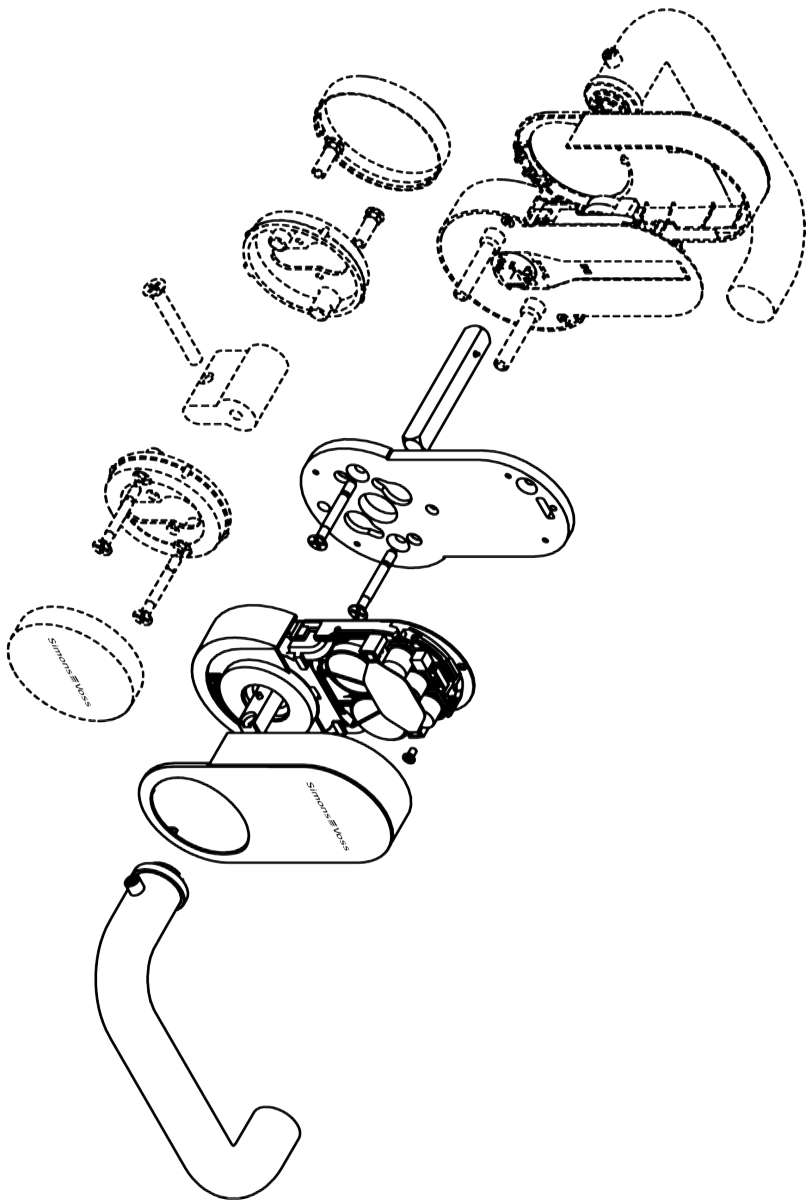

© 2024, SimonsVoss Technologies GmbH, Unterföhring

All rights are reserved. Text, images and diagrams are protected under copyright law.

The content of this document must not be copied, distributed or modified. You can find more information on our website. Subject to technical changes.

SimonsVoss and MobileKey are registered brands belonging to SimonsVoss.

**SimonsVoss**  
technologies

Made in Germany

A BRAND OF

  
**ALLEGION**