



## SOFTWARE

### LSM BASIC EDITION.

- :: FREELY PROGRAMMABLE
- :: ISSUE AUTHORISATIONS AT THE CLICK OF YOUR MOUSE
- :: ACCESS CONTROL, TIME ZONE MANAGEMENT AND LOGGING

### LSM BUSINESS EDITION. LSM PROFESSIONAL EDITION.

- :: BASED ON A DATABASE
- :: MULTI-USER- AND MULTI-CLIENT-ENABLED
- :: OPEN INTERFACES

# SOFTWARE FOR THE EFFECTIVE USE OF INTELLIGENT SYSTEM COMPONENTS

## OVERVIEW.

Intelligent components form the core of the Digital Locking and Access Control System. The software is the unifying element that enables all tasks to be implemented quickly and conveniently. Issue transponders to new members of staff, program the locking cylinders with current authorisations and view access instances over the network.

The more complex the requirements, the more sophisticated the software needs to be. To deal with standard tasks, all you need is one simple piece of software. A large group of companies with offices all over the world needs a package that offers high performance.

System 3060 allows you to choose the right software from a range of different solutions. Individual versions are all compatible, ensuring future requirements will be met.

## FOR SYSTEMS LARGE AND SMALL.

Very small systems, particularly those used privately, can be configured quickly and cost-effectively without the need for a PC or special software by using the programming transponder 3067.

For all other systems, the Locking System Management (LSM) software is used. The software is made up of editions and modules to meet your needs, and grows to meet your changing requirements. In small to medium-sized systems, the LSM Basic Edition is sufficient to manage locking plans with ease. You can upgrade from basic locking plan software to administration software with the LSM "Business" and "Professional" editions: database-based, multi-user- and multi-client-enabled and with an integrated reporting function. In access control systems with several locations, using a WaveNet Radio Network simplifies administrative work and has a considerable cost benefit.

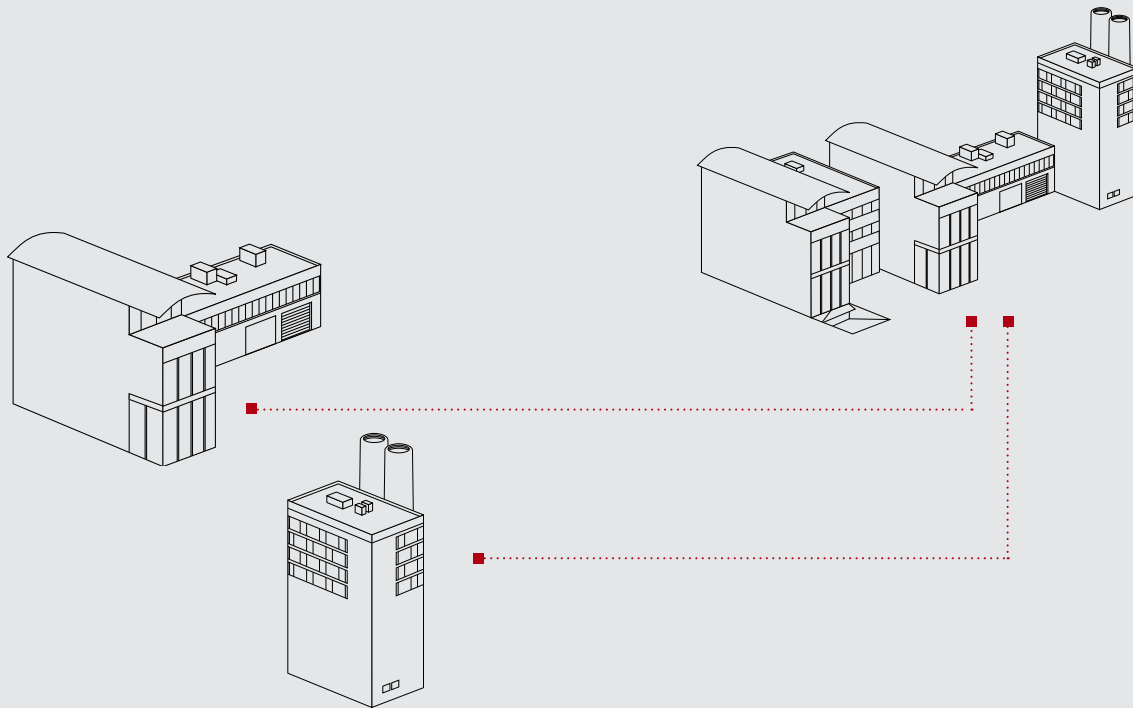

## BASIC STRUCTURE.

- ⚡ LSM provides a basic data structure which grows with the size of your system. There are various components and modules which enhance and extend the existing installation by adding new functions and increasing performance.
- ⚡ The database engine: A renowned database server, which is simple to install and creates no additional administrative work, forms the basis of LSM Business Edition. It guarantees data security and the stability and performance of the program.
- ⚡ Communication nodes establish connections to existing programming devices and networks. They process tasks and events.
- ⚡ The user program with a graphical user interface (GUI) is installed on all clients. The graphical user interface allows you to view and edit the structures of the locking plan in different views, compressed or in detail.

## INTERFACES.

- ⚡ Database for read access
- ⚡ Interfaces to the PDA database and to the EventAgent
- ⚡ Messaging interface for sending text messages and e-mails
- ⚡ ASCII interface
- ⚡ LDAP interface for import
- ⚡ Software Interface Kit (SIK) for exchanging data with third-party systems (details on request)

# LSM EDITIONS AND MODULES OVERVIEWS

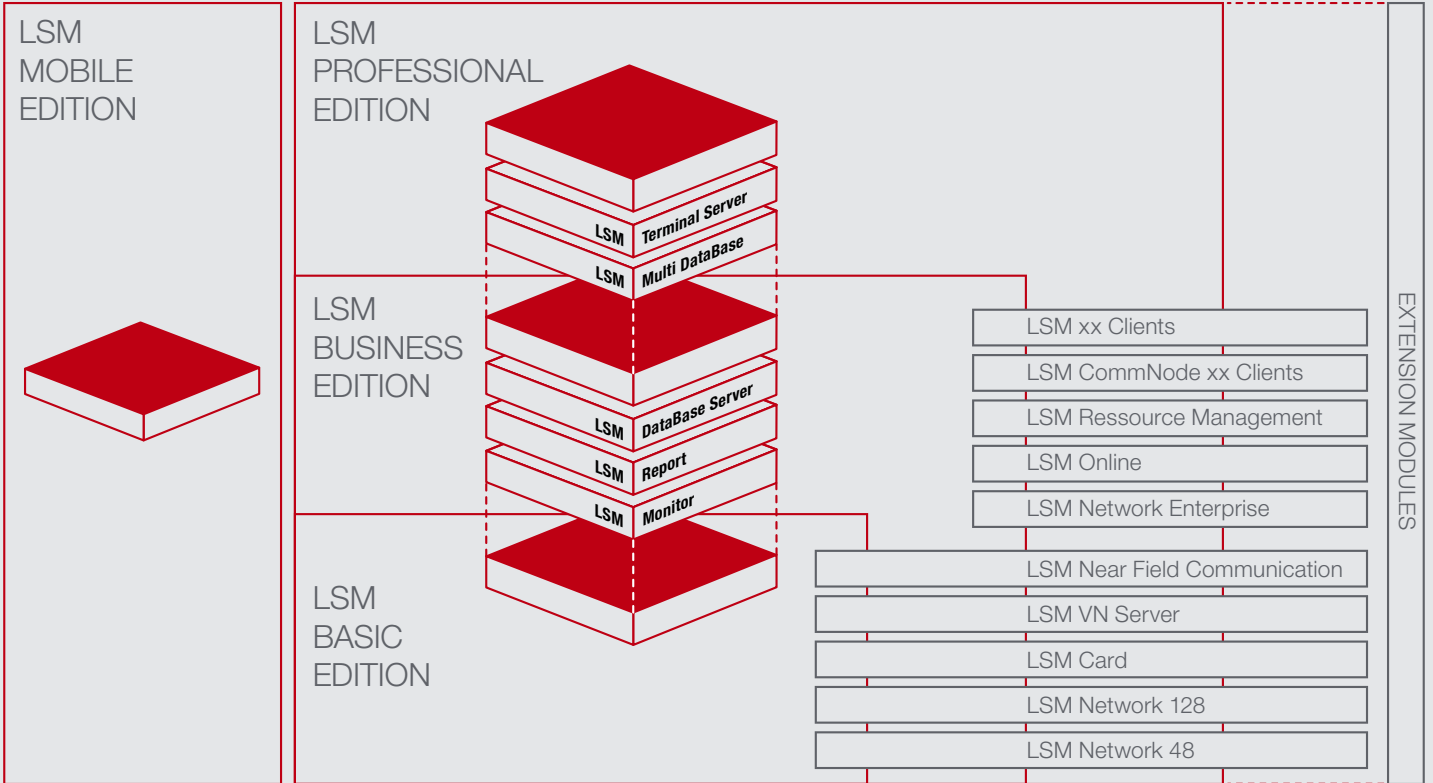

LSM  
EDITIONS AND MODULES  
OVERVIEWS

LSM MODULE	LSM EDITIONS			LSM DEMO VERSIONS	
	Basic	Business	Professional	Basic	Business
LSM Basic Functionality	•	•	•	•	•
LSM Monitor	◦	•	•	•	•
LSM Report	◦	•	•	•	•
LSM DataBase Server	◦	•	•	X	•
LSM Network 48	◦	◦	◦	X	•
LSM Network 128	◦	◦	◦	X	•
LSM Network Enterprise	X	◦	◦	X	•
LSM Card	◦	◦	◦	X	•
LSM Near Field Communication	•	•	•	•	•
LSM VN Server	◦	◦	◦	X	•
LSM Online	X	◦	◦	X	•
LSM Ressource Management	X	◦	◦	X	•
LSM CommNode 05 Clients	X	◦	◦	X	X
LSM CommNode 10 Clients	X	◦	◦	X	X
LSM CommNode Enterprise	X	◦	◦	X	X
LSM Multi DataBase	X	◦	•	X	X
LSM Terminal Server	X	◦	•	X	X
LSM 03 Clients	X	◦	◦	X	X
LSM 05 Clients	X	◦	◦	X	X
LSM 10 Clients	X	◦	◦	X	X
LSM 25 Clients	X	◦	◦	X	X
LSM 50 Clients	X	◦	◦	X	X
Additional clients on request					
LSM Mobile Edition	◦	◦	◦	X	X

• included ◦ available as option X not available

# LSM CONCEPTS AND TOPOLOGIES

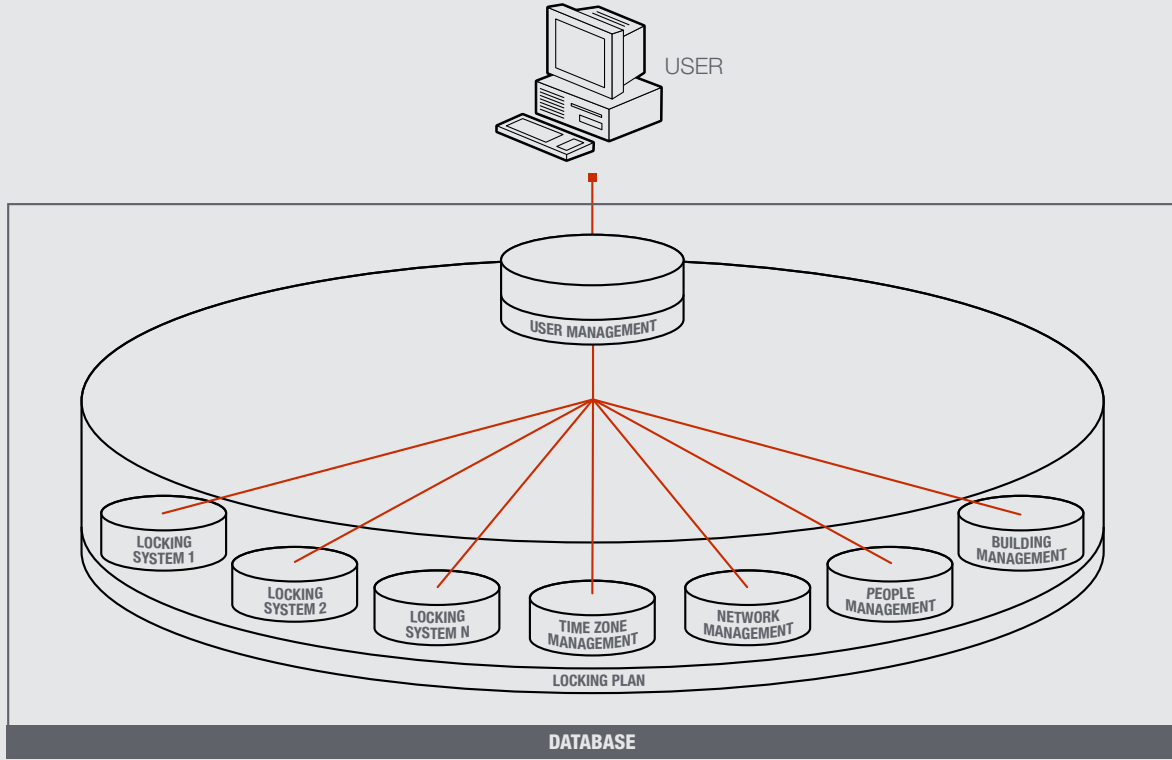

LSM BASIC EDITION

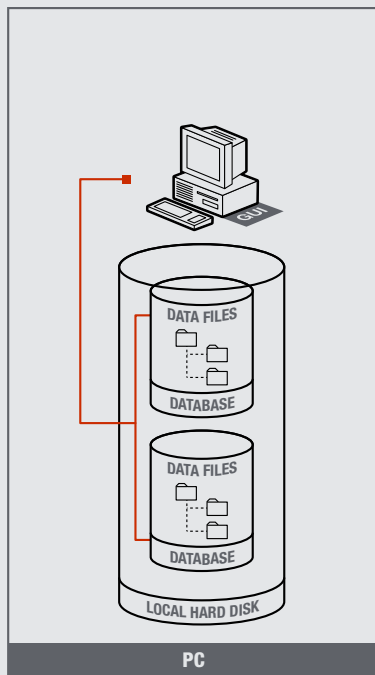

LSM BUSINESS EDITION

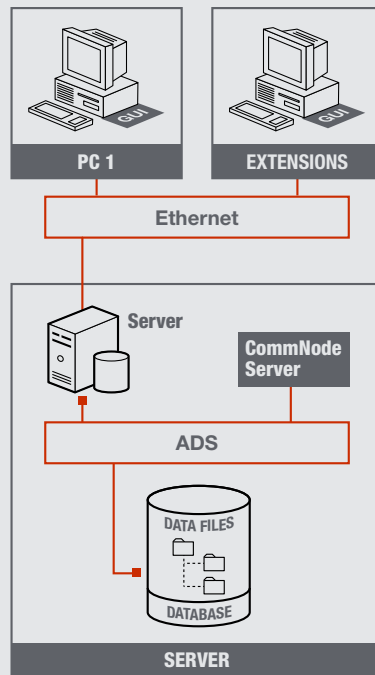

LSM PROFESSIONAL EDITION

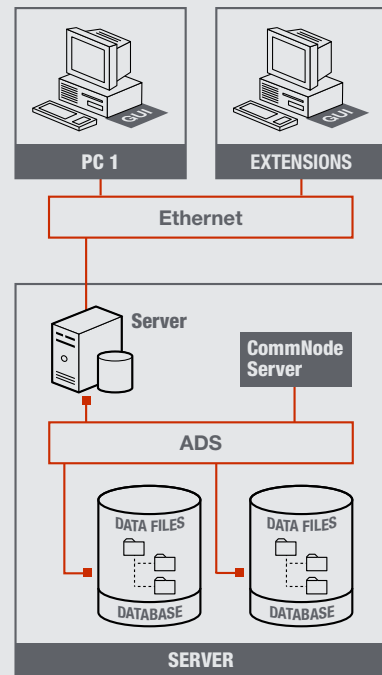

GUI: graphical user interface  
ADS: Advantage Database Server

# LSM SOFTWARE EDITIONS



## LSM BASIC EDITION.

Single-user version, no network administration, local installation of software and data on one computer

- ⌘ G1 locking systems  
(8,000 transponders, 16,000 locks, 5+1 time zones)
- ⌘ G2 locking systems  
(64,000 transponders, 64,000 locks, 100 time zones)

Functions:

- ⌘ Transponder groups
- ⌘ Areas for mapping building and organisational structures (first level)
- ⌘ Use of multiple locking systems
- ⌘ Transfer of existing locking plans (import)
- ⌘ Data exchange with mobile terminal devices (PDA)
- ⌘ Basis for further system expansion

## LSM BUSINESS EDITION.

Same functionality as LSM Basic, includes modules Monitor (logging, audit-compliant), Report and DataBase

## LSM PROFESSIONAL EDITION.

Same functionality as LSM Business, extended through additional option of using several databases on the server and for operating in a terminal server environment

## LSM MOBILE EDITION.

For programming with a mobile terminal device (PDA or netbook)

## SERVICE LEVEL AGREEMENT STANDARD AND PREMIUM.

Modern software solutions offer a whole range of functions that make everyday life simpler. But even with intensive training and day-to-day experience of using the software, issues can still crop up. You are guaranteed a quick solution with our various support levels (Service Level Agreement – SLA). With “SLA Standard” you receive telephone user support for LSM. If you conclude an “SLA Premium” contract, you will receive additional online support and automatic LSM software updates. One of these service level agreements must be concluded for LSM.BUSINESS and LSM.PROFESSIONAL.

# LSM BASIC EDITION MODULES

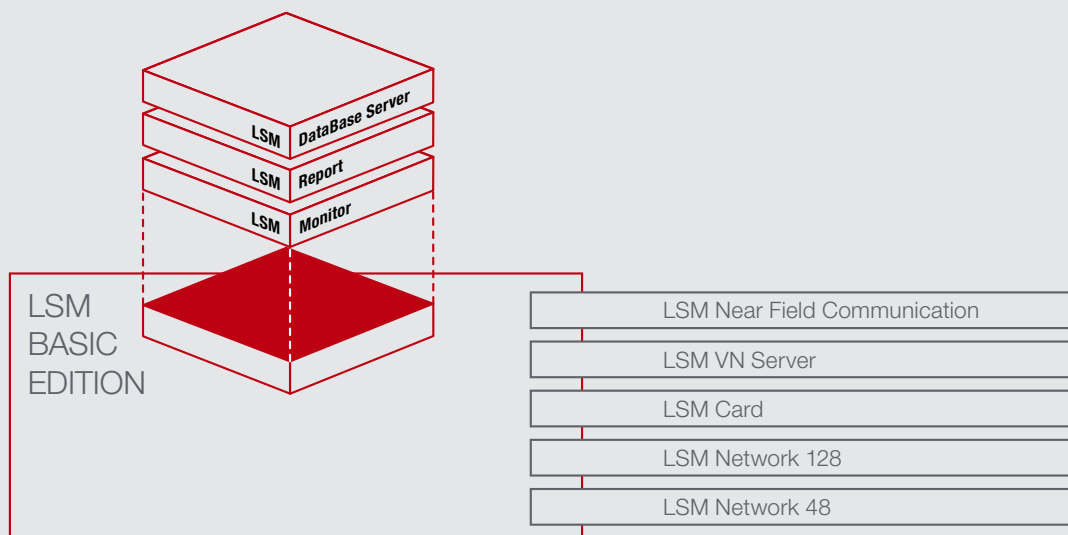

## MODULES FOR LSM BASIC EDITION.

The following additional modules can be ordered for LSM Basic Edition:

- ⌘ LSM NETWORK 48:  
Network functionality for a maximum of 48 networked components
- ⌘ LSM NETWORK 128:  
Network functionality for a maximum of 128 networked components
- ⌘ LSM CARD:  
Card management for the use of passive media:  
MIFARE® Classic in G1 locking systems  
MIFARE® Classic and MIFARE® DESFire in G2 locking systems
- ⌘ LSM VN SERVER:  
Virtual network, automatic distribution of authorisation information to the G2 system via gateways and transponders for simple administration of the SimonsVoss system
- ⌘ LSM NEAR FIELD COMMUNICATION:  
For extension with NFC technology in connection with a smartphone

## EXTENSION MODULES.

- ⌘ LSM MONITOR:  
Logging of system changes in the software (audit compliance)
- ⌘ LSM REPORT:  
Extensive reporting function for viewing locking system information, e.g. transponder issue log, authorisation list per transponder or lock
- ⌘ LSM DATABASE SERVER:  
Database server, hierarchical view and inheritance of authorisations, user roles, network capability for a customer LAN, client-server operation, multi-user capability (simultaneous access), communication nodes on other computers

# LSM BUSINESS EDITION MODULE

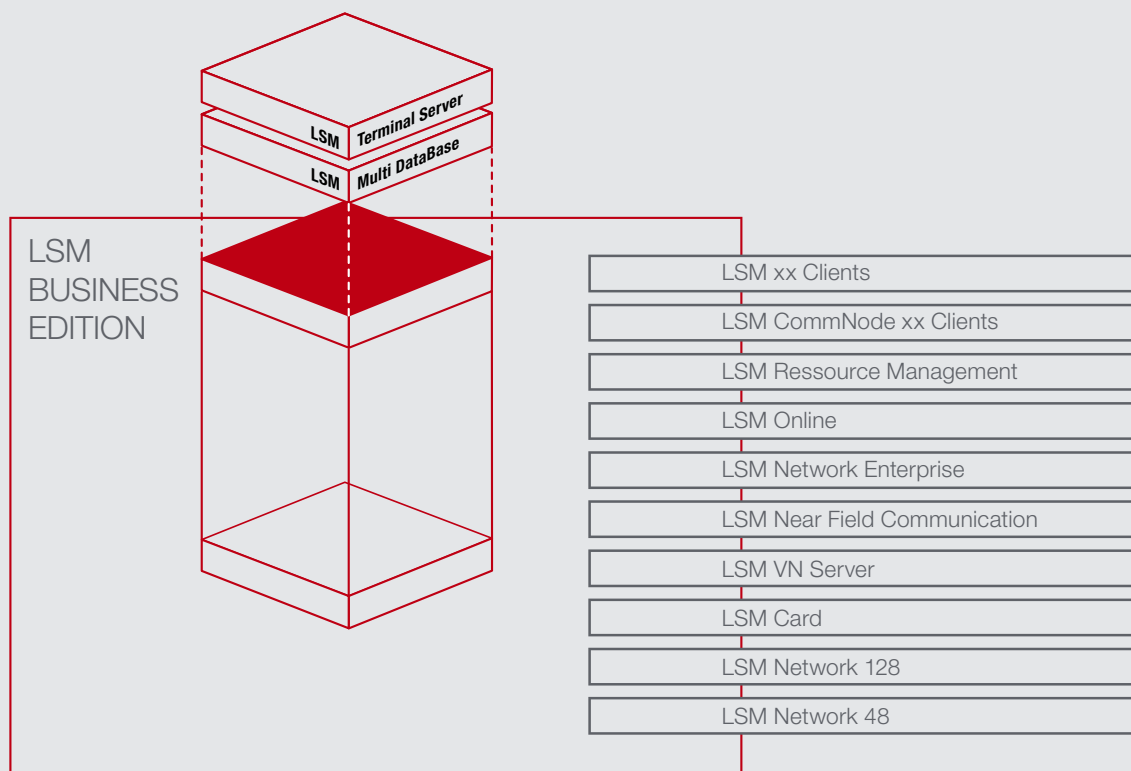

## MODULES FOR LSM BUSINESS EDITION.

Same functionality as LSM Basic Edition.

Includes modules LSM Monitor, LSM Report and LSM DataBase Server. An SLA must be concluded. The following extension modules can also be ordered:

- ⚡ LSM NETWORK 48/128:  
Network functionality for a maximum of 48 or 128 networked components
- ⚡ LSM CARD:  
Card management for the use of passive media:  
MIFARE® Classic in G1 locking systems  
MIFARE® Classic and MIFARE® DESFire in G2 locking systems
- ⚡ LSM VN SERVER:  
Virtual network, automatic distribution of authorisation information to the G2 system via gateways and transponders for simple administration of the SimonsVoss system
- ⚡ LSM NEAR FIELD COMMUNICATION:  
For extension with NFC technology in connection with a smartphone
- ⚡ LSM NETWORK ENTERPRISE:  
Network functionality for any number of networked components
- ⚡ LSM ONLINE:  
Only in combination with one of the network modules  
LSM.NW-xx, task management, alert management, event

management, access to SimonsVoss EventAgent, text messaging functionality, e-mail functionality. The LSM Online module is required in order to use network functions at all workplaces

- ⚡ LSM RESOURCE MANAGEMENT:  
Time restriction on authorisations. Prerequisite: LSM ONLINE
- ⚡ LSM COMMNODE XX CLIENTS/LSM COMMNODE ENTERPRISE:  
Access to SimonsVoss network from up to 5/10 computers or from an unlimited number of computers without graphical user interface (GUI) using additional software
- ⚡ LSM 03 CLIENTS:  
First extension of the database licence to include 3 more workstation installations to a total of 4 workstations
- ⚡ LSM XX CLIENTS:  
Extension of the database licence to include 5/10/25 or 50 more workstations, prerequisite: LSM 03 Clients

## EXTENSION MODULES

- ⚡ LSM MULTI DATABASE:  
Use of several different LSM databases
- ⚡ LSM TERMINAL SERVER:  
Use of LSM in a terminal server environment

# LSM PROFESSIONAL EDITION MODULES

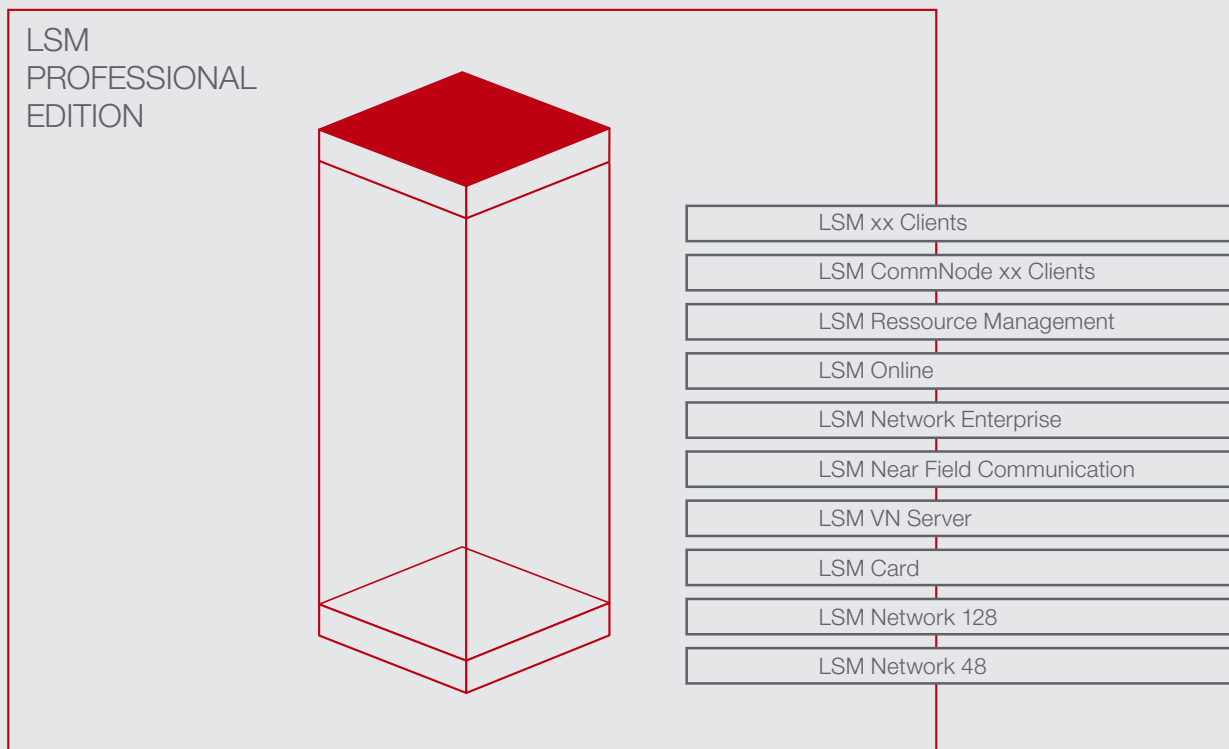

## MODULES FOR LSM PROFESSIONAL EDITION.

Same functionality as LSM Business Edition.

Includes modules LSM Terminal Server and LSM Multi DataBase. An SLA must be concluded. The following extension modules can also be ordered:

- ⚡ LSM NETWORK 48/128:  
Network functionality for a maximum of 48 or 128 networked components
- ⚡ LSM CARD:  
Card management for the use of passive media:  
MIFARE® Classic in G1 locking systems  
MIFARE® Classic and MIFARE® DESFire in G2 locking systems
- ⚡ LSM VN SERVER:  
Virtual network, automatic distribution of authorisation information to the G2 system via gateways and transponders for simple administration of the SimonsVoss system
- ⚡ LSM NEAR FIELD COMMUNICATION:  
For extension with NFC technology in connection with a smartphone
- ⚡ LSM NETWORK ENTERPRISE:  
Network functionality for any number of networked components
- ⚡ LSM ONLINE:  
Only in combination with one of the network modules LSM.NW-XX, task management, alert management, event management, access to SimonsVoss EventAgent, text messaging functionality, e-mail functionality. The LSM Online module is required in order to use network functions at all workplaces
- ⚡ LSM RESOURCE MANAGEMENT:  
Time restriction on authorisations. Prerequisite: LSM ONLINE
- ⚡ LSM COMMNODE XX CLIENTS/LSM COMMNODE ENTERPRISE:  
Access to SimonsVoss network from up to 5/10 computes or from an unlimited number of computers without graphical user interface (GUI) using additional software
- ⚡ LSM 03 CLIENTS:  
First extension of the database licence to include 3 more workstation installations to a total of 4 workstations
- ⚡ LSM XX CLIENTS:  
Extension of the database licence to include 5/10/25 or 50 more workstations, prerequisite LSM 03 Clients

# LSM SOFTWARE EDITIONS AND MODULES

## PRODUCT VERSIONS.

### SOFTWARE EDITIONS

Software LSM Basic Edition for installation on a PC/laptop (please note system requirements)	LSM.BASIC
Software LSM Business Edition for installation on a PC/laptop (please note system requirements)	LSM.BUSINESS
Software LSM Professional Edition for installation on a PC/laptop (please note system requirements)	LSM. PROFESSIONAL
Software LSM Mobile Edition for installation on a mobile terminal device (please note system requirements)	LSM.MOBILE

### SOFTWARE MODULES FOR LSM BASIC

LSM Card module Module to add card management functionality for the use of SmartCard products	LSM.CARD
LSM Monitor module Module to log system changes in the software (audit compliance)	LSM.MONITOR
LSM Report module Module to add extensive reporting	LSM.REPORT
LSM Network 48 module Module to extend network functionality for a maximum of 48 networked components	LSM.NW-48
LSM Network 128 module Module to extend network functionality for a maximum of 128 networked components	LSM.NW-128
LSM VN Server module Module to add G2 "virtual networking" functionality, automatic distribution of authorisation information to the G2 system via gateways and transponders for simple administration of the SimonsVoss system. Hardware and software components must support G2	LSM.VN
LSM Near Field Communication module For extension with NFC technology in connection with a smartphone	LSM.NFC
LSM DataBase Server module Installation of the GUI at one workplace (PC/laptop), client-server operation, includes CommNode Server, multi-user capability, multi-client capability, user roles, functions: transponder groups and areas to represent building and organisational structures, use of several locking systems, data exchange with mobile terminal devices (PDAs/netbooks), prerequisite are modules LSM.MONITOR and LSM.REPORT, installation only by certified SimonsVoss dealer, a service level agreement (SLA) must be concluded	LSM.DB
LSM DataBase Server, same functionality as LSM.DB for installation of GUI on up to four workplaces	LSM.DB-005
LSM DataBase Server, same functionality as LSM.DB for installation of GUI on up to nine workplaces	LSM.DB-010
LSM DataBase Server, same functionality as LSM.DB for installation of GUI on up to xx workplaces	LSM.DB-0xx

# LSM SERVICE LEVEL AGREEMENT (SLA)

An LSM Service Level Agreement (SLA) must be concluded from LSM BASIC with database module LSM.DB (LSM SLA STANDARD or LSM SLA PREMIUM).

Minimum term 24 months, automatic 12-month extension.  
Notice period: 3 months to the end of the agreement term.

## PRODUCT VERSIONS.

FOR LSM BASIC EDITION WITH DATABASE SERVER		FOR LSM BASIC EDITION WITH DATABASE SERVER	
LSM SLA STANDARD LSM SLA STANDARD provides you with telephone user support.		LSM SLA PREMIUM In addition to telephone user support, LSM SLA PREMIUM also provides you with online support and automatic LSM software upgrades.	
LSM DataBase Server	LSM.SLA.S.DB	LSM DataBase Server	LSM.SLA.P.DB
LSM DataBase Server 005	LSM.SLA.S.DB-005	LSM DataBase Server 005	LSM.SLA.P.DB-005
LSM DataBase Server 010	LSM.SLA.S.DB-010	LSM DataBase Server 010	LSM.SLA.P.DB-010
LSM DataBase Server 015	LSM.SLA.S.DB-015	LSM DataBase Server 015	LSM.SLA.P.DB-015
LSM DataBase Server 020	LSM.SLA.S.DB-020	LSM DataBase Server 020	LSM.SLA.P.DB-020
LSM DataBase Server 025	LSM.SLA.S.DB-025	LSM DataBase Server 025	LSM.SLA.P.DB-025
LSM DataBase Server 050	LSM.SLA.S.DB-050	LSM DataBase Server 050	LSM.SLA.P.DB-050
LSM DataBase Server 100	LSM.SLA.S.DB-100	LSM DataBase Server 100	LSM.SLA.P.DB-100
LSM Monitor	LSM.SLA.S.MONITOR	LSM Monitor	LSM.SLA.P.MONITOR
LSM Report	LSM.SLA.S.REPORT	LSM Report	LSM.SLA.P.REPORT
LSM Network 48	LSM.SLA.S.NW-48	LSM Network 48	LSM.SLA.P.NW-48
LSM Network 128	LSM.SLA.S.NW-128	LSM Network 128	LSM.SLA.P.NW-128
LSM VN Server	LSM.SLA.S.VN	LSM VN Server	LSM.SLA.P.VN
LSM Near Field Communication	LSM.SLA.S.NFC	LSM Near Field Communication	LSM.SLA.P.NFC
LSM Card	LSM.SLA.S.CARD	LSM Card	LSM.SLA.P.CARD

LSM  
SERVICE LEVEL AGREEMENT  
(SLA)

---

FOR LSM BUSINESS EDITION

---

LSM SLA STANDARD

LSM SLA STANDARD provides you with telephone user support.

LSM Business	LSM.SLA.S.BUSINESS
LSM Business 005	LSM.SLA.S.BUSINESS-005
LSM Business 010	LSM.SLA.S.BUSINESS-010
LSM Business 015	LSM.SLA.S.BUSINESS-015
LSM Business 020	LSM.SLA.S.BUSINESS-020
LSM Business 025	LSM.SLA.S.BUSINESS-025
LSM Business 050	LSM.SLA.S.BUSINESS-050
LSM Business 100	LSM.SLA.S.BUSINESS-100
LSM Card	LSM.SLA.S.CARD
LSM VN Server	LSM.SLA.S.VN
LSM Near Field Communication	LSM.SLA.S.NFC
LSM Network 48	LSM.SLA.S.NW-48
LSM Network 128	LSM.SLA.S.NW-128
LSM Network Enterprise	LSM.SLA.S.NW-ENTERPRISE
LSM Online	LSM.SLA.S.ONLINE
LSM Ressource Management	LSM.SLA.S.RM
LSM Multi DataBase	LSM.SLA.S.MULTIDB
LSM Terminal Server	LSM.SLA.S.TERMINAL
LSM CommNode 05 Clients	LSM.SLA.S.CN-05
LSM CommNode 10 Clients	LSM.SLA.S.CN-10
LSM CommNode Enterprise	LSM.SLA.S.CN-ENTERPRISE
LSM 03 Clients	LSM.SLA.S.CLIENT-03
LSM 05 Clients	LSM.SLA.S.CLIENT-05
LSM 10 Clients	LSM.SLA.S.CLIENT-10
LSM 25 Clients	LSM.SLA.S.CLIENT-25
LSM 50 Clients	LSM.SLA.S.CLIENT-50

---

FOR LSM BUSINESS EDITION

---

LSM SLA PREMIUM

In addition to telephone user support, LSM SLA PREMIUM also provides you with online support and automatic LSM software upgrades.

LSM Business	LSM.SLA.P.BUSINESS
LSM Business 005	LSM.SLA.P.BUSINESS-005
LSM Business 010	LSM.SLA.P.BUSINESS-010
LSM Business 015	LSM.SLA.P.BUSINESS-015
LSM Business 020	LSM.SLA.P.BUSINESS-020
LSM Business 025	LSM.SLA.P.BUSINESS-025
LSM Business 050	LSM.SLA.P.BUSINESS-050
LSM Business 100	LSM.SLA.P.BUSINESS-100
LSM Card	LSM.SLA.P.CARD
LSM VN Server	LSM.SLA.P.VN
LSM Near Field Communication	LSM.SLA.P.NFC
LSM Network 48	LSM.SLA.P.NW-48
LSM Network 128	LSM.SLA.P.NW-128
LSM Network Enterprise	LSM.SLA.P.NW-ENTERPRISE
LSM Online	LSM.SLA.P.ONLINE
LSM Ressource Management	LSM.SLA.P.RM
LSM Multi DataBase	LSM.SLA.P.MULTIDB
LSM Terminal Server	LSM.SLA.P.TERMINAL
LSM CommNode 05 Clients	LSM.SLA.P.CN-05
LSM CommNode 10 Clients	LSM.SLA.P.CN-10
LSM CommNode Enterprise	LSM.SLA.P.CN-ENTERPRISE
LSM 03 Clients	LSM.SLA.P.CLIENT-03
LSM 05 Clients	LSM.SLA.P.CLIENT-05
LSM 10 Clients	LSM.SLA.P.CLIENT-10
LSM 25 Clients	LSM.SLA.P.CLIENT-25
LSM 50 Clients	LSM.SLA.P.CLIENT-50

LSM  
SERVICE LEVEL AGREEMENT  
(SLA)

---

FOR LSM PROFESSIONAL EDITION

---

LSM SLA STANDARD

LSM SLA STANDARD provides you with telephone user support.

LSM Professional	LSM.SLA.S.PROFESSIONAL
LSM Professional 005	LSM.SLA.S.PROFESSIONAL-005
LSM Professional 010	LSM.SLA.S.PROFESSIONAL-010
LSM Professional 015	LSM.SLA.S.PROFESSIONAL-015
LSM Professional 020	LSM.SLA.S.PROFESSIONAL-020
LSM Professional 025	LSM.SLA.S.PROFESSIONAL-025
LSM Professional 050	LSM.SLA.S.PROFESSIONAL-050
LSM Professional 100	LSM.SLA.S.PROFESSIONAL-100
LSM Card	LSM.SLA.S.CARD
LSM VN Server	LSM.SLA.S.VN
LSM Near Field Communication	LSM.SLA.S.NFC
LSM Network 48	LSM.SLA.S.NW-48
LSM Network 128	LSM.SLA.S.NW-128
LSM Network Enterprise	LSM.SLA.S.NW-ENTERPRISE
LSM Online	LSM.SLA.S.ONLINE
LSM Ressource Management	LSM.SLA.S.RM
LSM CommNode 05 Clients	LSM.SLA.S.CN-05
LSM CommNode 10 Clients	LSM.SLA.S.CN-10
LSM CommNode Enterprise	LSM.SLA.S.CN-ENTERPRISE
LSM 03 Clients	LSM.SLA.S.CLIENT-03
LSM 05 Clients	LSM.SLA.S.CLIENT-05
LSM 10 Clients	LSM.SLA.S.CLIENT-10
LSM 25 Clients	LSM.SLA.S.CLIENT-25
LSM 50 Clients	LSM.SLA.S.CLIENT-50

---

FOR LSM PROFESSIONAL EDITION

---

LSM SLA PREMIUM

In addition to telephone user support, LSM SLA PREMIUM also provides you with online support and automatic LSM software upgrades.

LSM Professional	LSM.SLA.P.PROFESSIONAL
LSM Professional 005	LSM.SLA.P.PROFESSIONAL-005
LSM Professional 010	LSM.SLA.P.PROFESSIONAL-010
LSM Professional 015	LSM.SLA.P.PROFESSIONAL-015
LSM Professional 020	LSM.SLA.P.PROFESSIONAL-020
LSM Professional 025	LSM.SLA.P.PROFESSIONAL-025
LSM Professional 050	LSM.SLA.P.PROFESSIONAL-050
LSM Professional 100	LSM.SLA.P.PROFESSIONAL-100
LSM Card	LSM.SLA.P.CARD
LSM VN Server	LSM.SLA.P.VN
LSM Near Field Communication	LSM.SLA.P.NFC
LSM Network 48	LSM.SLA.P.NW-48
LSM Network 128	LSM.SLA.P.NW-128
LSM Network Enterprise	LSM.SLA.P.NW-ENTERPRISE
LSM Online	LSM.SLA.P.ONLINE
LSM Ressource Management	LSM.SLA.P.RM
LSM CommNode 05 Clients	LSM.SLA.P.CN-05
LSM CommNode 10 Clients	LSM.SLA.P.CN-10
LSM CommNode Enterprise	LSM.SLA.P.CN-ENTERPRISE
LSM 03 Clients	LSM.SLA.P.CLIENT-03
LSM 05 Clients	LSM.SLA.P.CLIENT-05
LSM 10 Clients	LSM.SLA.P.CLIENT-10
LSM 25 Clients	LSM.SLA.P.CLIENT-25
LSM 50 Clients	LSM.SLA.P.CLIENT-50

# LSM SYSTEM REQUIREMENTS

## GENERAL.

- ⌘ Local administrator rights for installation
- ⌘ Communication: TCP/IP (NetBios active), LAN (recommended: 100 Mbps)
- ⌘ Windows Domain
- ⌘ Name resolution
- ⌘ NET Framework 2.0 min., 3.5 recommended
- ⌘ MS ActiveSync 4.2 in combination with a PocketPC
- ⌘ RS-232 and/or USB interface

## CLIENT.

(LSM BASIC, LSM BUSINESS, LSM PROFESSIONAL)

### Minimum hardware requirements

- ⌘ Monitor min. 19" (48 cm) (or larger for matrix view display)
- ⌘ Minimum screen resolution: 1024 x 768, recommended: 1280 x 1024
- ⌘ Processor: at least 2.66 GHz (or faster)
- ⌘ At least 2 GB RAM (or more)
- ⌘ Hard disk capacity approx. 500 MB (approx. 1 GB during installation), database depends on the volume of data to be processed (approx. 30 MB)
- ⌘ MS Windows XP Prof. SP3
- ⌘ MS Windows Vista (Business, Enterprise, Ultimate), 32 or 64 bit
- ⌘ MS Windows 7 (Professional, Enterprise, Ultimate), 32 or 64 bit

## SERVER.

(DATABASE SERVER FROM LSM BUSINESS EDITION)

### Minimum hardware requirements

- ⌘ Processor: at least 2.66 GHz (or faster)
- ⌘ At least 2 GB RAM (or more)
- ⌘ Hard disk capacity application approx. 300 MB (approx. 500 MB during installation), database depends on the volume of data to be processed (approx. 30 MB)
- ⌘ MS Windows Server 2003
- ⌘ MS Windows Server 2008
- ⌘ MS Windows Server 2008 R2
- ⌘ .NET Framework when using the CommNode Server at least 3.5
- ⌘ Server-based application: a share on the ADS server is required for the database directory

© Copyright 2012, SimonsVoss Technologies AG, Unterfoehring  
All rights reserved. Text, photos and graphics are subject to  
copyright protection. The content of this brochure must not be  
copied, disseminated or modified. Please refer to our systems  
manual for exact technical specifications. Technical details  
subject to change.

SIMONSSVOSS TECHNOLOGIES AG

Feringastrasse 4  
85774 Unterfoehring  
Germany  
Tel. +49 89 99228-0  
Fax +49 89 99228-222  
info@simons-voss.com  
www.simons-voss.com